



PASHU SAKHI MODULE

TABLE OF CONTENTS

1. Why do we keep animals?	7
2. What animals are kept in your community?	7
3. What are the animals used for?	7
4. How good are your animals?	7
5. Animals and the environment	9
6. Organs and systems of the body	12
7. Body temperature.....	17
8. Appearance of the healthy animal.....	20
9. Spread of disease.....	24
10. Breeds in India	26
11. What is Animal Breeding?.....	40
12. Ruminants	42
13. How to age sheep, goats, cattle and buffalo.....	44
14. Restraining cattle and buffalo	48
15. Foot (hoof) care.....	51
16. Sheep and goat housing.....	53
17. NUTRITION AND MANAGEMENT OF SHEEP AND GOATS	55
18. Shearing and dagging (crutching).....	66
19. Dehorning calves, lambs and kids.....	68
20. Castration of ruminants.....	70
21. Internal parasites of ruminants.....	74
22. External parasites of ruminants.....	77
23. Signs of heat (oestrus) in ruminants.....	80
24. Pregnancy in ruminants.....	84
25. Calving (parturition)	86
26. Lambing and kidding (parturition).....	89
27. Care of the newborn.....	91
28. Milk production and the udder.....	94
29. ECONOMIC CHARACTER IN DAIRY CATTLE.....	96
30. HOUSING FOR DAIRY CATTLE.....	99
31. ARTIFICIAL INSEMINATION	110
32. Infection of the udder (mastitis).....	120
33. Feed and water for ruminants.....	123

34. Grazing management	127
35. Common Animal Diseases and their Prevention and Treatments.....	137
36. Community Question & Answer.....	185
37. Handling and restraining pigs	192
38. Keeping chickens and ducks	210
39. First Aid in animals.....	239
40. Health of the community.....	269
41. Selection of animals for breeding	285
42. Record keeping	288
43. What the trainer must do.....	291
44. The conditions of learning	292
45. Evaluating the trainee's progress.....	294
46. Ethnoveterinary Practices	297
i Herbal masala bolus for all Digestive Problems.....	297
ii Tympany:	298
iii Diarrhea:	298
iv Constipation:	299
v Endoparasites (Intestinal worms).....	299
vi Ectoparasites (Lice, ticks, mites)	300
vii Respiratory tract Infections:.....	301
viii Foot and Mouth Disease	301
ix Mastitis in Dairy animals	302
x Infertility	303
xi Retention of Placenta:	303
xii Prolapse of the Uterus.....	304
xiii Blue Tongue Disease in Sheep and Goats.....	304
xiv Poisonous bite or Food poisoning:.....	305
xv Eye Injuries	306
xvi Wounds	306
xvii Panchagavya for Animal Health	306
xviii Milk fever or Calcium Deficiency:	307
xix Poultry Diseases.....	307
a. For Ranikhet disease:.....	307
b. For Lice Infestation of Poultry :.....	308

Table of Figures

Figure 1: Livestock's & People	8
Figure 2: Sheep (English - Somali).....	9
Figure 3: Cows (Friesan - Sahiwal)	10
Figure 4: THE RESPIRATORY SYSTEM	14
Figure 5: NERVOUS SYSTEM	14
Figure 6: Reproductive and urinary organs of the male.....	15
Figure 7: Female reproductive and urinary system.....	15
Figure 8: thermometer	18
Figure 9: How to take the body temperature of animals.....	19
Figure 10: NOSE AND MUZZLE	21
Figure 11: The coat.....	21
Figure 12: RUMEN MOVEMENT	43
Figure 13: How to hold sheep and goat to check their teeth.....	44
Figure 14: How to hold cattle and buffalo to check their teeth.....	44
Figure 15: AGE OF GOATS AND SHEEP	45
Figure 16: AGE OF CATTLE	46
Figure 17: AGE OF BUFFALO	47
Figure 18: HOW TO HOLD ANIMALS (Nose holder).....	48
Figure 19: HALTERING LARGE RUMINANTS (CATTLE AND BUFFALO).....	49
Figure 20: CASTING OR THROWING CATTLE AND BUFFALO	50
Figure 21: how to hold to trim feet's	51
Figure 22: leg may be lifted and tied	52
Figure 23: sharp tool for trimming feet	52
Figure 24: male reproductive sysytem.....	62
Figure 25: Scrotum types.....	62
Figure 26: DAGGING	67
Figure 27: THE TOOLS USED TO DISBUD ANIMALS.....	68
Figure 28: HOLDING AND CONTROLLING ANIMALS FOR CASTRATION.....	71
Figure 29: CASTRATION WITH BURDIZZO (NO BLOOD)	72
Figure 30: CASTRATION WITH RUBBER RINGS	73
Figure 31: types of PARASITES.....	74
Figure 32: HOW DO ANIMALS BECOME INFECTED WITH PARASITES?	75
Figure 33: Mites	77
Figure 34: Lice	77
Figure 35: RINGWORM.....	78
Figure 36: Signs of heat in free animals (at pasture)	81
Figure 37: NORMAL CALVING.....	86
Figure 38: DIFFICULTIES IN CALVING	87
Figure 39: STAR GAZING	89
Figure 40: WHEN AND HOW TO HELP IN PARTURITION.....	90
Figure 41: HAND REARING ORPHANS	93
Figure 42: HOW MILK IS MADE.....	94
Figure 43: Cattle Shed	102
Figure 44: Shed for calves	102
Figure 45: Tail to Tail System	103
Figure 46: Face to face system	104
Figure 47: Semen Collection	113
Figure 48: RECTO VAGINAL METHOD.....	114
Figure 49: INFECTION OF THE UDDER (MASTITIS)	120

Figure 50: FODDER CHAFFING & Fodder storage -hay	122
Figure 51: silage making	122
Figure 52: SILO.....	125
Figure 53: PASTURE ROTATION.....	128
Figure 54: Chaffed fodder Filling and pressing in silo pit Fully sealed silo pit.....	130
Figure 55: Sun drying of green foliage Bundles of hay	131
Figure 56: WHAT TO DO WITH A BITING DOG	143
Figure 57: Management factors in piglets	170
Figure 58: Susceptible species and transmission	171
Figure 59: HANDLING THE YOUNG PIG	192
Figure 60: CLIPPING THE TEETH	194
Figure 61: SIGNS OF HEAT in pigs.....	198
Figure 62: Castration cuts in pigs	202
Figure 63: HOUSING AND PENS FOR PIGS	206
Figure 64: HOUSING FOR PIGLETS	207
Figure 65: HOUSING FOR PIGLETS (B).....	208
Figure 66: Notching the ear	209
Figure 67: RECORDING THE NUMBER OF THE PIG.....	209
Figure 68: THE FERTILITY OF THE EGG	211
Figure 69:THE QUALITY OF EGGS	212
Figure 70: RUNS FOR BIRDS (FENCED AREAS)	214
Figure 71: Housing for ducks	214
Figure 72: DIGESTIVE SYSTEM OF THE BIRD	215
Figure 73: PROBLEMS CAUSED BY A LACK OF VITAMINS	219
Figure 74: CANDLING (CHECKING THE EGGS).....	221
Figure 75: quality testing of an egg	221
Figure 76: BROODER (FOR KEEPING VERY YOUNG BIRDS)	222
Figure 77: WATER TROUGHS (CONTAINERS).....	222
Figure 78: FEED TROUGHS (CONTAINERS)	223
Figure 79: THE BROODY HEN.....	224
Figure 80: Oil barrel - charcoal	226
Figure 81: Kerosene brooder	227
Figure 82: Storm lantern brooder.....	227
Figure 83: Housing for hot - arid climates.....	229
Figure 84: Open house type.....	229
Figure 85: Moveable type housing	230
Figure 86: lighting schedule for birds.....	231
Figure 87: COCCIDIA IN CHICKENS AND DUCKS	234
Figure 88: FLEAS, MITES AND LICE INFECTING CHICKENS AND DUCKS	236
Figure 89: The infections of chickens and ducks.....	237
Figure 90: Bleeding from a broken horn	259
Figure 91: Dislocation of bones.....	262
Figure 92: Abscesses in the lymph nodes (glands)	263
Figure 93: COMMUNITY'S WATER SUPPLY AND ANIMALS	270
Figure 94: Non-slip knots	282
Figure 95: Safety knot	282
Figure 96: Double loop.....	283
Figure 97: Tying two ropes together	283
Figure 98: Rolling hitch.....	284
Figure 99: Badly shaped jaws.....	286

List of tables

Table 1: Normal body temperatures19
Table 2: TEMPORARY (MILK) AND PERMANENT TEETH44
Table 3 :Recommended Floor and Trough Space for Sheep/ Goats in intensive Production Related to Live Weight 54
Table 4: LENGTH OF PREGNANCY84
Table 5: A PRACTICAL RECOMMENDATION FOR TIMING OF INSEMINATION119
Table 6: Daily ration for animals124
Table 7: FEEDING SCHEDULE Calf feeding schedule (birth to 26th of week of age)135
Table 8: ration for birds217
Table 9: Types of poultry enterprises225
Table 10: Temperature and its effects on egg production.....232

ACKNOWLEDGEMENT

The pleasure that follows the successful completion of an assignment would remain incomplete without a word of gratitude for the people and without whose cooperation the achievement would remain a distant dream. It is not a mere formality to place a record the tireless efforts, ceaseless cooperation, constant guidance and encouragement of the people closely associated with the assignment but a distinct necessity for the authenticity and readability of the assignment.

I am thank-full to, Dr. Jaywerdhan Tiwari, Mr. S.B. Nadegowda, Dr. Parikhita Kundu, Mr. Parumal Vivekanand, Dr. Anil K. Pegu Dr. Birendra Prasad Yadav, Dr. Dharmeshwar Das, Mr. Vikas Kunj Mr. Vivek Kunj and Mr. Sundeep Singh (collating the whole document) for his/her scholarly support, advice and encouragement and also FAO & NDDDB websites for providing necessary information to develop Pashu Sakhi module in prescribed period.

1. WHY DO WE KEEP ANIMALS?

we keep animals to provide us with: meat, milk, eggs, wool and hair for clothing, ropes and tents hides and skin for leather bones, hooves and horn for a variety of uses. Some animals are used for transport, ploughing and work. We always benefit from the animals we keep.

Learning objectives

After studying this unit, you should:

1. Know what animals are kept in your community.
2. Know what the animals are used for.
3. Find out if the animals in your community or village are good and healthy.

2. WHAT ANIMALS ARE KEPT IN YOUR COMMUNITY?

If you want to be a good Pashu Sakhi it is very important for you to know what animals are kept by the people in your community. You must know your community very well and discover who keeps animals and what type of animals they keep. You must work with all of the community's livestock.

3. WHAT ARE THE ANIMALS USED FOR?

What does your community keep its animals for? Are the animals kept for meat or for work? Do they provide you with milk? What other things do you get from the livestock you keep? If you keep animals for meat do you kill the young or the old animal for meat? Does your community keep some animals only for work or for meat, to give milk, or for other reasons? Try to find out as much as you can about the use of animals in your community.

4. HOW GOOD ARE YOUR ANIMALS?

Are your animals providing you with enough milk or meat? Are your livestock better than those of neighboring communities or regions? How do your animals differ from those in neighboring communities? Communities in neighboring regions can keep different types of animals. For example, cows in one region can produce more milk or give better meat than those in another region. You should consider your livestock and compare them to those of your neighboring communities. Talk to people from other communities or to other Primary Animal Health Care Workers.

You may already know of some health problems in your community's livestock. If you talk to others in the community, you may find out about other animal health problems. There may be particular problems related to certain breeds or types and not others. Some of the health problems you may discover are:

- Animals die suddenly.
- Young animals are born sick or dead.
- Leg and foot problems.
- Skin troubles.
- Animals do not increase in weight.
- Livestock suffer from worms, ticks or lice.
- The udders of milk animals become swollen and blood is found in the milk.
- Chickens stop laying eggs or die suddenly.

There can be very many health problems. You should talk to the people in your community to discover the various problems they have with the health of their animals, but also try to discover the problems in neighboring communities. You may find that you have the same problems or you will gain knowledge which will help you prevent a health problem reaching your community's livestock.

You must keep good contacts with your nearest veterinarian and livestock specialist. Remember that these people are there to help you. Keep an animal health record for your community. It will help you to succeed as a Pashu Sakhi if you keep a record of the health and other problems of your community's livestock.

Make a record of who keeps the various animals. Discover and make note of the problems that they have. Talk to the owner of the animals and discover if the problems are related to a particular time of the year or season, changes in food or water supply, movement of livestock or the introduction of new animals to the herd. Keep an animal health record for your community.

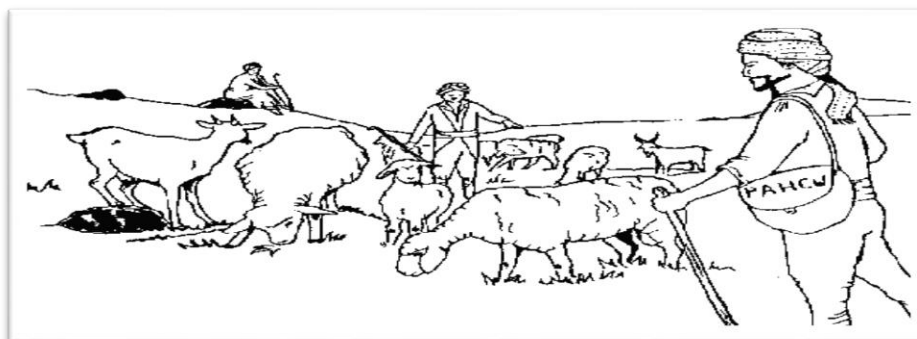

FIGURE 1: LIVESTOCK'S & PEOPLE

5. ANIMALS AND THE ENVIRONMENT

The environment is what you find around you. The plants, water, soil and climate are all part of your environment. Man, keeps animals which are suited to his needs and his environment. There is a limit to the number of animals which we can keep in any area. If we ignore these facts, we can have management and health problems in our livestock and damage to the local environment.

Learning objectives

After studying this unit, you should know:

1. The problems which can result from keeping too many animals.
2. If the animals, you keep are suited to your environment and your needs.
3. The different breeds (types) of animals kept in your community.
4. Any areas of the community's land which have been damaged by animals.

DIFFERENT BREEDS (TYPES) OF ANIMAL

Throughout the world man keeps animals which are suited to the local environment. Feed, water and climate are the main factors which determine what animals are in any one region. As a result of this we find a large variety of animal breeds throughout the world.

- In England sheep have thick woolly fleeces to protect them against cold winters. In Somalia, where the climate is very hot, the sheep have light, hairy coats

Sheep (English - Somali)

- Friesian cows produce a lot of milk on the good grasslands in countries with cool weather conditions. In India, the Sahiwal cattle are good milk producers in the hot tropics.

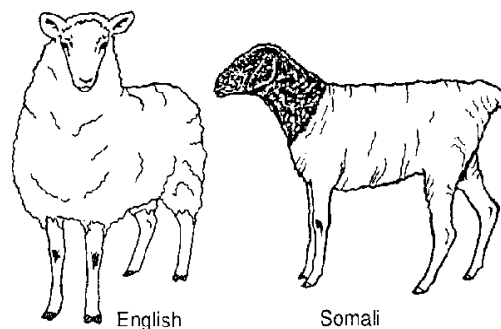
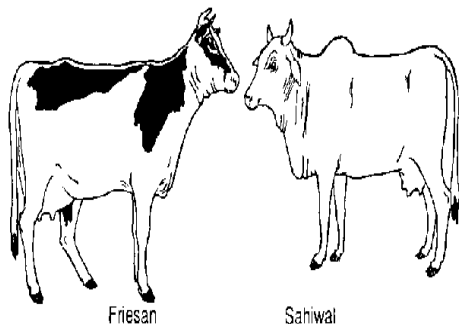

FIGURE 2: SHEEP (ENGLISH - SOMALI)

Cows (Friesan - Sahiwal)



- In China pigs are fed on food which is mainly roughage and so developed a pot-belly to use this type of food. In Europe pigs are fed a lot of grain and have leaner bodies.

FIGURE 3: COWS (FRIESAN - SAHIWAL)

Chinese pot belly pig - European pig

Remember that the livestock in your community developed over a long time. They are accustomed to your environment. Sometimes people want to introduce new breeds to an area. This must be carefully considered and advice taken from knowledgeable persons as the new breeds may not be suited to the new environment.

The number of animals kept in the community We should not keep animals which are old or barren as they will eat the feed that could be better used for young animals.

You should consider the number of animals kept in your community. Is enough feed and water available for them all year? Discuss with your community elders and leaders any problems you may discover in the numbers of animals and the available feed and water. Controlling and planning livestock numbers and the availability of good feed and water is basic to primary animal health care.

Problems of overstocking (too many animals)

If we do not keep the numbers of livestock in relation to available feed and water, then:

1. Animals lose weight, become sick and disease spreads.
2. Animals do not breed well and death of young occurs.
3. Overgrazing and loss of pasture, bushes and trees occur.
4. Loss of vegetation will result in erosion of soil and loss of good land.

Talk to the elders in your community and discover what changes there have been in the environment and what may have caused them. Can the situation be improved?

The body is made up of many, many millions of cells which you cannot see unless you use a microscope. Special cells come together to make an organ. An organ is a complex structure within the body. It has a special job or jobs to do. A body system consists of a number of organs which work together to carry out a special job. The animal body is made of 9 systems:

1. Musculo-skeletal system.
2. Digestive system
3. Circulatory system
4. Respiratory system
5. Urinary system
6. Nervous system
7. Sensory system
8. Reproductive system
9. Lympho-reticular system

6. ORGANS AND SYSTEMS OF THE BODY

Learning objectives

After studying this unit you should know:

1. The various organs of the body.
2. The position of the main organs within the body.
3. The structure of the body systems.
4. How the systems work.

THE ORGANS OF THE BODY

An organ is a complex structure with a special job or a number of jobs to do. For example:

1. The eye is the organ of sight.
2. The kidneys are organs which get rid of water and poisonous materials from the body as urine.
3. The liver has many jobs and is involved in more than one system.

Various organs are grouped together to form a body system which carries out a special job.

System of the Body	Organs in the Body	Job or function
Musculo-skeletal	muscle (meat) bones	Support and move the body
Digestive	stomach, liver, intestine, pancreas	Digest and absorb feed
Circulatory	heart, blood vessels	The blood carries substances around the body
Respiratory	muzzle, windpipe, lungs	Breathing
Urinary	kidneys, bladder	Get rid of poisons and waste (urine)
Nervous	brain, nerves spinal cord	Pass messages around the body, control the body
Sensory	eyes, ears, nose skin	Sense and detect things outside the body
Reproductive	testes, penis ovaries, uterus, vagina, vulva, udder	To produce and feed young

Lympho-reticular	lymph nodes, spleen	Protect against infectious diseases, produce blood
-------------------------	---------------------	----------------------------------------------------

THE MUSCULO-SKELETAL SYSTEM

This system consists of the bones and the muscles (meat). The bones form the skeleton which is the framework within the body. It carries weight and supports the body.

Bones are connected together so they can move. The places where this happens are called joints. The bones are held together at the joints by elastic strands called ligaments. Between the bones is a softer material called cartilage (gristle) which cushions the bones at the joints when the body moves. Bones are very hard and contain minerals. Each bone has a name such as the scapula (shoulder blade) and skull (head). There are about 200 bones in the body.

Muscles are joined at both ends to the bones. The muscles are the meat of the body and when they contract (shorten) or relax (lengthen) they make the bones move.

If you bend your arm you can see and feel the muscles in your arm working.

THE DIGESTIVE SYSTEM

The digestive system consists of the teeth, mouth, gullet (esophagus), stomach, liver, intestine, pancreas, and rectum. Digestion begins in the mouth where feed is broken down into small pieces by the teeth and mixed with saliva before being swallowed. In the stomach feed is mixed with the juices to form a soft paste. This then passes into the intestine where bile from the liver and juices from the pancreas are added. The action of these juices is to break down the feed and allow the nourishment it contains to be absorbed by the blood in the walls of the intestine. Waste matter collects in the rectum and passes out of the body through the anus (or cloaca in birds).

THE CIRCULATORY SYSTEM AND BLOOD

The organs of the circulatory system are the heart and the blood vessels (tubes). The heart is found in the chest cavity. It is a muscular pump which sends blood around the body. The blood vessels which carry blood away from the heart are called arteries. Blood returns to the heart in veins. Joining the arteries and veins is a fine network of small tubes called capillaries. The capillaries pass through every part of the body. When the heart beats its muscles contract and sends blood out through the arteries. When the heart relaxes blood flows into it from the veins. Every time the heart beats it sends a pulse

along the arteries. You can feel it at certain points on the body. By feeling the pulse we can count the rate at which the heart beats. You can feel your pulse on your wrist.

THE RESPIRATORY SYSTEM

Respiration (breathing) consists of inspiration (breathing in) and expiration (breathing out). There are two lungs which are found in the chest protected by the bony cage of the ribs. The windpipe carries air from the nostrils to the lungs which are spongy because of air spaces in them. As the animal breathes, air moves in and out of the lungs. Inside the lungs oxygen needed by the body passes into the blood in the walls of the lungs and water and carbon dioxide pass out of the blood into the air which is then breathed out.

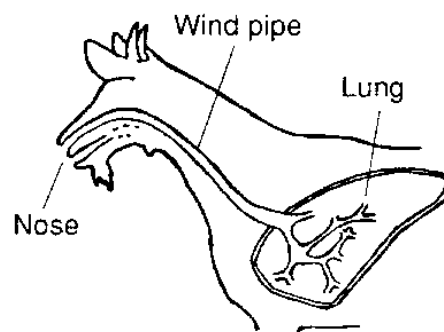

FIGURE 4: THE RESPIRATORY SYSTEM

THE URINARY SYSTEM

The main organs are the two kidneys, which lie against the backbone, and the bladder.

Waste materials and water are taken out of the blood in the kidneys. This forms urine. Urine collects in the bladder then passes out of the body.

The bones of the skull and backbone protect the soft brain and spinal cord. Fibres called nerves pass from the brain and spinal cord to all parts of the

Messages pass from the various parts of the body along the nerves to the brain. The brain sends a message back telling the different parts of the body what to do.

The brain controls the body.

NERVOUS SYSTEM

The brain also controls the senses; the sense organs are:

1. The eyes for sight
2. The ears for hearing
3. The nose for smell
4. The tongue for taste
5. The skin for touch

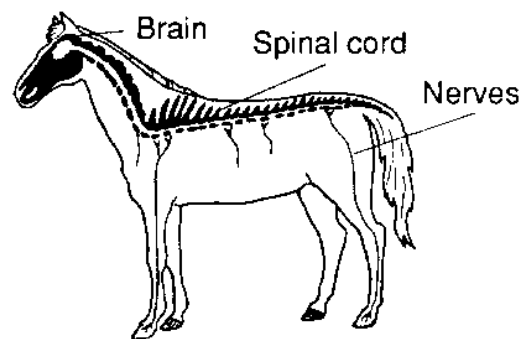

FIGURE 5: NERVOUS SYSTEM

REPRODUCTIVE SYSTEM (BREEDING)

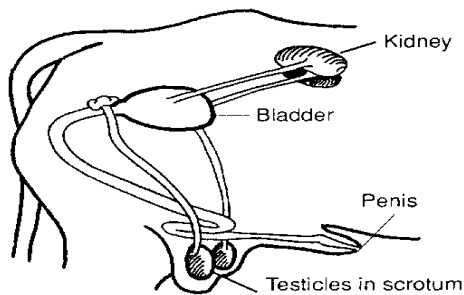

FIGURE 6: REPRODUCTIVE AND URINARY ORGANS OF THE MALE

The male reproductive organs, the testicles, lie in the scrotum behind the penis. The testicles produce sperm which are contained in the fluid semen. A tube passes from each testicle and joins to form a tube which runs down the centre of the penis.

In the bird the testicles are inside the body.

The female reproductive organ consists of two ovaries, one in each side of the lower abdomen. The ovaries produce eggs which pass into the uterus (or womb). Below the uterus is the vagina which opens to the outside surrounded by the vulva. After birth the young are fed on milk produced by the udder.

During mating (mounting) sperm passes from the male into the uterus and joins with the eggs there. When the sperm joins the egg, it forms the embryo which develops into the young animal inside the uterus.

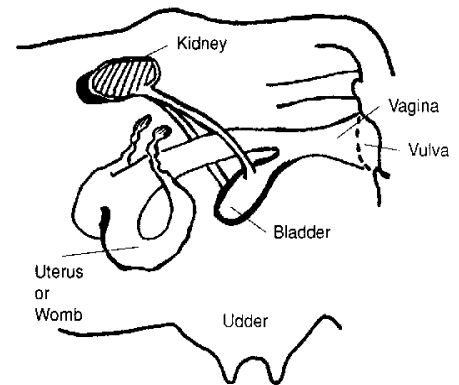

FIGURE 7: FEMALE REPRODUCTIVE AND URINARY SYSTEM

Reproduction is controlled by hormones (chemical messengers) which are carried in the blood to the different organs.

These hormones control:

1. Puberty of the animal
2. Production of eggs
3. Birth
4. Production of semen
5. Development of the embryo
6. Milk production

LYMPHO-RETICULAR SYSTEM

Lymph is a colorless fluid which passes out of the blood into a network of fine tubes called the lymphatic system. It passes through the lymph nodes, where germs are filtered out and killed, before it is returned to the veins. The lymph nodes and spleen also produce special blood cells which protect the body against disease. Sometimes when an animal is infected the lymph nodes become swollen and can be felt beneath the skin.

7. BODY TEMPERATURE

The body must be kept at a constant temperature, within a small range, in order for all of the systems to work properly. This is the normal body temperature.

A change in the temperature of the body is a sign of ill health.

Learning objectives

After studying this unit you should understand what is meant by:

1. The normal body temperature.
2. High body temperature.
3. Low body temperature.
4. How to take the body temperature.
5. What is the normal body temperature of different animals.

The normal body temperature

The body can only work properly at a certain temperature. The animal body maintains itself at a constant temperature, within a small range, in order for the systems to work properly. This normal body temperature is different in different types of animals. There are a number of ways by which animals control the temperature of the body:

- Hair, wool, walking, running, shivering and the burning of energy in feed keep the body warm.
- Sweating, panting, wallowing in mud, and lying in the shade cool the body.

Measuring body temperature

We use a thermometer to measure the temperature of the body. The unit of measurement is degrees centigrade (°C). The normal temperature of your body is 37°C. We measure the body temperature of animals by placing a thermometer in the anus.

Thermometer

- Look at your thermometer. Notice the silver line of the mercury inside it and the scale with numbers marked along it.

- Before you use it you must make sure that the mercury level is below 35°C. If it is not, shake the thermometer to make the level go down.
- Every time you use the thermometer clean it with cold water and soap or disinfect it afterwards.

Do not wash the thermometer in hot water as this will burst it. Do not leave your thermometer in the sun as this may burst it. Carry the thermometer in a case in your pocket or bag. Do not use your veterinary thermometer for people.

Thermometer

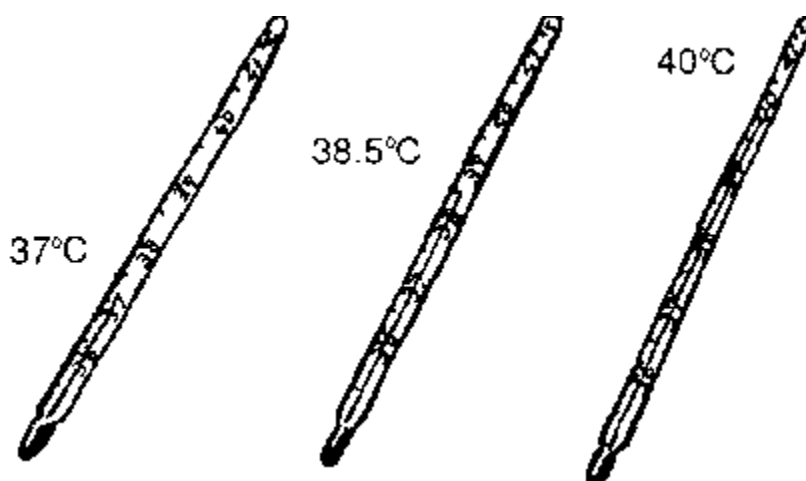
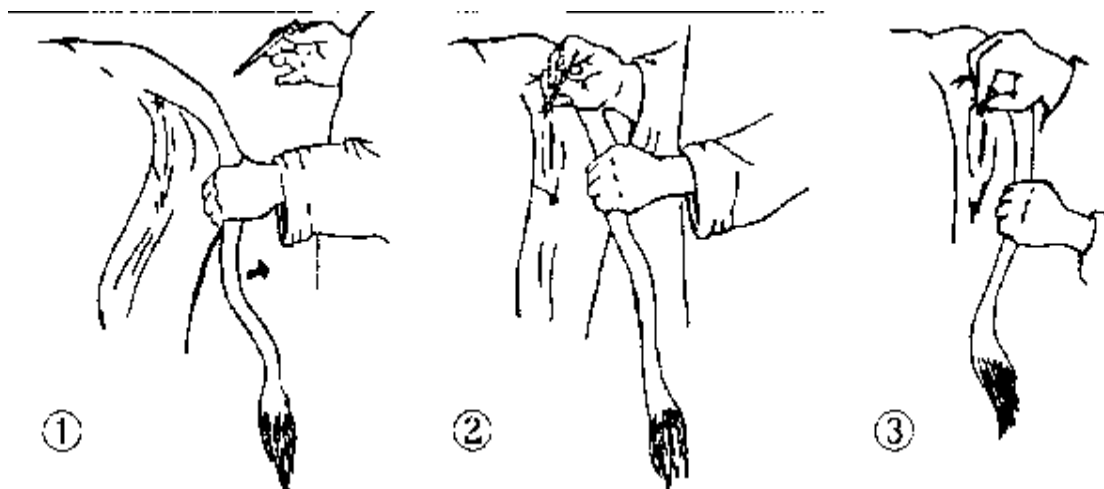

FIGURE 8: THERMOMETER

How to take the body temperature of animals

- Control the animal.
- Move the tail to the side.
- Put the thermometer gently into the anus, as far as possible.
- Hold the thermometer at an angle so that it touches the wall of the rectum. Keep a firm grip on the thermometer, if the animal defecates or coughs the thermometer could come out or go into the rectum.
- Hold the thermometer in place for half a minute. If you do not have a watch count slowly up to 30 (one, two, three, thirty).
- Remove the thermometer and wipe it if necessary and read it. Do not touch the bulb as this could change the reading.

How to take the body temperature of animals

**FIGURE 9: HOW TO TAKE THE BODY TEMPERATURE OF ANIMALS**

Normal body temperatures

Animal	Normal Temperature °C	Normal Animal	Temperature °C
Cattle	38.5	Calf	39.5
Buffalo	38.2	Goat	39.5
Sheep	39.0	Camel*	34.5-41.0
Llama, alpaca	38.0	Horse	38.0
Donkey	38.2	Pig	39.0
Chicken	42.0	Piglet	39.8

TABLE 1: NORMAL BODY TEMPERATURES

Body temperatures may be 1°C above or below these temperatures.

* The camel's body temperature will vary with the time of day and water availability. When a camel is watered daily its body temperature rises from 36.5°C in the morning to 39.5°C at noon, if the animal has no water, the temperature range is 34.5°C to 41°C.

If you suspect that the animal has a high temperature use your thermometer to check it. Remember that a high temperature is one sign of ill health. When an animal has a high temperature, it has a fever.

8. APPEARANCE OF THE HEALTHY ANIMAL

You should be able to distinguish between the sick and the healthy animal. Identifying the signs of ill health in livestock will mean that you can:

1. Give first aid and treat ill animals quickly
2. Prevent the spread of disease to other animals
3. Recognize any problems in animals offered for sale
4. Recognize any signs of health problems in animals to be used for breeding

Learning objectives

After studying this unit you should know:

1. The characteristics of the healthy animal.
2. Recognize the signs of ill health.

APPEARANCE OF THE ANIMAL

The healthy animal is alert and aware of its surroundings. It is active and holds its head up watching what is happening around it. It should stand on all of its feet. The separation of an animal from the others in its group is often a sign of a health problem.

An animal which is not interested in its surroundings and does not want to move has health problems.

MOVEMENT (GAIT)

The healthy animal will walk easily and steadily with all of its feet taking its weight. Steps should be regular. Irregular movement results from pain in the feet or limbs.

Horses normally stand during the day. If you go near an animal that is lying down it should stand up quickly otherwise it has health problems.

EYES

The eyes should be bright and alert with no discharge at the corners.

EARS

Most animals have erect ears which move in the direction of any sound. Ear movements will also be quick to get rid of flies, the body temperature of the pig can be checked by touching the ear when an unusually high temperature will be noticed.

NOSE AND MUZZLE

The nose should be clean with no discharge. In cattle and buffalo the muzzle should be moist not dry. In sheep and goats, the nose should be cool and dry. Healthy animals frequently lick their noses with their tongues.

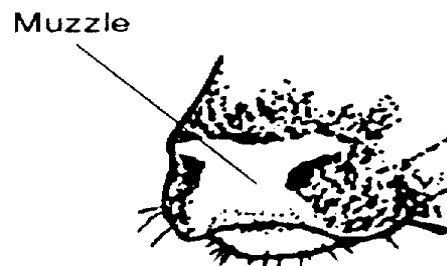

FIGURE 10: NOSE AND MUZZLE

MOUTH

There should be no saliva dripping from the mouth. If chewing is slow or incomplete there must be a problem with the teeth.

THE COAT

In short-haired animals, e.g. goat and cattle, the hair or coat of the healthy animal will be smooth and shiny. Healthy cattle, buffalo and their calves lick their coat and the lick marks will show. Horses should not sweat when resting.



FIGURE 11: THE COAT

In poultry, the feathers should be smooth and glossy and not ruffled. In pigs a curly tail is a sign of good health while a scaly skin points to health problems.

BEHAVIOUR

If a horse, cow or buffalo keeps looking at its flanks or kicks at its belly it has a pain in the stomach.

BREATHING

Breathing should be smooth and regular at rest. Remember that movement and hot weather will increase the rate of breathing. If the animal is resting in the shade it should be difficult to notice the chest moving as it breathes.

PULSE

Taking the pulse is important when examining an animal. In man the pulse can be easily taken but in animals it is more difficult and requires practice.

1. In sheep and goats, you can feel the pulse on the inside of the top of the back leg. The rate of the pulse is 70 - 130 per minute in the adult.
2. The pulse of cattle is taken at a point on the underside of the base of the tail, the normal rate is 40 - 80 per minute in the adult. In buffalo the pulse rate is 40 - 60 per minute.
3. The pulse of the horse is taken on the inside of the cheek. The normal rate is 35 - 40 per minute.
4. The pulse of the camel is taken at a point on the underside of the root of the tail. The normal rate is 35 - 45 beats per minute.

Remember that the pulse will be higher in the young animal. To take the pulse you should feel for it with the first two fingers of the hand.

In the llama, alpaca and the pig there is no point at which the pulse can be taken. In these animals, the beat of the heart itself must be felt for.

DROPPINGS OR DUNG

The droppings of the healthy animal will be firm. Very soft droppings (diarrhea) is a sign of ill health. If the animal has difficulty in defecating (constipation) this is also a bad health sign.

URINE

The urine should be clear and the animal show no signs of pain or difficulty in urinating. Horses, mules and donkeys can have thick yellow urine which is normal.

APPETITE AND RUMINATION

The animal should eat and drink normally. Failure to eat is an obvious sign of ill health. If feed is available, the healthy animal will have a full belly. Pigs will naturally rush at their feed, if they do not something is wrong. Sheep, goats, cattle, buffalo and camels chew the cud (ruminate) for 6 to 8 hours each day. It is a sign of ill health when these animals stop ruminating.

MILK

In the milking animal, a sudden change in the amount of milk produced can mean a health problem. Any sign of blood or other matter in the milk points to infection in the udder. There should be no swelling of the udder and no sign of pain when it is touched. There should be no injury to the teat.

BODY TEMPERATURE

If you suspect that an animal is sick you should take its temperature. Taking the temperature may show a higher than normal body temperature which is sign of an infection.

A good Pashu Sakhi learns to:

1. Carefully watch the normal animal at all times and learn how it behaves.
2. You will then recognize when something is not right.
3. Question the person looking after the animals to discover if he or she has noticed anything different about them.
4. Remember you must first watch the animals from a distance, talk to the person who looks after them, and then check the animals. You will then be able to decide what to do next.

9. SPREAD OF DISEASE

- Disease occurs when something goes wrong with the body or part of the, body.
- Diseases can be caused by germs, bad feed, chemicals or injuries.
- Diseases caused by germs are called infectious diseases.
- An infectious disease can spread from one animal to another.

Learning objectives

After studying this unit you should know:

1. How animals become ill?
2. What is meant by the spread of disease?
3. What is an infectious disease?
4. What is a non-infectious disease?
5. How to prevent the spread of disease.

THE MAIN CAUSES OF DISEASE

Disease can be classified as acute or chronic. An acute disease starts quickly and lasts for a short period when the animal either recovers or dies. A chronic disease lasts for a long time and weakens the animal. Diseases are said to be infectious (will spread from one animal to another) or noninfectious (will not spread from one animal to another).

Non-infectious diseases can be caused by poor feed and the lack of minerals, salts and vitamins that the body needs. Non-infectious disease can also be caused by poisoning with chemicals or plants, by cuts, burns and broken bones. Some diseases pass from the parent to the young (hereditary).

Many non-infectious diseases are chronic but they can be acute. They can cause large losses of meat, milk and wool. Working (draught) animals do not work well and the rate of reproduction can be low with the young being born dead or dying before they are weaned. Chronic diseases are often thought to be "normal" but when the cause is known and eliminated production can be greatly increased.

Infectious diseases are caused when the body is attacked by tiny living germs.

SPREAD OF DISEASE

Infectious diseases can be spread by:

1. Direct contact between animals.
2. Germs in feed and water.
3. By faeces and urine from sick animals.
4. By flies, ticks, lice and fleas.
5. By dirty housing or shelters.
6. Young and old animals become infected more easily.

PREVENTING INFECTIOUS DISEASES

1. Animals, like humans, must be clean in order to be healthy. The animal must be provided with clean feed, water, bedding and shelter.
2. Sick animals should be kept separate from the others.
3. Some diseases can be cured by drugs.
4. Vaccination can protect animals against some diseases.
5. Dead animals and waste should be disposed of.

Remember:

The spread of disease can be avoided by good livestock management. Keeping animals together increases the chance of disease spreading by contact. New livestock should be kept separate from the others for two weeks so they can be checked for signs of disease.

Avoid mixing herds. Try to keep herds separate at watering and feeding points.

You should separate and isolate any animal which shows signs of disease.

PREVENTING NON-INFECTIOUS DISEASES

The chronic non-infectious disease may not be recognized as a disease. The affected animals may not die but will not produce as much milk, meat or wool, or work as well as could be expected.

If we continually look for ways of improving feed, water, mineral and vitamin supplies we will find the way to control the non-infectious diseases. This will lead to greater production of wool, meat and milk, draught animals will be stronger and more young will be produced. Poultry will produce more eggs and get fatter.

10. BREEDS IN INDIA

Livestock plays an important role in Indian economy. About 20.5 million people depend upon livestock for their livelihood. Livestock contributed 16% to the income of small farm households as against an average of 14% for all rural households. Livestock provides livelihood to two-third of rural community. It also provides employment to about 8.8 % of the population in India. India has vast livestock resources. Livestock sector contributes 4.11% GDP and 25.6% of total Agriculture GDP.

With the given facts, it is imperative to understand different species and their breeds, which is contributing in human life with some products. In the given document 6 species are profiled namely Cattle, Buffalo, Goat, Sheep, Pig and Poultry with the basic purpose of their rearing.

CATTLE BREEDS:

There are 37 types of notified cattle breeds in India. Cattle are divided into three basic categories on the basis of utility:

- i. Milch Breeds
- ii. Dual Purpose breeds
- iii. Draught Purpose breeds

MILCH BREEDS

These breeds basically are kept for milking, as these are high yield indigenous breeds of the country.

GIR:

- This breed is otherwise called as Bhadawari, Desan, Gujarati, Kathiawari, Sorthi, and Surati.
- Originated in Gir forests of South Kathiawar in Gujarat also found in Maharashtra and adjacent Rajasthan.
- Basic colors of skin are white with dark red or chocolate-brown patches or sometimes black or purely red.
- Horns are peculiarly curved, giving a 'half-moon' appearance.
- Milk yield ranges from 1200-1800 kgs per lactation.
- This breed is known for its hardiness and disease resistance

SAHIWAL:

- Originated in Montgomery region of undivided India.
- This breed otherwise known as Lola (loose skin), Lambi Bar, Montgomery, Multani, Teli.
- Best indigenous dairy breed.
- Reddish dun or pale red in color sometimes flashed with white patches.
- Heavy breed with symmetrical body having loose skin.
- The average milk yield of this breed is between 1400 and 2500 kgs per lactation.

RED SINDHI

- This breed is otherwise called as Red Karachi and Sindhi and Mahi.
- Originated in Karachi and Hyderabad (Pakistan) regions of undivided India and also reared in certain organized farms in our country.
- Color is red with shades varying from dark red to light, strips of white.
- Milk yield ranges from 1250 to 1800 kgs per lactation.
- Bullocks despite lethargic and slow can be used for road and field work.

THARPARKAR

- Originated from Tharparkar district of Sindh (Pakistan)
- In India, it is found in Southern area of Kutch and Sirohi, Jodhpur, Pali and Jaisalmer districts of Rajasthan
- The animal is white and grey in color
- The Dewlap is large and pendulous
- Ears are semi-pendulous and forward facing ears
- Horns of Tharparkar is Lyre shaped
- The cows are good milkers. Lactation yield ranges from 1200-2000 kg/lactation

RATHI

- Native tract of Rathi is Bikaner district of Rajasthan.
- Presently, it is present in Western Rajasthan, Sirsa District of Haryana and Ferozpur district of Punjab.
- The animal generally is white in color with big red patches across the body.
- Horns of animals are backward and outward orientation.
- Dewlap is large and pendulous.
- Animal is hardy and capable of surviving in harsh weather conditions

- Lactation yield ranges between 1500-2500 kg per lactation

DUAL PURPOSE BREEDS:

These breeds are used for both milking and draught purpose. Bulls are of strong built, so these can be used for the purpose of ploughing the field.

HARIANA:

- It was originated from Rohtak, Hisar, Jind and Gurgaon districts of Haryana and also popular in Punjab, UP and parts of MP.
- Horns are small in both male and female.
- The bullocks are powerful work animals.
- Haryana cows are fair milkers yielding 600 to 800 kg of milk per lactation.

KANKREJ:

- It is otherwise called as Wadad or Waged, Wadhia.
- Originated from Southeast Rann of Kutch of Gujarat and adjoining Rajasthan (Barmer and Jodhpur district).
- The horns are lyre-shaped.
- Color of the animal varies from silver-grey to iron-grey or steel black.
- The gait of Kankrej is peculiar called as 1 ¼ paces (sawai chal).
- Kankrej is valued for fast, powerful, draught cattle. Useful in ploughing and carting.
- The cows are good milkers, yielding about 1400 kgs per lactation.

ONGOLE:

- Otherwise known as Nellore.
- Home tract is Ongole taluk in Guntur district of Andhra Pradesh.
- Large muscular breed with a well-developed hump.
- Suitable for heavy draught work.
- White or light grey in color.
- Average milk yield is 1000 kgs per lactation.

KRISHNA VALLEY:

- Originated from black cotton soil of the water shed of the river Krishna in Karnataka and also found in border districts of Maharashtra.
- Animals are large, having a massive frame with deep, loosely built short body.
- Tail almost reaches the ground.
- Generally grey white in color with a darker shade on four quarters and hind quarters in male. Adults females are more whitish in appearance.
- The bullocks are powerful animals useful for slow ploughing, and valued for their good working qualities.
- The average yield is about 900 kgs per lactation.

DRAUGHT PURPOSE OF BREEDS:

These breeds are generally used for draught purpose, as the milk yield from cows is scanty, but bulls are strong for usage in farms and in transportation.

AMRITMAHAL:

- Native tract of this breed is Karnataka state
- Animals are usually grey in color, but darker shades are being found
- Muzzle, feet and tail are black
- Animals have long and sharp horn with black tip, which is a peculiar identification of this breed

NAGORI

- Native tract of this breed is Nagaur district of Rajasthan, but due to strength of the bull, it is used in Rajasthan, parts of Gujarat and Haryana.
- Nagauri breed bulls are very heavy and strong
- Animals generally white and grey color
- The peculiar characteristic of animal is flat forehead, which helps in differentiation from Haryana bulls
- Ears are long and pendulous

EXOTIC BREEDS:

Due to very high productivity of milk in comparison to indigenous breeds, some exotic breeds are very popular in India and are used widely. These breeds are mentioned below:

HOLESTEIN:

- originated from the northern parts of Netherlands, especially in the province of Friesland.
- Largest dairy breed and ruggedly built in shape and possess large udder.
- Breeds have typical marking of black and white that make them easily distinguishable.
- The average milk production of cow is 8000 to 14000 kgs per lactation.

JERSEY:

- Originated from Jersey Island, U.K.
- Smallest of the dairy types of cattle.
- In India, this breed has acclimatized well and is widely used in cross breeding with indigenous cows.
- The typical color of Jersey cattle is reddish fawn.
- Dished forehead; compact and angular body.
- Economical producers of milk with 4.5% fat.
- Average milk yield is 5000-8000 kgs per lactation.

BUFFALO BREEDS:

Buffalo are found mostly in South Asian region. In India of the total world population 55% buffalo population is present. Buffaloes are liked across country due to high milk yield, high fat % and for meat. The major breeds of buffaloes are listed below:

MURRAH:

- Most important breed of buffaloes whose home is Rohtak, Hisar and Sind of Haryana, Nabha and Patiala districts of Punjab and southern parts of Delhi state.
- Otherwise called as Delhi, Kundi and Kali.
- The color is usually jet black with white markings on tail and face and extremities sometimes found.
- Tightly curved horn is an important character of this breed.
- Most efficient milk and butter fat producers in India.

- Butter fat content is 7.83%. Average lactation yield is varying from 1500 to 2500 kgs per lactation.
- Also, used for the grading up of inferior local buffaloes.

SURTI:

- Also, known as Deccani, Gujarati, Talabda, Charator and Nadiadi.
- The breeding tract of this breed is Kaira and Baroda district of Gujarat.
- Coat color varies from rusty brown to silver-grey.
- The horns are sickle shaped, moderately long and flat.
- The peculiarity of the breed is two white collars, one round the jaw and the other at the brisket region
- The milk yield ranges from 1000 to 1300 kgs per lactation.
- The peculiarity of this breed is very high fat percentage in milk (8-12per cent).

JAFFRABADI:

- The breeding tract of this breed is Gir forests, Kutch and Jamnagar districts of Gujarat.
- This is the heaviest Indian breed of buffalo.
- The horns are heavy, inclined to droop at each side of the neck and then turning up at point (drooping horns).
- The udder is well developed with funnel shaped teats.
- The average milk yield is 1000 to 1200 kgs per lactation.
- The bullocks are heavy and used for ploughing and carting.
- These animals are mostly maintained by traditional breeders called Maldharis, who are nomads.

BHADAWARI:

- Home tract of this breed is Agra and Etawah district of Uttar Pradesh and Gwalior district of Madhya Pradesh.
- Medium sized buffalo.
- The body is usually light or copper colored is a peculiarity of this breed. Eye lids are generally copper or light brown color.
- Two white lines 'Chevron' are present at the lower side of the neck similar to that of Surti buffaloes.
- The average milk yield is 800 to 1000 kgs per lactation.
- The bullocks are good draught animal with high heat tolerance.

- The fat content of milk varies from 6 to 12.5 per cent. This breed is an efficient converter of coarse feed into butterfat and is known for its high butter fat content.

NILIRAVI:

- Originated around the river Ravi.
- This breed is found in Sutlej valley in Ferozpur district of Punjab and in the Sahiwal (Pakistan) of undivided India.
- The peculiarity of the breed is the wall eyes.
- Head is small, elongated, bulging at top and depressed between eyes.
- Horns are very small and tightly coiled.
- Bullocks are good for heavy trotting work.
- The milk yield is 1500-1850 kgs per lactation.

MEHSANA:

- Mehsana is a dairy breed of buffalo found in Mehsana, Sabarkanda and Banaskanta districts in Gujarat and adjoining Maharashtra state.
- The breed is evolved out of crossbreeding between the Surti and the Murrah.
- Body is longer than Murrah but limbs are lighter.
- The horns are less curved than in Murrah and are irregular.
- Bullocks are good for heavy work.
- The milk yield is 1200-1500 kgs per lactation.

NAGPURI:

- This breed is also called as Elitchpuri or Barari.
- The breeding tract of this breed is Nagpur, Akola and Amrawati districts of Maharashtra.
- These are black colored animal with white patches on face, legs and tail. The horns are long, flat and curved, bending backward on each side of the back. (Sword shaped horns).
- The bullocks can be used for heavy work.
- The milk yield ranges from 700 to 1200 kgs per lactation.

BREEDS OF GOATS:

Goats play a major role in drought prone areas of the country, as it is a major source of food from animal source and some of the breeds are known for good milk yield also. Some of the varieties are reared for wool also. The goat breeds are mentioned below:

SIROHI:

- Native tract of Sirohi is Southern Rajasthan and borders of Gujarat adjacent to Rajasthan.
- Sirohi breed is majorly reared for meat purpose as it is a large breed.
- Coat color is brown with light brown patches.
- Body is covered with short and coarse hairs.
- Small horns, curved upward and backward.

MARWARI:

- Marwari breed is native of Western and Northern parts of Rajasthan.
- This breed is reared for meat and hair, which is utilized in carpet grade wool production.
- Predominant color of Marwari is black.
- Hair cover is lustrous, which is used in carpet production.
- Udder is well developed.
- Thin upward facing horns.

BEETAL:

- Beetal is native breed of Punjab.
- The basic purpose of its rearing is meat.
- Predominant color is black or brown with spots of different sizes.
- Long and flat, curled and drooping ears.
- Backward and forward slightly curved horns.

JHAKRANA:

- This breed is native of Alwar district of Rajasthan, from where it spreaded across Eastern Rajasthan.
- The animal is reared for meat and milk production
- This breed is considered as one of the largest breeds of goat in India
- The udder is well developed

- The color of breed is black and it has white spots on muzzle and on ears

BARBARI:

- Barbari is native breed of Eastern Rajasthan and Western Uttar Pradesh.
- These animals are reared for meat and milk.
- This is a dwarf breed, white in color with small brown patches.
- The basic characteristic of identification is long beard in males.
- Horns are medium, thick and twisted in upward and backward direction.

JAMNAPARI:

- This breed is found near the flow of Yamuna river, so it is called as Jamnapari
- This breed generally is found in Uttar Pradesh
- This breed is a high yielder, so along with meet it is reared for milk also
- The color is white or light yellowish tan with brown to light brown spots around neck and face
- Highly convex nose with a tuft of hair (Parrot shaped nose)
- Thick hair growth near buttocks known as feather

SURTI:

- As the name represent, the breed is found near Surat and Vadodara district of Gujarat.
- The animal is small in size, which is reared for meat and milk.
- Color of animal is white.
- This breed has well developed udder and is a high milk yielder.
- Ears are medium in size and drooping.
- Feed Efficiency ratio is very high.

BLACK BENGAL:

- Black Bengal is a native breed of Bangladesh and Bengal.
- It is spread across Bengal, Odisha and Bihar.
- As the name depicts color of goat is black, however lower legs are white in color.
- Body is tight and relatively shorter.
- Hairs and skin are smooth.

BREEDS OF SHEEP:

Sheep is important species of livestock for India. It contributes greatly to the agrarian economy, especially in areas where crop and dairy farming are not economical, and play an important role in the livelihood of a large proportion of small and marginal farmers and landless labourers. In our country, sheep is used for wool and meat purpose. The breeds of sheep are enlisted below:

MARWARI:

- This breed is native of Western Rajasthan.
- It is utilized for wool and meat.
- Marwari is white in color, but face is of black color extending to the lower neck area.
- Ears are extremely small and tubular.
- Fleece is white and it is less dense and coarse in nature.
- Both male and female are polled

MALPURA:

- Native tract of this breed is central and east Rajasthan.
- It is reared for meat and wool.
- Skin color is white or light yellow, with face is of light brown color till lower neck.
- The peculiar characteristic of this breed is long legs.
- Both sexes are polled.

MAGRA:

- This breed is predominantly present in North-western Rajasthan, as it's native tract is Bikaner district of Rajasthan.
- This breed is majorly reared for wool and meat
- This breed is medium sized breed
- Light brown patches around white colored face, is typical character of this breed.
- The wool produced by this breed is carpet quality wool.

CHOKLA:

- Chokla is native breed of Churu district of Rajasthan.
- This breed is reared for finest quality of carpet quality wool.
- It is a medium size breed with face is of light or dark brown color till lower side of neck.
- Fleece is thick and relatively fine and it covers belly and hind legs also

MANDYA:

- It is popularly known as Bannur.
- Native tract of this breed is Mandya and Mysore districts of Kanataka.
- It is reared for meat and wool, but wool is of coarse quality.
- It is a small size breed.
- Generally white but sometimes light brown face till neck.
- Typical reverse U-shape conformation from the rear, which makes it a feature for identification.

GADDI:

- This sheep is reared in hilly areas of Himachal Pradesh and Uttarakhand.
- The basic utility of this breed is wool and meat.
- It is a medium size animal.
- Usually white, but tan, brown and black colors are also being seen.
- Males are horned, which are protruding outwards

RAMPUR BUSHAIR:

- Native tract of this breed is hilly terrain of Himchal Pradesh.
- It is medium size breed which is basically reared for wool purpose.
- This breed is usually white in color.
- This breed is known for coarse and thin fleece.
- Legs are devoid of fleece.

BREEDS OF PIGS:

Domesticated pigs, called swine, are raised commercially for meat (generally called pork, hams, gammon or bacon), as well as for leather. Their bristly hairs are also used for brushes. The major breeds of pig are shown below:

LARGE WHITE YORKSHIRE:

- This is one of the heaviest breed of world, which is native breed of Britain.
- The purpose of rearing is quality meat.
- Body color is white with occasional pigmented spots.
- Ears of this breed are erected.
- Snout is of medium length but large in size.
- Mature body weight ranges between 300-400 kg.

LANDRACE:

- Native tract of this breed is Denmark.
- Highest quality of bacon is produced by this breed.
- Large and elongated body is the peculiar characteristic of this breed.
- Generally this breed is white in color, sometimes with black patches.
- White bristles are found across the body.

MIDDLE WHITE YORKSHIRE:

- Middle White Yorkshire is native breed of Britain.
- It is smaller in size than large white Yorkshire.
- Body is of white in color.
- Snout is small but thick, which is peculiar characteristic of this breed.
- This breed is reared due to high lean meat to bone ratio.

GHUNGHROO:

- It is indigenous breed of pig, which is developed in North East region.
- This breed is black in color
- Bull dog face appearance is the key characteristic of this breed.
- Can produce high quality pork by utilizing kitchen waste
- This breed is known for its very high rate of proliferation.

BREEDS OF POULTRY:

Poultry farming in India, in spite of several constraints, has progressed considerably during the last decade. India stands as third largest egg producer and fifth chicken meat producer in the world with about 60 billion eggs and 2.2 million metric tons of chicken meat. Major Poultry breeds in India are shown below:

RHODE ISLAND RED:

- Rhode Island Red is native breed of United States of America.
- Rust Colored feathers are typical characteristics of Rhode Island Red.
- This breed has red orange colored eyes and a red colored beak.
- This breed is known for high capability of egg laying.

BLACK AUSTRALORP:

- The native breed of Australia is known for its black colored feather with beetle green colored sheen.
- This breed has entirely red colored face.
- This is a large, heavy and beautiful breed.
- It is an excellent layer, so it is reared for eggs generally.

WHITE PLYMOUTH ROCK:

- The native breed of United States is known for excellent quality of meat.
- It is white or barred in color and red mouth appearance.
- Skin color of this breed is yellow.

LEGHORN:

- Leghorn is breed from Italy, which is reared for eggs, as it is excellent egg layer.
- The skin color is yellow, with white feather.
- The head is red in color.

MINORCA:

- Native tract of Minorca is Spain and it is generally used for egg production.
- Skin color of Minorca is yellow with black feathers.
- The comb and wattle are red in color and are large in size.

KADAKNATH:

- This is breed of Central India, which is now eared across country for meat, egg and for medicinal use.
- The color of this breed is completely black.
- Black plumage with a greenish iridescence
- The meat is of black in color have medicinal value.

GIRIRAJA:

- Giriraja is an indigenous breed, of which native tract is Karnataka.
- It is generally reared for eggs.
- It is a disease resistant breed, which is brown or dark brown in color.

11. WHAT IS ANIMAL BREEDING?

Mating of good quality animals to produce highly productive and suitable animals for enhancement overall performance in the subsequent generations and to augment production and profitability.

MATING SYSTEM:

There are two types of mating of animals for production of the progenies. These are

- Natural propagation/mating: Mating of animals by natural means.
- Artificial insemination (AI): Mating is done through artificial means by collecting semen from male and the inseminating the females. This method help in use of outstanding males for mating of a large number of females thereby production of large number of highly productive and performing progenies.

SYSTEM OF BREEDING:

Basically, there are two methods of breeding which are as follows:

1. Inbreeding: Breeding of the related animals as sire (male) and dam (female) are known as inbreeding.
2. Out breeding: Out breeding of unrelated animals as male and female is known as out breeding.

There are again two types of inbreeding which are:

- a) Close breeding: This is most intensive breeding where animals are very closely related and can be traced back to more than one common ancestor, Examples: Sire to daughter Son to dam Brother to sister
- b) Line breeding: Mating animals that are more distantly related which can be traced back to one common ancestor. Examples: Cousins Grandparents to grand offspring, Half-brother to half-sister.
Line breeding increases genetic purity amongst the animals of progeny generations.

Inbreeding i.e. mating of related individuals often results in a change in the mean of a trait. Performance of inbred animals lowers down the reproductive efficiency and may have several disorders. Hence, this method of breeding is not practiced for livestock improvement. However, inbreeding is intentionally practiced to create genetic uniformity of laboratory stocks and to produce stocks for crossing (animal and plant breeding).

But inbreeding is unintentionally generated by keeping small populations for breeding and during selection.

Out breeding system i.e. breeding of unrelated animals is generally of two types:

- a) Crossbreeding: Crossbreeding is the mating of two animals of different breeds. Superior traits that results in the crossbred progeny from crossbreeding are called hybrid vigor or heterosis.

Grading up is the breeding of animals of two different breeds where the animals of an indigenous breed/genetic group is mated by an improved pure breed for several generations towards attaining the superior traits of the improved breed. Grading up is continuous use of purebred sires of the same breed in a grade herd. By fifth generation, the graded animals may reach almost purebred levels.

By following out breeding system i.e., crossbreeding, selective breeding and grading up according to the need results in improvement in production performance of the crossbred/graded along with improvement in growth rate, reproduction and production.

General Considerations Regarding Crossbreeding Systems:

- a) Good record keeping of the animals is required for selection good quality of male and females for breeding. Records on milk production and age at first calving are two important characters besides others.
- b) Calving difficulties may increase when crossing large breed sires with small breed dams and hence selection of animals/breeds should be done carefully.
- c) Fewer calving problems if large breed dams are used. However, large breed dams have higher maintenance costs.
- d) Artificial insemination allows access to better bulls which may be practiced.

CATTLE BREEDING POLICIES AND PROGRAMMES IN THE PLANNING PROCESS:

It is necessary to see how the issues relating to Cattle Breeding have been dealt with in the successive Plan periods starting from the First Five Year Plan. It is seen that the cattle breeding strategies has been handled in different ways in the various Plan documents with varying degrees of emphasis in different Plans. At present the issue is discussed at great length in regard to issues like development of Indian indigenous cattle breeds, their genetic improvement and breeding strategies etc.

SELECTION OF BREEDING ANIMALS:

Selection of good quality improved animals for breeding is done by allowing some animals to have offspring while preventing the animals with inferior quality from reproducing. The process allows producing genetically superior animals. Emphasis has to be given on several traits when selecting breeding stock.

Benefits and advantage of Selection and Breeding i.e., Selective breeding, cross breeding, Grading up: The advantage and benefits of selection and breeding are increase productivity eg., milk yield, fat yield, lowered age at first calving etc. in the subsequent generations in cattle besides improvement in reproductive rates, growth rate of the progenies. This increases income generation per animal.

1. How and why the crossing is done between two selected breeds
2. Whether the participants able to understand the impact of breed improvements

12. RUMINANTS

ANIMALS CARNIVORE, OMNIVORE AND HERBIVORES

Learning objective

After studying this unit you should know:

1. What are the animal groups?
2. What is the rumen.
3. What makes the ruminant different?
4. Why animals chew the cud (*ruminates*).

Who eats what

Animals are divided into three groups:

➤ Carnivores which eat meat,	e.g. dog, lion
➤ Omnivores which eat meet end plants,	e.g. pig
➤ Herbivores which eat plants	e.g. cow, horse

In herbivores, the digestive system is very large because they eat large amounts of grass.

- The horse, donkey and mule are herbivores but do not chew the cud. They are non-ruminants.
- Cattle, goats, sheep and buffalo chew the cud. They are ruminants.

THE RUMEN (STOMACH)

The stomach of a ruminant has four chambers. The first chamber is very large and is called the rumen. The second chamber is the reticulum (honeycomb). The third is the omasum (book) and the fourth is the abomasum (the true stomach). The ruminant chews grass and swallows and it goes into the rumen.

THE RUMEN (STOMACH)

When the ruminant has finished eating, the food is brought back up and rechewed. This is called chewing the cud or rumination. If the animal stops ruminating this is a sign of ill health.

Ruminants make a lot of gas in their stomachs and belch once every minute, (unlike people they belch silently). If the belching stops the stomach swells with gas. We call this bloat or tympany.

RUMEN MOVEMENT

The rumen moves regularly and contracts about once every minute. By putting your fist on the left flank (in the hollow behind the ribs) you will be able to detect the contractions. Regular contractions are a sign of good health.

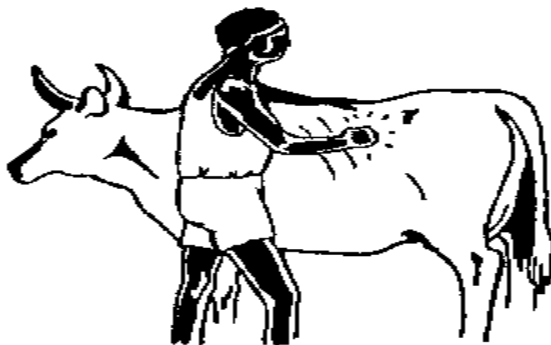

FIGURE 12: RUMEN MOVEMENT

NAILS AND WIRES IN THE RUMEN

Because ruminants eat quickly they can swallow objects like nails and wires with their feed. These objects can damage the rumen and can pass through the wall of the rumen into the heart and kill the animal.

You should tell your community to keep nails, wires and similar objects away from animal feed and pasture.

13. HOW TO AGE SHEEP, GOATS, CATTLE AND BUFFALO

The age of animals can be determined by examination of the front teeth. You will not be able to determine the exact age, especially in older animals.

Learning objectives: After studying this unit you should know:

1. How to hold animals to check the teeth.
2. The difference between the temporary (milk) teeth and the permanent teeth.
3. How to age sheep, goats, cattle and buffalo.

HOW TO HOLD (RESTRAIN) THE ANIMALS TO CHECK THEIR TEETH



FIGURE 13: HOW TO HOLD SHEEP AND GOAT TO CHECK THEIR TEETH



FIGURE 14: HOW TO HOLD CATTLE AND BUFFALO TO CHECK THEIR TEETH.

TEMPORARY (MILK) AND PERMANENT TEETH

Young animals, like children, have temporary or milk teeth which will be replaced by permanent teeth. Young ruminants have 20 temporary teeth, adult ruminants have 32 permanent teeth.

Temporary (milk) teeth:		
Upper jaw	No front teeth	6 back teeth
Lower jaw	8 front teeth	6 back teeth
Permanent teeth:		
Upper jaw	No front teeth	12 back teeth
Lower jaw	8 front teeth	12 back teeth

TABLE 2: TEMPORARY (MILK) AND PERMANENT TEETH

Remember that you will not be able to determine the exact age of the animal from its teeth, but there will be a few months either way.

You should develop the habit of regularly checking the teeth (not just for age) because bad or worn teeth will stop an animal eating or chewing the cud. Such an animal is of no use.

AGE OF GOATS AND SHEEP

1. Animal under one year old (no permanent teeth)
2. One year old (2 permanent teeth)
3. Two years old (4 permanent teeth)
4. Three years old (6 permanent teeth)
5. Four years old (8 permanent teeth)
6. Old animal, more than four years old

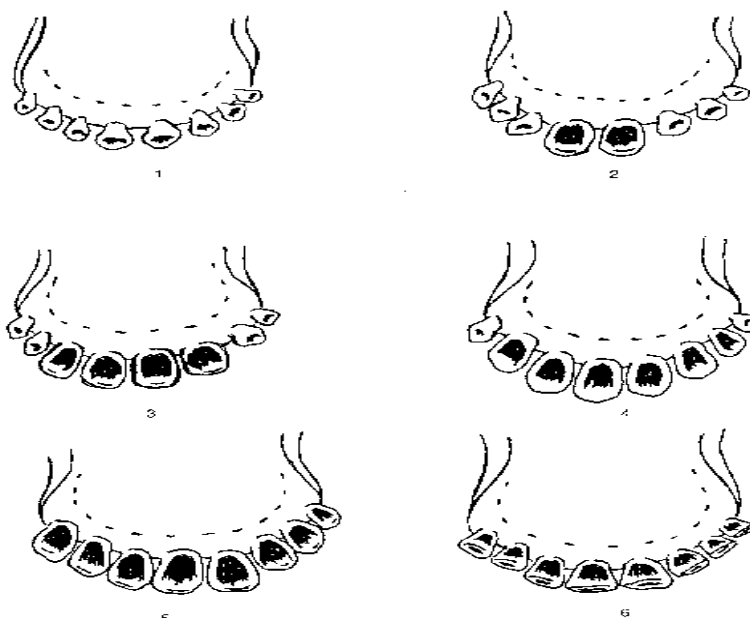

FIGURE 15: AGE OF GOATS AND SHEEP

AGE OF CATTLE

1. Under two years old (No permanent teeth)
2. Two years three months (2 permanent teeth)
3. Three years old (4 permanent teeth)
4. Three years six months (6 permanent teeth)
5. Four years (8 permanent teeth)

6. Old animal, over four years old.

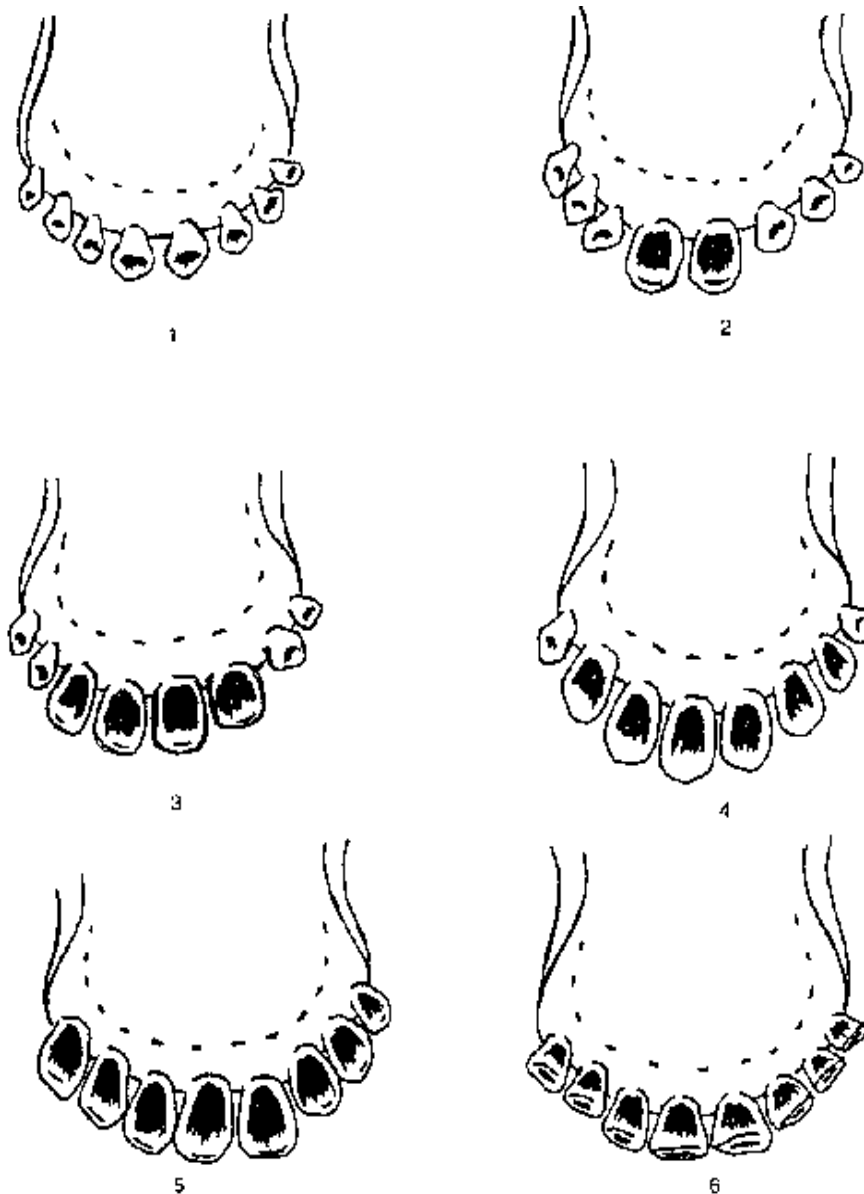

FIGURE 16: AGE OF CATTLE

AGE OF BUFFALO

1. Under three years old (no permanent teeth)
2. Two years six months (2 permanent teeth)
3. Three years six months (4 permanent teeth)
4. Four years six months (6 permanent teeth)
5. Five to six years (8 permanent teeth)

6. Old animal

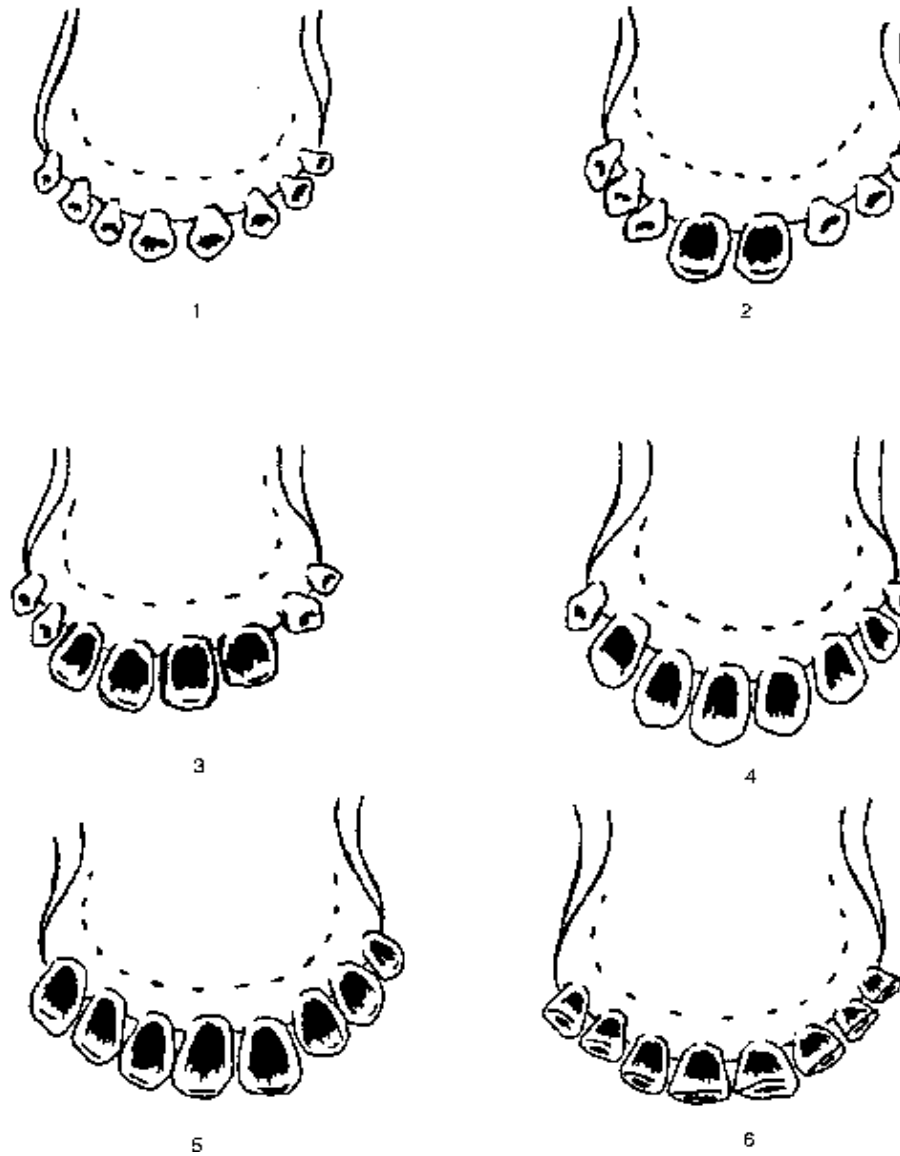

FIGURE 17: AGE OF BUFFALO

14. RESTRAINING CATTLE AND BUFFALO

Handling cattle and buffalo may lead to stress and injuries especially if the animals are not used to being handled and the handler is not experienced.

There are different techniques used to restrain and cast (throw) these large ruminants.

Learning objectives

After studying this unit you should know:

1. How to hold cattle and buffalo.
2. How to safely use the halter
3. How to cast (throw) the animals with ropes.

RESTRAINING (CONTROLLING) LARGE RUMINANTS

The crush or race is made of wood or metal. You should have one in your village or settlement, if not you should talk to the elders of the community about making one with the help of a veterinarian. Crushes are used for large ruminants when they are vaccinated, examined or undergo other treatments.

HOW TO HOLD ANIMALS

If you do not have a halter or a nose holder the best way to hold a large ruminant is to take a firm grip of the nostril using the thumb and forefinger of one hand while holding the horn or the ear with the other hand.

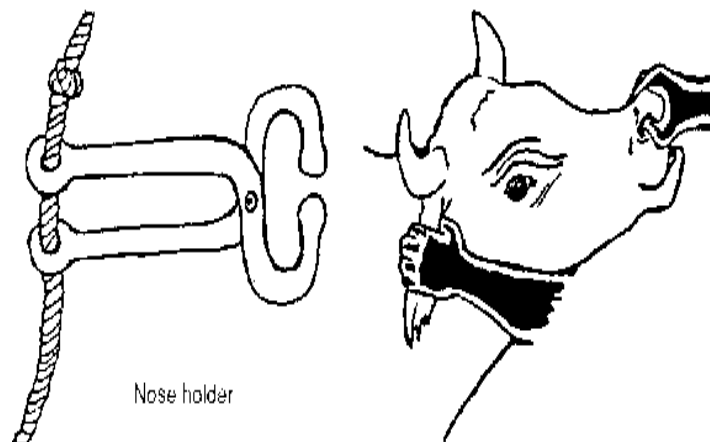

FIGURE 18: HOW TO HOLD ANIMALS (NOSE HOLDER)

HALTERING LARGE RUMINANTS (CATTLE AND BUFFALO)

Animals need to be halter-trained and this is best done when they are young so that they are accustomed to the halter. When a halter is used on an animal talk to the animal to encourage it to move. Hold the halter no more than 20 cm from the animal cheek and walk close to its neck.

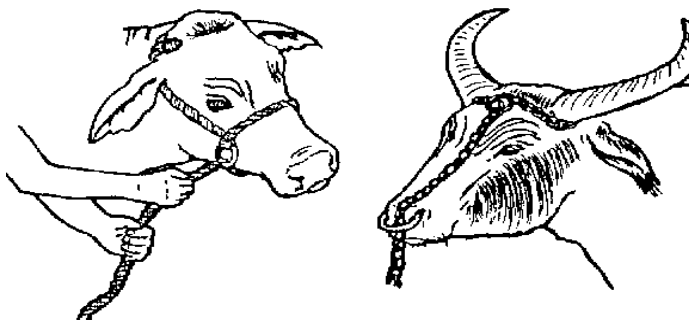

FIGURE 19: HALTERING LARGE RUMINANTS (CATTLE AND BUFFALO)

CASTING OR THROWING CATTLE AND BUFFALO

If you do not have a crush and you want to trim the hooves of an animal it will be necessary for you to cast (throw down) the animal.

To do this you will need:

1. A halter for the head.
2. Two people to help you.
3. Ten to twelve metres of strong rope.
4. A place where it is safe to throw the animal, where the soil is soft or covered with straw.

First halter the animal then tie the long rope around it as shown in the illustration below. Have one person to hold the halter while the other joins you and pulls the rope. The animal will collapse onto the floor and your helper must immediately put his knee on its neck and his hand on the animal's head to prevent it from rising.

Do not leave the animal down for a long time as bloat may develop.

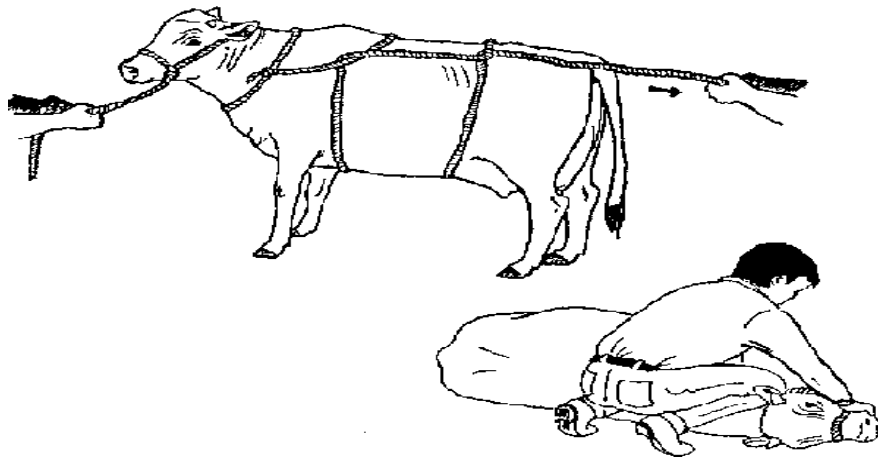

FIGURE 20: CASTING OR THROWING CATTLE AND BUFFALO

Remember when casting animals that both the animal and people can get injured so try to do it safely.

15. FOOT (HOOF) CARE

There is an old saying "No foot, no animal". This is true as untrimmed feet lead to bad legs and the animal cannot graze properly and will lose condition.

The feet should be regularly examined and trimmed.

Remember to make any cuts in a direction away from your body or the hand holding the foot.

Learning objectives

After studying this unit you should know:

1. Why overgrown feet are bad.
2. How to hold or cast animals in order for the feet to be trimmed
3. How much of the foot (hoof) can be removed.

OVERGROWN FEET

The hoof is like your fingernail and grows continuously. Walking wears the hoof down but sometimes the hoof grows very quickly and becomes overgrown. In some places where the ground is too wet the foot can get infected and it becomes smelly and painful. This condition is called foot rot and the animal can become lame.

When animals have infected or overgrown feet they cannot walk and graze properly. The male cannot mount the female and is useless.

HOW TO HOLD OR CAST ANIMALS IN ORDER TO TRIM THE FEET

You can trim the feet of sheep and goats alone or with someone to help you. Grasp the wool or hair on the chest with one hand while holding the animal on its flank with the other hand. Use your knee to push against the animal's back and force it into a sitting position. The animal can be kept in this position for a long time while the feet are trimmed.

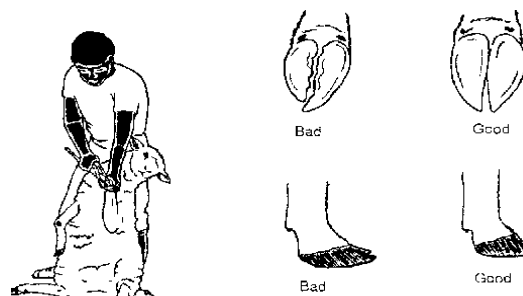

FIGURE 21: HOW TO HOLD TO TRIM FEET'S

In order to trim the feet of cattle or buffalo you will need to cast the animal. The leg may be lifted and tied as shown.

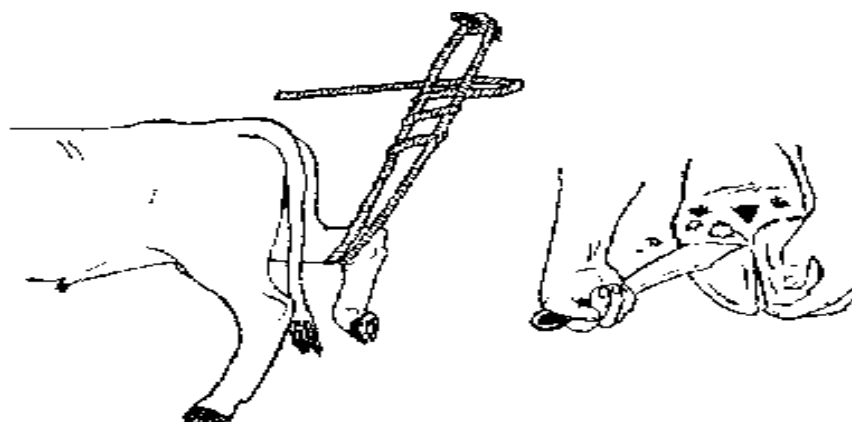

FIGURE 22: LEG MAY BE LIFTED AND TIED

TRIMMING THE FEET

You will need any suitable sharp tool such as a knife, hoof cutter large carpenter's rasp, or sharp carpenter's pincers.

Cut the overgrown claw of the hoof by carefully taking off a little at a time. STOP if bleeding occurs. Do not cut down too far. Like your fingernail the hoof has a sensitive area which if cut into will become painful and infected. STOP if the foot (sole) springs back when pushed with the thumb. When you have cut the hoof down use a rasp, if you have one, to file and neaten the edge of the hoof.

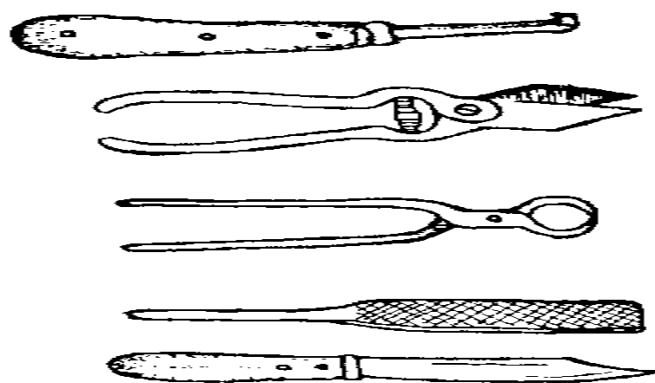

FIGURE 23: SHARP TOOL FOR TRIMMING FEET

If the foot is infected and wet and smelly you should carefully remove the damaged areas so that the infected area is exposed to the air. The infected area should then be painted with tincture of iodine or formalin. Repeat the treatment every 2 days.

Remember to use whatever tools you can and look after the animals' feet. If you regularly check the feet and keep them trimmed you will not have any problems. If you have sheep, and there is a lot of foot rot in your area, ask your veterinary service for advice and a vaccine against foot rot.

16. SHEEP AND GOAT HOUSING

Sheep and goats are important sources of milk and meat. Both readily adapt to a wide range of climates and available feed supplies. They also have similar housing requirements and will therefore be treated together.

MANAGEMENT SYSTEMS

Depending primarily on the availability and use of land, three systems of production are practiced:

- 1 Subsistence, in which a few animals are tethered during the day and put into a protective shelter at night.
- 2 Extensive, in which the flock/herd grazes over large areas of marginal land unsuited to agriculture. The flock is usually shut into a yard at night. Both these systems are practiced extensively in East Africa.
- 3 Intensive, in which the animals are confined to yards and shelters and feed is brought to the flock. This system offers the greatest protection for the flock from both predators and parasites. Although it may make the best use of limited land resources, this system also increase labour and the capital investment required for facilities.

HOUSING

Housing in tropical and semi-tropical regions should be kept to a minimum except for the more intensive systems of production. In the arid tropics, no protection other than natural shade is required. In humid climates, a simple thatched shelter will provide shade and protection from excessive rain. Sheep and goats do not tolerate mud well; therefore, yards and shelters should be built only on well drained ground.

Figure 10.54 shows a sheep/goat house for 100 animals. Unless predators are a serious problem, gum poles can be substituted for the brick walls. If thatching is difficult to obtain, a lower pitch roof of galvanized steel is feasible, but some insulation under the roof is desirable.

Where housing facilities are provided, it will be necessary to have in addition to water, feed troughs and permanent partitions, provision for temporary panels to help divide and handle the flock when necessary to carry on such operations as disease treatment, docking, shearing, milking and lambing.

In temperate climates and at high altitudes a more substantial structure may be needed. An open-front building facing north provides wind protection and a maximum of sunshine. A rammed earth floor with a slope of 1:50 toward the open front is recommended. A concrete apron sloped 1:25 and extending from 1.2m inside to 2.4m outside will help maintain clean conditions in the barn.

	Weight	Floor Space			Trough Space
		Solid Floor	Slatted Floor	Open Yard	
	kg	m ² /animal	m ² /animal	m ² /animal	m/animal
Ewe/ Doe	35	0.8	0.7	2	0.35
Ewe/ Doe	50	1.1	0.9	2.5	0.40
Ewe/ Doe	70	1.4	1.1	3	0.45
Lamb/ Kid		0.4 - 0.5	0.3 - 0.4	-	0.25 - 0.30
Ram/ Buck		3.0	2.5	-	0.5

TABLE 3 :RECOMMENDED FLOOR AND TROUGH SPACE FOR SHEEP/ GOATS IN INTENSIVE PRODUCTION RELATED TO LIVE WEIGHT

Slats shall be 70 to 100mm wide, 25 to 30mm thick and laid with 25mm spaces. Individual lambing pens should be 1.5m depending on the weight of the ewe and number of lambs expected.

A feed trough should be 0.3 to 0.4m deep front to back and have a 0.5 to 0.6m high front wall facing the feed alley

In areas of high rainfall it may be desirable to keep the animals off the ground. Stilted houses with a slatted floor which is raised 1 to 1.5m above the ground to facilitate cleaning and the collection of dung and urine are shown in Figures 10.55 and 10.56.

Milking can be facilitated by providing a platform along the feeding fence where the animals can stand while being milked from behind. Such a platform should be 0.8m deep and elevated 0.35 to 0.5m above the floor where the milker stands.

PARASITE CONTROL

A dipping tank and crush are essential in the layout for a large flock or for a community facility for the use of many small holders. A typical dipping tank is shown. In areas where the Bont tick is a problem, simple walk-through tanks or footbaths may be needed.

17. NUTRITION AND MANAGEMENT OF SHEEP AND GOATS

INTRODUCTION

Considerable research work has been carried out with sheep, mainly mutton breeds, but less attention has been given to dairy sheep and particularly goats as milk or meat producers although milk yield and milk composition of goats have been reported. It is difficult to describe the feeding and management of the sheep and goat industry around the world because of the many interacting factors such as production system, management system within each production system, genetic potential of the breeds, biological constraints etc. The systems of sheep and goat production can be divided into the following categories:

1. Fine wool production from sheep and goats as the main products and meat as a byproduct.
2. Meat production from sheep and goats as the main product and wool, fiber and skin as byproducts.
3. Dual purpose sheep and goats with the main emphasis on milk or meat production or milk and meat given equal importance.

Within the meat and dual production systems the following four management systems can be identified:

1. Extensive (migratory, free range, pasture or range grazing).
2. Semi-intensive (pasture or range grazing, use of supplementary feeding mainly on crop residues and conserved roughage).
3. Intensive (grazing on improved pastures, zero grazing, conserved forage, crop residues and increased use of concentrates).
4. Tethering (small size flocks of 2–10 animals). This is a subsistence family system and the animals live on kitchen remnants crop residues, grazing near inhabited areas and other supplementary feed).

In the migratory system sheep and goat farmers make use of the seasonal pastures located in different areas. In the mountainous regions of Asia, Europe and North America climatic conditions limit growth of vegetation in winter and so flocks are moved to lowlands; in summer flocks are moved to highlands where feed is available. In the semi-arid and arid regions land use is seasonal and movement of the animals is dictated by rainfall and availability of grazing.

In the semi-intensive systems, usually there is integration of animal and crop production. Moving from the extensive to the intensive systems of production the performance of animals is improved and higher inputs used with the objective of obtaining a high output of product.

THE NUTRITION OF SHEEP AND GOATS

NUTRIENT REQUIREMENTS

It is extremely difficult to present data collected from all over the world on the nutrient requirements of sheep and particularly of goats. For this reason, as a general guide the recommended minimum requirements of sheep and goats are suggested. The energy requirements of sheep and goats are similar according to. For dry non-pregnant animals, the maintenance requirements are 0.42 MJME/kg^{0.75}.

During the first 15 weeks of pregnancy energy requirements increase by 15%, providing also for a slight weight gain, and during the last stages of pregnancy they increase by 80–100% compared with dry animals. For each kg of sheep milk (6% fat) and goat milk (4%) 7.5MJME and 5.2MJME are required, respectively. The requirements for digestible crude protein range from 2.3 – 2.8g /kg ^{0.75} for sheep and goats for maintenance, increasing during the last stages of pregnancy by 80–100%. For each kg of goat milk or sheep milk 45–70 g or 60–90 g digestible crude protein is required, respectively.

FEEDING BEHAVIOUR

Studies on the foraging behavior and the dietary habits of sheep and goats (type and parts of plants they eat, their tolerance to saline or bitter feed and saline water, the distance of travelling to find food, the frequency of drinking and their walking ability) can provide assistance to range managers for making the right management decisions and improving sheep and goat performance. Goats have been considered more efficient in the digestion of crude fiber and the utilization of poor roughages than. Possible physiological and behavioral factors for this ability of the goat have been indicated. However, with medium and good quality forage and adequate feed availability goats apparently are similar to sheep.

NUTRITION AND REPRODUCTION

Inadequate nutrition, particularly of energy, depressed the reproductive performance of extensively or intensively managed sheep and of Indian breeds of goats. Sexual maturity of sheep and goats is advanced by good feeding and the energy stimulates estrus activity within the normal breeding season, ovulation rate, fertilization and survival of ova and the maintenance of the resultant embryos to term as viable lambs.

Body condition at mating, achieved over a longer period i.e. the period between one reproductive cycle and the next, has a greater effect on ovulation rate and barrenness than flushing (i.e. increasing the level of nutrition in the immediate pre-mating and mating period). High producing dairy ewes or goats, require a dry period to achieve maximum prolificacy.

The level of feeding after weaning of female lambs or kids intended for replacements depends on the age at mating. Usually lambs or kids are mated for the first time when they reach 60–80% of their mature weight. This weight is accomplished with proper feeding and management at the age of 8–10 months.

NUTRITION AND PREGNANCY

There is a very slow growth of fetus during the first 100 days of gestation with more than 80% taking place during the last 8 weeks of gestation. Stress in pregnant goats during late pregnancy increased with increasing kidding percentage as indicated from the total birth weight of kids as a percentage of the dam's weight which was 8, 13.5 and 18.5 for goats giving birth to singles, twins or triplets, respectively. This means that a 50-kg ewe carrying twins would have an energy requirement of about 2.5 to 3 times that of a non-pregnant ewe. However, these full requirements are not recommended and 25% lower requirement would reduce birth weight of lambs by only 10% which is acceptable on both biological and economic considerations. Low levels of energy during late pregnancy lead to pregnancy toxemia particularly with goats. However, high levels of feeding through pregnancy can lead to pregnancy toxemia in sheep and kidding difficulties.

NUTRITION AND LACTATION

Lactating sheep and goats have increased requirements for all nutrients. Different methods of estimating milk yield in sheep and goats have been developed which are useful in evaluating the results of various management systems. The lamb suckling technique or the use of oxytocin and milking have been widely used to obtain information in the non-dairy ewe whereas with dual purpose sheep and goats a combination of the suckling technique and milking until weaning is used. Hand or machine milking after weaning have also been used.

NUTRITION OF LAMBS AND KIDS

BIRTH TO WEANING

The weight gain of suckling lambs and kids is closely associated with the level of milk intake during the early stages of the milk feeding period and declines with declining milk production. One unit of lamb live weight gain results from 5 units of sheep milk consumed, while one unit of kid live weight gain results from 7 kg of goat's milk.

Weaning of lambs and kids can take place from 4 weeks to 5 months of age, depending on the management system. With either artificial rearing or natural suckling the success of early weaning systems onto solid food depends on the state of rumen development at weaning which is governed by the ingestion of solid

feed. Solid feed intake is negatively related to milk intake and after the age of 3 weeks' milk should be offered less than ad libitum. Good quality creep feed and roughage should be available to lambs and kids from the age of two weeks.

When the milk supply of ewes or goats is inadequate or absent or when it is necessary to remove the progeny as part of the management system artificial rearing is practiced. The lambs or kids are given colostrum within 6–10 hours after birth and weaning within 24 hours after birth is ideal; later weaning increases difficulties of training the lambs or kids to suck from teats. Milk substitute can be given warm or cold and should contain 20–25% protein and 25% fat for lambs and 16–24% fat and 20–28% protein for kids. Good milk replacers have conversion rates of milk solids into lamb gain of 1:1 and for kids 1.1 to 1.3. With dual purpose systems and when artificial rearing is practiced the amount of milk replacer fed until weaning is minimized, either with early weaning or restricted milk intake, in order to reduce feed and labour costs. When natural suckling is practiced the adoption of early weaning and partial suckling with the objective of increasing commercial milk, yields is of great importance. However, the growth of the offspring should not be affected by the lower milk consumption.

WEANING TO SLAUGHTER

The performance of lambs grazing poor pastures is low because of low feed intake (inadequate feed supply and low quality roughage) resulting in low energy intake. The importance of adequate nitrogen intake in relation to energy intake for the performance of lambs and kids has been extensively studied. Feed intake, daily gain and feed efficiency of lambs were improved considerably by supplementing a low-quality roughage diet with protected protein and glucose infusion directly into the abomasum.

It is apparent that sheep and goat fattening must be based on diets of high energy concentration and adequate in protein. The protein requirement of male lambs declines from 18% crude protein in the dry matter in the early stage of life to 12% at live weights above 40 kg while those of female lambs are about 2% units lower. Male kids responded linearly to increased protein level in the diet whereas female response was marginal. Growth response of kids to level of protein tend to decline at higher live weight and/or age than lambs.

When urea was substituted for soybean as the protein source for lambs carcass gain, feed intake and feed efficiency were reduced during the period from 2 weeks to 3 months of age. From 3 months of age to 45 kg live weight only feed efficiency was reduced by urea.

The physical form of concentrate diets affects efficiency which is lower on a mash diet than on pelleted or whole grain diets for both lambs and kids.

The slaughter weight of lambs and kids depends on the desired carcass quality and on seasonal price trends and also on the live weight which minimizes total cost per kg carcass. Generally, lambs are slaughtered at about half the mature weight of the parents, whereas in the United States lambs are slaughtered at even higher live weights. With increasing carcass weight the fat content and calorific value of carcass increase and water content, ash and protein contents decrease. The dressing percentage and chemical fat content were increased by fattening in the feedlot and diets deficient in protein increased the fat to lean ratio in growing lambs. Goat carcasses have less fat than those of lambs. Females have fatter carcasses, at the same live weight, than males with castrates intermediate. Castration leads to reduced growth rate, a fatter carcass and reduced feed conversion efficiency. However, a taint of varying intensity was present in the meat of intact goats but not in that from the castrates. Where feeding conditions are good ram lambs and male kids can often be slaughtered before there is any need for castration.

MANAGEMENT OF SHEEP AND GOATS

FEED INTAKE

The aim in sheep and goat feeding is to feed as much forage as possible and satisfy the largest part of requirements. The quantity and quality of roughage available will determine the amount and type of supplement to be fed. The higher the quality of the roughage, the higher the intake and performance with sheep or goats on all roughage diets. The voluntary intake of lactating ewes and goats is 50 to 100% higher than dry animals. The level of feed intake immediately after parturition is low but it increases steadily after parturition and maximum intake is reached 2–3 weeks after milk yield peaks. Small amounts of nitrogen (soybean meal or urea) and energy (grains) increase both the roughage and the total digestible energy intake.

MANAGEMENT OF SHEEP AND GOATS DURING THE REPRODUCTIVE CYCLE

With one lambing every year the time between weaning and mating should enable ewes to replenish losses from the previous lambing. It is not advisable to improve nutrition, for example before mating only, resulting in higher ovulation and conception rates without making provision for the additional nutritional needs in late pregnancy and early lactation. The most critical parts of the reproductive cycle must be corrected and not just at mating, or late pregnancy or early lactation.

In intensive sheep and goat systems feeding is based on the nutrient requirements of the animals and the nutritive value of feeds with the formulation of a ration which meets the daily requirements of the animals. Under these conditions feed intake of sheep and goats can easily be measured and available feedstuffs can be given in quantities needed to maintain good body condition. For example, at the declining stage of lactation feed is offered according to milk yield. Twin suckling ewes are fed separately from single suckling

ewes, or yearlings. During late pregnancy, better nutrition is given to yearlings and leaner ewes and early and late lambing ewes and goats are also fed separately. Sheep and goats in intensive systems may rely on large quantities of crop residues or on small quantities of roughage and crop residues with higher quantities of concentrates. The use of concentrates is justified only if local meat and milk prices are high.

With semi-intensive and particularly extensive systems of management supplementing grazed roughage which varies in quantity and quality is a problem. In temperate climates, there is usually adequate pasture and supplementation arises only when there is overstocking or when the time of lambing is changed for example with lambing at the end of the grazing season. In highlands as well as in tropical, semi-arid and arid regions the production of roughage is seasonal and varies widely both in quantity and quality. Under these conditions grazing sheep and goats respond to energy, protein and phosphorus supplements when grazing poor quality roughage and vitamin A when animals subsist on dry roughage for more than 4 months.

There is no doubt, particularly with extensive systems of management, that the situation can be improved with increasing the feed resources. Either by increasing the available land and thus increasing roughage production or by improvement of the existing land for increasing production or by supplementary feeding. In addition to increased roughage production and supplementary feeding, improved flock management is necessary. Stocking rate must be decided according to the animal carrying capacity at the worst time of the season, unless supplementary feeding is available at times of roughage scarcity. Part of the existing pasture can be improved and fenced. This area is reserved for grazing when most needed. In these improved areas animals may be brought at mating, during late pregnancy and early lactation. Leaner ewes or ewes suckling twins and yearlings can also make use of the reserved areas. When the quantity of pasture produced from this improved and reserved pasture is not adequate, crop residues, hay, silage and concentrates are used to supplement the animals at times of need.

CROP RESIDUES AND AGRO-INDUSTRIAL BY PRODUCTS

Crop residues and agroindustry byproducts can play an important role in the feeding of sheep and goats in all management systems. Such residues can supply a substantial part of the maintenance requirements of all ruminants in the Asian region. Usually their nutritive value is low, mainly because they are deficient in nitrogen and energy. They have to be supplemented when fed to ruminants or their quality must be improved before feeding.

Cereal straw is an important roughage resource and its nutritive value can be improved with nitrogen supplementation. The use of poultry litter in the diets of ruminants is possible provided it contains no pathogens, drugs or other medicants.

REPRODUCTIVE ORGANS AND THEIR MAJOR FUNCTIONS

FEMALE

The reproductive tract of ewes and does is similar and, hence, discussed together. The female reproductive tract consists of the vulva labia, vagina (copulatory organ), cervix, body of the uterus, uterine horns, oviduct (also called Fallopian tube) and the ovary.

Ovaries: The ovaries contain the ova (eggs), and secrete female reproductive hormones (progesterone and estrogens).

Oviduct: The oviduct opens like a funnel (the infundibulum) near the ovary. The infundibulum receives ova released from the ovary and transports them to the site of fertilization in the oviduct. The oviduct is involved in sperm transport to the site of fertilization, provides a proper environment for ova and sperm fertilization, and transports the subsequent embryo to the uterus.

Uterus: The uterus consists of two separate horns (coruna). In animals with multiple births, each horn can contain one or more fetuses. The uterus provides a proper environment for embryo development, supports development of the fetus (supplying nutrients, removing waste, and protecting the fetus), and transports the fetus out of the maternal body during birth.

Cervix: The cervix is the gateway to the uterus and is a muscular canal consisting of several folds of tissue referred to as “rings.” The cervix has relatively little smooth musculature. It participates in sperm transport, and during pregnancy, blocks bacterial invasion. The mucus produced during pregnancy (also during the luteal phase) forms a plug that makes the opening through the cervix impermeable for micro-organisms and spermatozoa.

Vagina: This is the exterior portion of the female reproductive tract and is the site of semen deposition during natural mating.

Vulva: barrier for preventing external contamination of the female reproductive tract.

MALE

The male reproductive system consists of testicles, which produce sperm and sex hormones, a duct system for sperm transport, accessory sex glands, and the penis, or male organ of copulation, which deposits semen in the female.

Testes: The testes are paired organs which descend from the abdominal cavity during fetal development to lie in the scrotum. They produce the male gametes (spermatozoa) and secrete the male sex hormone, testosterone. Testosterone is essential for the development of male characteristics, maintaining normal sexual behavior and sperm production.

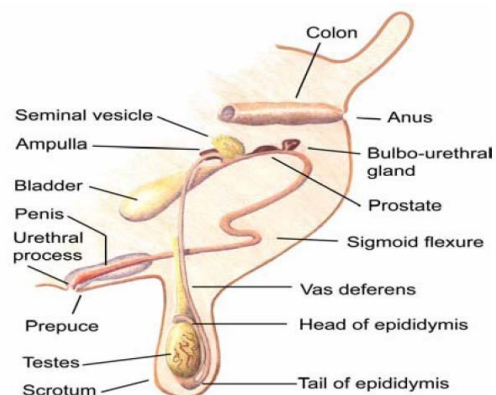

FIGURE 24: MALE REPRODUCTIVE SYSTEM

Scrotum: The scrotum is a muscular sac containing the testes. It supports and protects the testes and also plays a major role in temperature regulation. It maintains the temperature 3 to 5°C below body temperature for optimal function.

Single versus split scrotum: This could be breed-specific as in Somali goats. Some breeders consider the split scrotum as an undesirable trait and select against it. However, the important thing is to check if equal-sized testicles are present and sperm production is normal.

a. Single scrotum b. Partially split scrotum c. Split scrotum Figure 24. Single versus split scrotum.



FIGURE 25: SCROTUM TYPES

Vas deferens: The vas deferens is the duct that rises from the tail of the epididymis into the abdomen, where it joins the urethra at the neck of the bladder. It is often referred to as the ‘spermatic cord.’ Removal of a section of the vas deferens in each testis is known as a vasectomy, preventing passage of sperm from the epididymis.

Accessory sex glands: The accessory sex glands include the bulbo-urethral, prostate, and seminal vesicle

glands and the ampulla. Accessory glands secrete additional fluids, which when combined with the sperm and other secretions from the epididymis, form the semen. Some of the secretions contain nutrients like fructose while others produce alkali secretion to raise the pH of the ejaculate. These secretions are added quickly and forcibly during the mating to propel sperm into the urethra.

Penis: This is the final part of the male reproductive tract and its function is to deposit semen into the vaginal tract of the female. At the end of the penis is a narrow tube called the urethral process (or 'worm') that sprays the semen in and around the cervix of the ewe/doe. The preputial sheath protects the penis, except during mating.

EFFECT OF TEMPERATURE ON REPRODUCTION

Increased body temperature can lower the reproductive rate in ewes/does by decreasing ovulation rate, delaying heat cycles or by increasing embryonic mortality. Heat stress in males affects the process of spermatogenesis and can render bucks and rams temporarily sterile for 6 to 10 weeks. For these reasons, it is important to assist animals in maintaining body temperature, especially during times of the year when ambient temperature is high. A simple provision of shade in range production systems could reduce the negative effect of heat. Physiological mechanisms in the male assist in regulating temperature

FACTORS AFFECTING PUBERTY

Several factors such as nutrition, body weight, breed, season of birth and growth rate are known to influence the age at puberty. Nutrition is among the most significant factors influencing reproductive development and the onset of puberty.

THE ESTRUS CYCLE IN EWES AND DOES

Once puberty is reached, large domestic animals such as sheep and goats display a polyestrous (repeated reproductive cycles) pattern of reproductive activity. The estrus cycle, defined as the number of days between two consecutive periods of estrus (heat), is on average 17 days in ewes and 21 days in does

EWES

The signs of estrus in the ewe are not obvious unless a ram is present. As in the doe, the vulva is swollen and redder than usual, and there is a discharge of mucus but is difficult to see in a ewe with a tail or fleece.

All of the symptoms mentioned may not be exhibited by a doe or ewe in estrus. The best confirmation of

estrus is when the doe or ewe stands when being mounted. This is commonly called ‘*standing heat*.’ The duration of estrus is variable in that it is shorter in younger ewes and does but longer in older animals. Normal duration will be 24 to 36 hours.

MEASURES OF REPRODUCTIVE PERFORMANCE

Measures of reproduction commonly used in sheep and goats include age at puberty, age at first lambing/kidding, post-partum interval, parturition interval and fertility indices.

AGE AT PUBERTY

It is difficult to have an accurate measure of puberty unless hormonal assays are done at certain intervals (biweekly). On experimental stations, puberty may be recorded as the first behavioral estrus observed. This estrus is called pubertal estrus. The manifestation is not strong and its duration is short, hence, requiring close attention for heat detection.

AGE AT FIRST LAMBING/KIDDING

This trait can be recorded easily in a farmer’s flock. There is a big variation among production systems and breeds for this trait (12–24 months). It is usually late in animals living in harsh environments.

Ewes and does giving birth in the dry season have a longer interval compared to those lambing/kidding during the rainy season. Ovarian activity in most tropical breeds commences after weaning. Suckling interferes with hypothalamic release of GnRH, provoking a marked suspension in the pulsatile LH release, resulting in extended postnatal anestrous. Females at earlier parities take longer than older ones to return to reproductive status.

PARTURITION INTERVAL (LAMBING/KIDDING INTERVAL)

This refers to the number of days between successive parturitions. It is called lambing interval in ewes and kidding interval in does. Under normal circumstances (no drought), tropical sheep/goats should be lambing/kidding at least three times in 2 years. For this to be realized, lambing/kidding interval should not exceed 8 months (245 days). As the major component of parturition interval is post-partum interval (PPI), accelerated lambing or kidding revolves around manipulating PPI because a shorter PPI will result in a shorter parturition interval. Better nutrition and early weaning could impact this measure of reproductive performance.

Tests on an eight-month lambing interval under controlled mating in Horro sheep has shown acceptable results in both ewe and lamb performance. One of the most important ways of increasing offtake rate is through reduction of the parturition interval and, if done with optimal input, this may help in meeting the growing demand of the export trade.

FERTILITY

Various definitions of fertility exist in literature such as conception rate, fecundity, prolificacy, birth rate, etc. A general definition of fertility is the number of ewes lambing or does kidding divided by the number of ewes/does mated. Fertility is affected by factors such as nutrition, age, diseases and season of mating. In most cases, there is a positive effect of supplementation. Supplementation during the mating period (shortly before the mating period and afterwards) could increase the number of ova shed and improve embryo survival. This practice is called flushing and is discussed in the nutrition and management sections. Age of the ewe or doe is also an important factor. Fertility increases with age, and also starts to decline with old age.

LITTER SIZE (LS)

This is a combination of ovulation rate and embryo survival. Litter size (LS) varies between 1.08 and 1.75 with average of 1.38. A litter size of 1.93 has been reported in Boer goats. This is said to increase to 2.5 with selection. Sheep and goats in the pastoral areas are known to give birth to singles only. This might be due to negative selection that has taken place in the environment. Heritability estimates suggest the possibility of genetic improvement in LS through selection.

SEASONALITY OF BREEDING

Different sheep and goat breeds have developed in a wide range of environments and have consequently evolved a variety of reproductive strategies to suit these environments. Local breeds of sheep and goats in tropical conditions are either non-seasonal breeders or exhibit only a weak seasonality of reproduction. Females ovulate and exhibit estrus almost the whole year round, even though short periods of anovulation and anestrus are detected in some females. Two main hypotheses can be raised to explain the near-absence of seasonality: either the females are insensitive to photoperiod, or the amplitude of the photoperiodic changes is too small to induce seasonality.

18. SHEARING AND DAGGING (CRUTCHING)

Woolly sheep naturally lose their coats in the warmer months so before this happens we shear the sheep in order to take the wool for a variety of uses.

If the wool becomes dirty with dung and wet it attracts flies which lay eggs in the wool. The eggs develop into maggots which feed on flesh of the sheep.

Learning objectives

After studying this unit you will know:

1. Why we shear sheep.
2. What is dagging (crutching).
3. What happens if we do not dag or cheer the animal.

WHY DO WE SHEAR SHEEP?

Woolly sheep must be sheared at certain times of the year. If we do not shear them the wool or hair will be lost in patches and a valuable material will be lost.

DAGGING (CRUTCHING)

Dagging or crutching is the cutting away of dirty, wet wool from around the tail and anus (crutch) of the sheep. The wet, dirty wool attracts flies especially the blow flies (bright green or blue in color). The flies lay their eggs on the wool and in one or two days' maggots hatch from them. The maggots burrow into the skin and feed on the flesh of the sheep. The animal will be smelly, nervous, stamping its feet and wriggling its tail.

Maggots must be removed from an infected sheep. Part the wool and look for the small holes where the maggots have entered the skin. Press all-round the hole with your fingers and the maggots will come out. Many maggots of different sizes will emerge. Clean the wound with tincture of iodine or gentian violet.

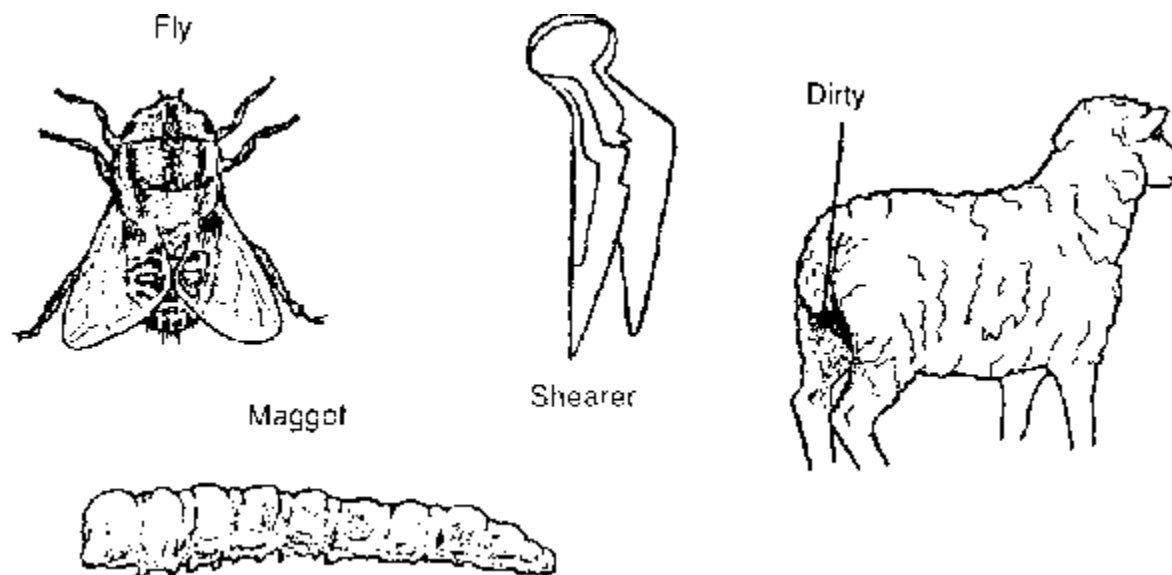
DAGGING**FIGURE 26: DAGGING****SHEARING**

Shearing is the complete removal of the wool and is carried out using machine or hand shears. The valuable wool can then be used for clothing, carpets etc. Make sure that the wool is kept clean by not using too much marker paints on the animal and if it is your custom to wash your animals before shearing make sure that you wash them three or four days before shearing. After shearing keep the sacks of wool in a dry place on plastic sheets to stop them getting damp.

If the animal is cut during shearing treat all wounds immediately with tincture of iodine or gentian violet.

If you have the means to dip your sheep do it immediately after shearing.

19. DEHORNING CALVES, LAMBS AND KIDS

Animals which have been dehorned are quiet and do not fight and cause injury to others.

The best time to remove the horns (disbudding) is when the animals are less than one week old.

Learning objectives

After studying this unit you will know:

1. Why we dehorn animals.
2. What tools we need to carry out disbudding.
3. How to dehorn animals.

WHY DO WE REMOVE THE HORNS?

Removing the horns from the animal means that:

- There is less chance of it injuring other animals.
- There is less risk of injury to people.
- An animal without horns needs less space at the feeding troughs.

The horns are best removed when still buds (buttons) on the animal which is less than one week old. This is called disbudding.

THE TOOLS USED TO DISBUD ANIMALS

To dehorn an animal you will need a dehorning iron which can be heated by electricity or over a direct flame. The end of the iron is round and hollow and will fit over the bud of the horn. *Using a hot iron is better than using caustic soda to remove the buds.*

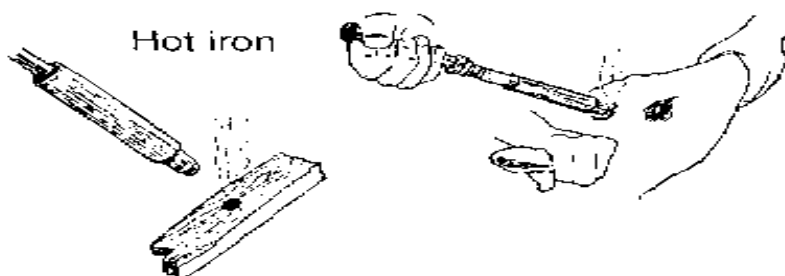

FIGURE 27: THE TOOLS USED TO DISBUD ANIMALS

You may have an iron, but if you do not, ask a blacksmith to make one for you.

To test the iron heat, it until hot and then hold the end against a block of wood. A complete, even ring should be burned into the wood. You will need to test the iron each time you use it to make sure it is hot enough.

DISBUDDING

You will need someone to help you. Take care with the hot iron.

- Restrain the animal. Your helper must hold its head and pull the ear nearest the bud you are going to remove, down and away from the bud. He must hold the head very still.
- Cut the hair away from around the bud of the horn.
- Test the hot iron and when ready put the iron over the bud and twist it around for about 10 seconds. Continue until the bud feels loose, reheating the iron if necessary.
- Push the bud out by pressing with the iron.

20. CASTRATION OF RUMINANTS

Castration is the destruction or removal of the testicles of the male. It is carried out on animals which are not wanted for breeding.

Castrated animals are quiet (do not fight).

Some countries insist on all imported animals being castrated.

Learning objectives

After studying this unit, you will know:

1. Why we castrate animals.
2. When we castrate animals.
3. The way animals are controlled for castration.
4. How to castrate with a knife.
5. How to castrate with a Burdizzo.
6. How to castrate with rubber bands.

WHY DO WE CASTRATE ANIMALS?

Traditionally farmers or animal raisers do not castrate animals and both males and females are allowed to mix together. The result is that poor males are allowed to mate with the females and the young stock produced are not very good. Uncastrated males also fight so it is better to castrate the animals which are not the best for breeding.

WHEN DO WE CASTRATE ANIMALS?

The best time to castrate animals is when they are very young (a few days old). If castration is carried out then, the operation is easier and more successful and the wound heals (gets better) very quickly.

HOLDING AND CONTROLLING ANIMALS FOR CASTRATION

You will need another person to help you. It is best to put young lambs and kids on a table covered with sacks. Calves can be castrated when they are standing but the animal must be restrained very well.

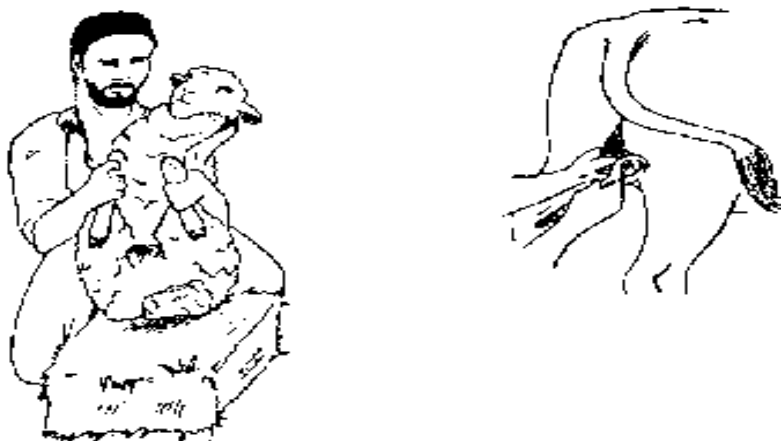

FIGURE 28: HOLDING AND CONTROLLING ANIMALS FOR CASTRATION

CASTRATION WITH A KNIFE (BLOOD)

Use a very sharp knife, razor or scalpel.

- Check that the knife, razor or scalpel is very sharp and clean. Clean the blade with a disinfectant such as alcohol, iodine, Dettol or gentian violet.
- Use warm water and soap to wipe the scrotum and wash your hands.
- Cut the bottom end of the scrotum. Squeeze the testicle above the cut end of the scrotum and it will come out.
- Pull each testicle out as far as possible, twist the testicular cord around several times. Cut the cord in cattle and buffalo by scraping the knife slowly up and down. Pull to sever the cord in lambs and kids.
- Do not put your fingers inside the open scrotum. Put either tincture of iodine, gentian violet, Dettol or antibiotic powder on the wound.

CASTRATION WITH BURDIZZO (NO BLOOD)

The Burdizzo should be used on the young animal. There are Burdizzos for animals of different sizes. You should always remember that the Burdizzo is a valuable instrument and keep it clean and oiled. Do not drop it. To castrate with the burdizzo:

- Feel the scrotum with your hand and you will feel the two rope-like testicular cords inside.
- Take the Burdizzo in your right hand and with your left hand push the cord to the side between the jaws of the Burdizzo and squeeze hard.

- Now take the Burdizzo in the left hand and crush the other cord.

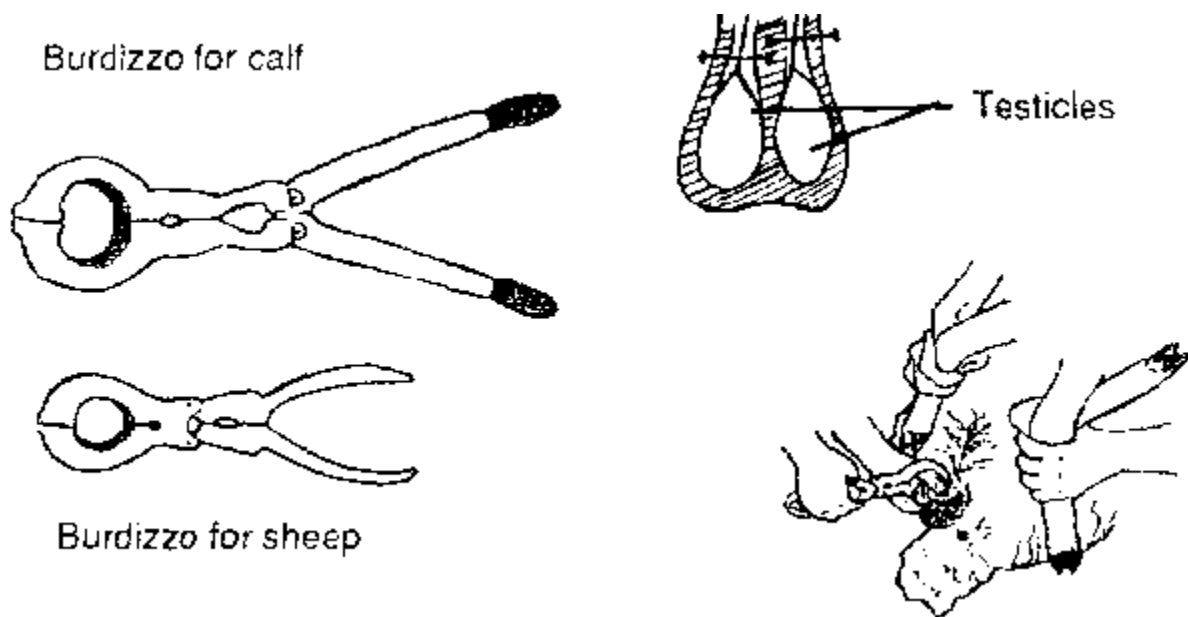

FIGURE 29: CASTRATION WITH BURDIZZO (NO BLOOD)

CASTRATION WITH RUBBER RINGS

To castrate with rubber rings, we use a tool called an elastrator. It can only be used to castrate ruminants which are a few days old.

- Put a rubber ring around the four teeth of the elastrator and squeeze the handle. The rubber ring will be stretched open.
- Pass the scrotum of the animal through the ring making sure that it goes over the two testicles.
- Release the elastrator and the rubber ring will tighten over the cords. After two weeks, the scrotum will fall off

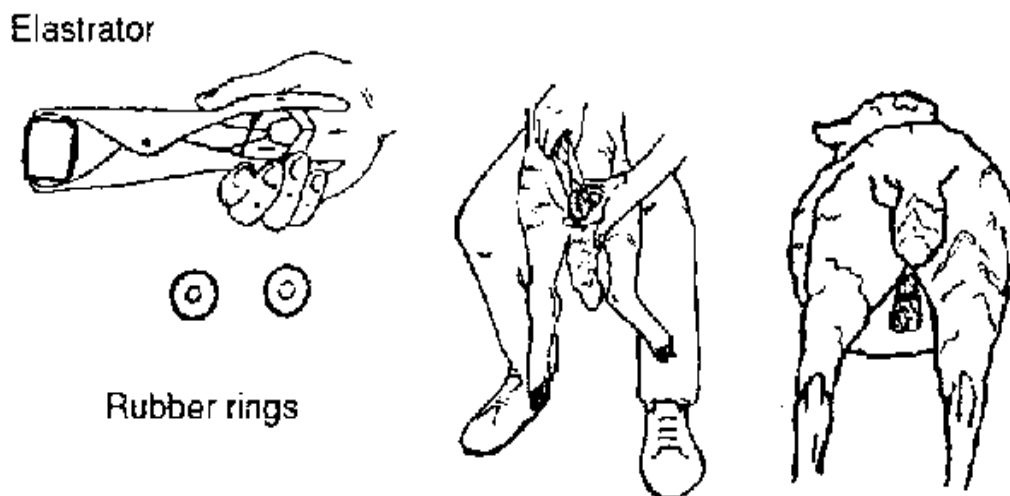

FIGURE 30: CASTRATION WITH RUBBER RINGS

Check all animals which have been recently castrated for signs of infection.

AFTERCARE NEEDED:

The following care should be taken after castration of the animals:

- Turn calves in with their mothers in a clean grass pen.
- Do not turn into muddy or filthy lots or lots around barns (where there is much danger of infection).
- Watch the animal closely for about 10 days after castration.
- Beware of fly attacks and infection (especially with emasculator method).
- Treat wounds with wound aerosol which discourages fly attacks.
- If swelling and pain are severe and/or if the animal develops fever, a suitable antibiotic should be injected

21. INTERNAL PARASITES OF RUMINANTS

Small worms can infect sheep, cattle, goats and buffalo, and live in the animal's gut, lungs, liver and blood.

These worms are called parasites and the animal they live in is called the host. The parasite feeds off the host which becomes weak, loses weight, develops disease and can die.

Learning objectives

After studying this unit you should know:

1. What is a parasite.
2. How animals become infected.
3. The problems caused by parasites.
4. How to control parasites.

WHAT IS A PARASITE?

A parasite lives in or on another animal and feeds on it. All animals and humans can become infected with parasites. Ruminants can be infected with several types of worms.

Roundworms are small, often white in color, and look like threads. Different roundworms are found in all parts of the gut and the lungs.

Tapeworms are long, and flat and look like white ribbons. They consist of many segments and live in the intestine.

Flukes are flat and leaf-like, they live in the liver. Schistosomes are small and worm-like, both infect animals kept on wet, marshy ground as their eggs develop in water.

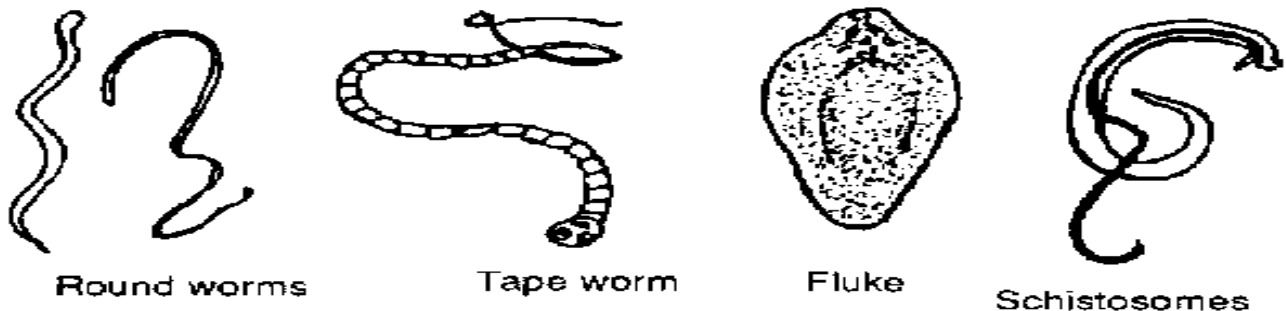

FIGURE 31: TYPES OF PARASITES

HOW DO ANIMALS BECOME INFECTED WITH PARASITES?

The roundworms, flukes and schistosomes lay eggs which pass out of the animal in the dung onto the pasture. Tapeworms produce eggs in the segments which break off and pass out in the dung. Animals become infected when they graze the pasture.



FIGURE 32: HOW DO ANIMALS BECOME INFECTED WITH PARASITES?

THE EFFECT OF PARASITES ON THE ANIMAL

Parasites feed on the food in the gut and on the blood of the host. The animal becomes weak and loses weight or does not gain weight. It can develop diarrhea, which in sheep makes the wool wet and attracts flies.

Eventually the host becomes so weak that it dies. Young animals are especially affected by parasites.

CONTROL OF PARASITES

We can control parasites by:

- Killing the worms within the body
- Reducing the chances of the animal becoming infected on pastures

The worms can be killed inside the host by giving it a drug. The drugs are given by drenching, tablets or injection. Ask your veterinarian when and how often you should treat your animals.

In order to cut down the chance of animals becoming infected:

- If possible, move stock to new pasture every one to two weeks.

- Young animals should be separated from old animals and allowed to graze fresh pasture first.
- If cattle, sheep and goats are kept in the same area, let the cattle graze the pasture before the sheep, as some worms which would infect the sheep will not infect the cattle.
- If animals are kept in an enclosure, removing the dung and disposing of it will prevent the animals picking up more worms or others becoming infected.
- Do not allow animals to graze on marshy ground or on pasture where the grass is very short.
- When animals have been treated, turn them out onto fresh pasture

DEWORMING OF CALVES:

Many Buffalo calves die due to around worm infestation. Calves should be dewormed starting from 15 days of age at 15 days' interval with piperazine. Dose should be according to body weight.

ETHNOVETERINARY TREATMENT

Leaves of nirgundi (Vitex negundo), khorpad (Aloe vera), Neem seeds, kirayat (Andrographis paniculata), akamadar (Calotrophis) are to be taken at 1 kg each. All are to be ground well by sprinkling little water and filtered and 4 liters of herbal mixture can be obtained. This has to be stored for 3 days. Then 30 ml of the extract is taken and administered for one adult sheep or goat. For younger sheep or goat less than 3 months old 10 ml has to be administered orally. For adult cattle 100 ml has to be administered.

The dewormer arrest loose motion and result in solid dung and it is free from obnoxious odor. It increases grazing efficiency of animals and they look healthy.

Talk to your local veterinarian and he will advise you about controlling and treating parasites in your area. You should tell him if young animals develop diarrhea or a harsh cough and die.

22. EXTERNAL PARASITES OF RUMINANTS

Ruminants can be infected by several parasites of the skin (external parasites) which feed on the animal's skin and blood.

The parasites cause disease, loss of weight, and can lead to death of the animal.

The parasites can also carry other infections and spread diseases from one animal to another. Some of these diseases can kill.

Learning objectives

After studying this unit you will know:

1. What parasites can be found on ruminants.
2. The problems caused by infection with the parasites.
3. How to treat and control infection with parasites

THE PARASITES

All animals and man can be hosts to parasites which live on the skin. These parasites look like insects. Mites are very small and cannot be seen without a microscope. They live and lay their eggs on the skin.

Lice (singular is louse) are big enough for you to see. Man can be infected with the head louse. Cattle, buffalo, sheep and goats can be infected with

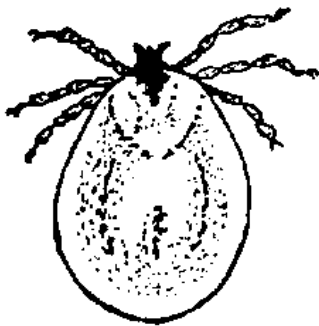

FIGURE 34: LICE

different lice which attack the body, legs or tail region. Lice live and lay their eggs on the skin amongst the hair or wool.

Ticks are bigger than lice and can be as big as a fingernail. Young ticks have 6 legs while adults have 8 legs. All ticks feed on the blood of the host and then drop off onto the pasture. They lay their eggs on the ground. Some ticks live on one host while others may live on two or three different animals throughout their lives

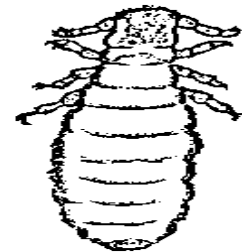

FIGURE 33: MITES

PROBLEMS CAUSED BY EXTERNAL PARASITES

Mites cause mange. They infect the head, legs, body or tail region causing the skin to become crusted and cause loss of hair and wool. The infected area itches and the animal scratches. The host does not feed well. The infections cause loss of valuable wool in sheep and damage hides of cattle and goats.

Sometimes young animals become infected with a skin disease called ringworm. Ringworm causes circular, whitish patches on the skin which do not itch. Animals can have both mange and ringworm and large areas of skin may be affected.



FIGURE 35: RINGWORM

Lice also cause irritation of the skin and the animal scratches, rubs and bites the infected areas. The host loses, or does not gain weight, and looks in poor condition. Both lice and mites can pass from one animal to another. Biting and scratching are the first signs of infection. If you examine the animal you will be able to tell if the skin problem is caused by lice or mites, if lice are on the animal you will find them in its coat, if you do not see any the animal probably has mange caused by mites.

Ticks are very important parasites. They bite the host and suck its blood and when full drop off onto the pasture where they can live for many months without feeding again. Animals can be poisoned or paralysed by the bites of some ticks. Ticks also spread diseases, tick-borne diseases, which can cause death of the host. Ticks cause the loss of meat, wool, milk and leather.

TREATMENT AND CONTROL

Mites and lice are controlled by washing the infected area, spraying or dipping the animal with a suitable treatment. All of the flock or herd must be treated to ensure control. Some animals can be infected but show

little or no sign of infection and the parasites will spread from them to other animals if they are not treated too.

If an animal has only a few ticks these can be carefully pulled off making sure the mouthparts of the tick are removed. Rubbing ticks with a cloth soaked in kerosene (paraffin) will make them drop off the host. Large numbers of ticks are treated using sprays and dips. It will be necessary to treat all of the herd or flock.

Moving animals to different pastures and resting the contaminated pasture for a length of time can help to control the ticks. Cutting the bushes and ploughing the affected area can help to control ticks. Large numbers of ticks can be found around water holes and animal shelters. Keeping poultry in these areas can help to reduce numbers of ticks as the birds will eat them.

ETHNOVETERINARY TREATMENT

Mix common salt and few camphor in castor oil or neem oil and apply over the affected area. Whole plant extract of *ghaner* (*Lantana camara*) should be diluted with the urine of cattle and apply externally. Boil 250 gm of tobacco in 2 litres of water and add 5 litres of water and sprayed over the body of 10-20 animals.

If mange or ticks are a problem in your community's livestock you should talk to your local veterinarian about it. He will advise you on the best treatment and control to use in your area. He may ask you to collect some ticks or take scrapings of skin from animals with mange so the parasite can be identified. This will help him to decide which treatment you should use.

23. SIGNS OF HEAT (OESTRUS) IN RUMINANTS

Heat or oestrus is the period when the female will accept the male and mate.

There are signs which mark oestrus in all ruminants. Recognising when the female is on heat means you will know when to put her with the male or use artificial insemination.

Learning objectives

After studying this unit you should know:

1. What is heat or oestrus.
2. Recognize when a female animal is mature and comes in heat.
3. Know what the signs of heat are in different ruminants.
4. How long oestrus lasts in different animals.

WHAT IS HEAT?

The female reproductive system consists of two ovaries and a womb. Every so often the ovaries produce very small eggs (ova). The time when this happens is called heat or oestrus.

Cattle and buffalo regularly come into heat all year round. Most sheep and goats come into heat at a particular time of the year (breeding season).

KNOWING WHEN AN ANIMAL IS IN HEAT

If you know when an animal is in heat you can introduce her to a chosen male for mating or you can arrange for her to be artificially inseminated if the service is available. You will also be able to identify animals which do not go in heat.

The best time to look for signs that the female is in heat is early morning or in the evening. Take care not to disturb the animals but just watch the animals for the signs.

SIGNS OF HEAT

Ruminants can be kept on pasture or they may be stabled or tied up for most of the time. It is therefore necessary to consider this when looking for signs of heat:

1. SIGNS OF HEAT IN FREE ANIMALS (AT PASTURE):

- Most females in heat will allow other animals to mount them.
- Cows in heat will mount one another, from the rear or from the front. However, the cow on top may not be on heat.
- The vulva becomes swollen and the area around the tail becomes wet and dirty.
- If cows sniff each other's vulva and urine they may both come into heat.
- Cows can be coming into heat if they stand resting the chin on the back of another or are seen to lick or gently butt each other.
- Restlessness and calling loudly can also mean the female is coming into heat. Goats in particular become very noisy.

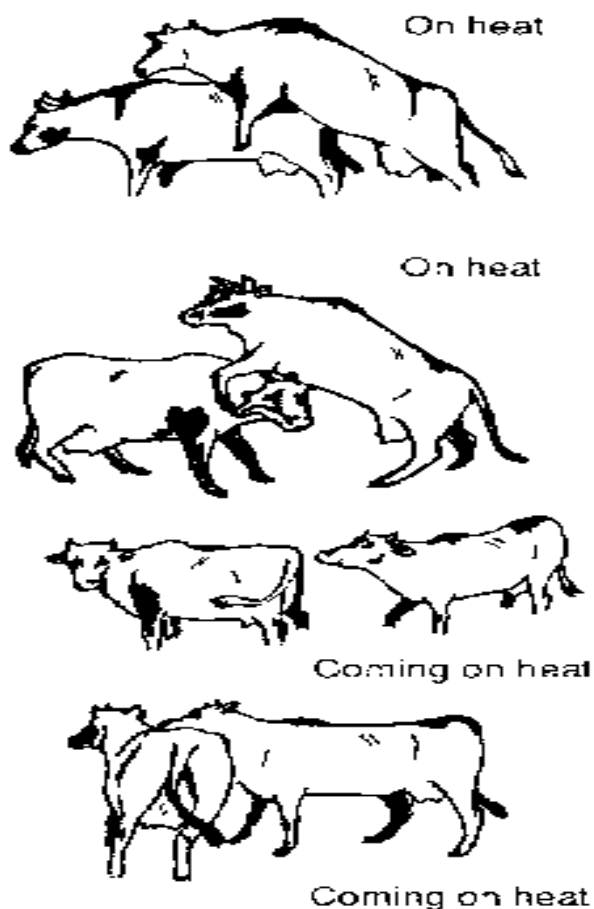

FIGURE 36: SIGNS OF HEAT IN FREE ANIMALS (AT PASTURE)

2. SIGNS OF HEAT IN THE STABLED OR TIED ANIMAL:

The animals should be allowed out twice a day when they can be watched for signs of heat. If the female is not allowed out then the following will show that she is in heat:

- Swollen vulva.
- The animal is active, there is a loss of appetite and she calls loudly.
- In milking animals the amount of milk produced suddenly drops.
- A jelly-like mucous can be found on the floor with the dung.

You will need to be able to recognize the differences between signs of heat and signs of ill health in the animal which is tied up.

WHEN DO ANIMALS COME INTO HEAT FOR THE FIRST TIME?

Animals come into heat when they reach puberty. This occurs at different ages in the different ruminants:

- Well-fed cows and buffalo come into first heat at 10 - 20 months of age.
- Sheep and goats come into first heat between 6 - 12 months of age.

HOW LONG DOES HEAT LAST?

The duration of heat is very short.

- In cows and buffalo, it lasts for less than a day.
- In goat's heat lasts for 1 - 3 days.
- In sheep heat lasts for 1 - 2 days.

A healthy animal which was not mounted by a male or given artificial insemination will come back into heat. Cattle and buffalo cows will come into heat after 3 weeks (give or take a day or two), and female goats and sheep will come back into heat after 17 days (give or take a day or two).

THE FEMALE WHICH DOES NOT COME INTO HEAT

The female may not show signs of heat because she is too old, or she may have been mated without the owner knowing. Sometimes animals come into heat without showing any signs. This is called a "silent heat" and is common in buffalo cows. If the feed is not sufficient or there is a lack of protein, salts or water, the animal can fail to come into heat. You will need to improve the female's feed to bring it into heat.

ANOESTRUS AND SUBOESTRUS CLINICAL SIGNS OF THE DISEASE

Animals not showing regular signs of heat, repeat breeding and early embryonic mortality. At times heat signs, not visible properly. Reason Nutritional deficiencies, management disorders, hormonal deficiency and uterine disorders.

Treatments for Anoestrus

1. Anainerunji (*Pedaliium murex*) 500gm is washed in 1000 ml of fermented rice water which will give an oily exudate. This is to be given orally for three days before the onset of estrous cycle. The animal may be inseminated when clear vaginal discharge is noticed.



OR

2. Rhizomes of “Ashwagandha” (*Withania somnifera*) 150gm, gingelly seeds 150 gm are to be pounded well and mixed with poultry eggs (2 numbers) and 2fruits of bananas(preferably 'Poovam' variety of bananas) to make a semisolid preparation and give it for 7 days. If does not come into heat repeat the same treatment at 7 days' interval (for 1 day only).



TREATMENTS FOR SUBOESTRUS

Bengal gram (*Cicer arietinum*) 250 gm is soaked in water for 12 hours and tied in a cloth for 24 hours for sprouting and to be given the next day morning. This is to be repeated once in two days until the animal comes to heat. Before giving this ‘Sotrukatalai’ (Aloe vera) pulp (from three sheaths after removing the spines in the sheaths) is to be given for seven days. Before insemination 100 ml of neem oil has to be administered orally. Then after insemination feed 2 handful of Curry leaves (*Murraya koenigii*) for 10 days after insemination.



24. PREGNANCY IN RUMINANTS

When the animals mate sperm from the male loins with the eggs in the womb.

Heat then finishes and the belly of the female enlarges over several months as the young grow during pregnancy.

Learning objectives

After studying this unit you should know:

1. What happens during pregnancy.
2. The signs of pregnancy.
3. Management of the pregnant animal.

WHAT IS PREGNANCY

When the male mates with the female he deposits sperm in the vagina. The sperm joins with the egg and forms the embryo which becomes attached to the wall of the womb. The embryo grows within a bag of fluid (water bag) and is attached to the wall of the womb by a navel cord.

SIGNS OF PREGNANCY

Heat stops when pregnancy begins. The animal becomes quieter and the belly grows bigger. In milk animals the production of milk will gradually drop.

LENGTH OF PREGNANCY

If male and female animals have been allowed to run together in a large herd it will be difficult to determine the expected time for birth (parturition). If however you do know when a female was mated or given artificial insemination you can determine when she will give birth. The length of pregnancy differs in different animals.

Animal	Length of pregnancy
Cow	280 days
Buffalo	320 days
Sheep	150 days
Goat	150 days

TABLE 4: LENGTH OF PREGNANCY

There can be a few days difference either way depending on the type, climate, feed and other factors.

MANAGEMENT OF THE PREGNANT ANIMAL

You must remember that a pregnant animal will need more feed and will benefit from the addition of some grain to the feed towards the end of pregnancy. All pregnant animals should be kept close to home towards the end of the pregnancy and some form of shelter should be provided. They should be watched twice a day for signs that parturition is close. In particular cattle and buffalo need a clean, well ventilated place, preferably with a sand or grit floor on which suitable bedding is placed.

Do not keep a pregnant animal constantly tied up or with little room to exercise in. Allow her some freedom in a field or yard each day. She should be observed closely twice a day for signs of parturition.

25. CALVING (PARTURITION)

Calving is a natural process which normally takes place without help. Close observation is required in case the cow has difficulties.

Cows calving for the first time (heifers) tend to have more problems than older cows and therefore need more attention when calving.

Learning objectives

After studying this unit you should be able to:

1. Know the signs of calving.
2. Recognize a normal calving.
3. Help the cow which has difficulty in calving.
4. Care for the cow immediately after calving.
5. Care for the newborn calf.

THE SIGNS OF CALVING

You will know that the cow is about to calve or give birth when you see:

- The belly has increased in size, especially on the right flank.
- The udder is filling up and the teats are stiffening.
- The vulva becomes red and swollen with the presence of mucous and blood colored fluid.
- The animal is restless
- The water bag appears at the vulva.

NORMAL CALVING

The water bag appears through the vulva. The cow will strain more. The head of the calf will appear and this breaks the bag. You will then be able to see both of the calf's front feet. It takes 4 - 6 hours for the calving to reach this stage. In heifers it might take longer. As the chest comes through the vagina the calf starts to breathe.



FIGURE 37: NORMAL CALVING

It is better to leave the cow alone to give birth naturally. However, if you want to help with the calving you can gently pull the calf by its feet. If the navel cord is still attached to the cow you can cut it with a clean sharp knife or a pair of scissors, then put tincture of iodine or alcohol on the end of the navel cord.

Sometimes the back feet of the calf appear first. You can tell the back feet from the front by looking carefully. You will see that the back feet come out from the vulva with the soles of the feet showing uppermost. You should then look (or feel with your hands) for the tail and the hock joints.

DIFFICULTIES IN CALVING

Leave the animal to give birth naturally. If difficulties occur, you may find:

1. Only the head of the calf has appeared.
2. The head and one foot has come out.
3. Two front feet showing but no head.

If this happens you should either ask the veterinarian to help or help the cow yourself

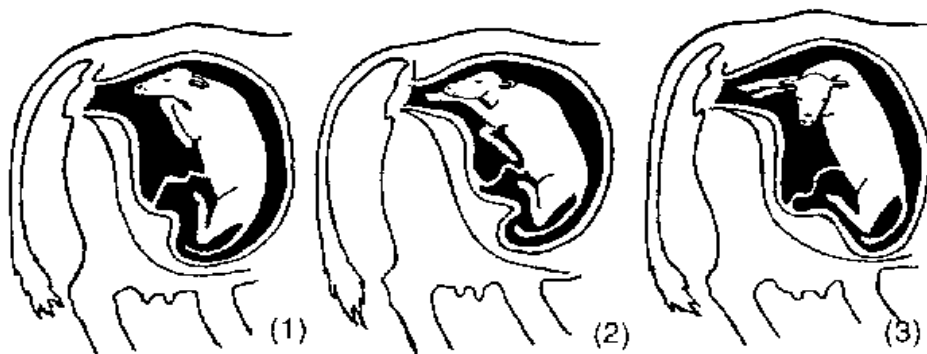
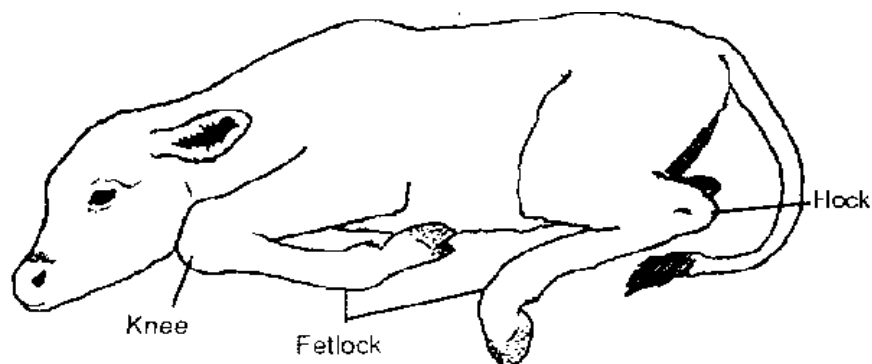

FIGURE 38: DIFFICULTIES IN CALVING

You will need a bar of soap, hot water, a clean rope and clean vegetable oil such as olive or sunflower oil. Wash the area around the vulva and wash your hands well. Make sure that your fingernails are cut short and are thoroughly clean. Long nails can injure the animal. If you have oil put some over your hand and arm, if not, soap your hand and insert it into the vagina to discover what is wrong.

You will need to recognize the difference between the front and back legs of the calf in the womb. Touch the fetlock joint and then run your hand up the leg to the next joint. There will be a knee joint on the front leg and a hock on the back leg. Push the calf either to one side or back into the uterus so that you can correct the situation and move the head and legs into the right place for birth.



When the calf's head and legs are in the correct position tie a clean rope around both feet. Pull gently on the rope. You may need someone to help you pull.

Sometimes the water bag will burst but neither the feet nor the head will have appeared. This is a very difficult position to sort out and if you can you should immediately ask your veterinarian for help.

CARING FOR THE COW AFTER CALVING

Give the cow clean water to drink immediately after she has calved as she will be thirsty.

The water bag (afterbirth) will come out naturally but you can help to remove it by gently pulling it. The afterbirth should have come away by 24 hours after the birth. If the afterbirth remains in the uterus it will cause an infection and you will need to get your veterinarian to help.

CARING FOR THE NEWBORN CALF

Always handle the calf carefully. Clean the mucous (sticky fluid) from the nose and mouth and check that the calf is breathing normally. If it is not breathing you must act immediately by:

- Pump the chest with the palm of your hand.
- Keep the calf's head lower than its back.
- Insert a straw into its nose in an attempt to make it sneeze and start breathing.

Allow the calf to suckle from its mother as soon as possible so that it takes in the colostrum, the yellowish milk which is produced immediately after birth. The colostrum is rich in protein and protects the calf against disease. Some people use the colostrum for their food but it is essential to make the calf strong and healthy and should be left for the calf.

You must allow the calf to take colostrum for at least four days after its birth

26. LAMBING AND KIDDING (PARTURITION)

Lambing and kidding, like calving, are natural processes which normally take place without help. Observation is required in case there are any difficulties.

Sheep and goats, unlike cattle and buffalo, may frequently have twins (2 young) or triplets (3 young).

SIGNS OF PARTURITION

You will know when the goat or sheep is about to give birth as:

- The animal keeps away from others.
- The vulva is swollen and the skin is loose.
- The animal becomes restless and does not eat well.
- A discharge from the vulva will start a few days before parturition.
- The sheep will lie down and stretch the neck back to look at the sky (star gazing) and lick its lips.
- The sheep will strain to push out the lamb.

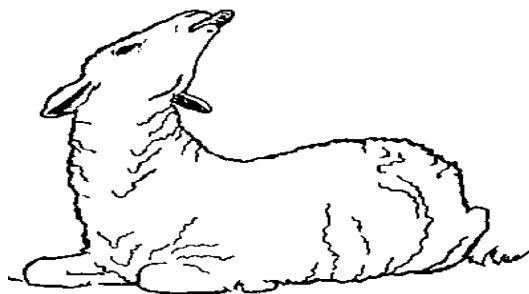

FIGURE 39: STAR GAZING

NORMAL PARTURITION

Animals may give birth while standing or lying down. The head and both front legs appear while sometimes both the hind legs will appear. The young mother may have some problems in giving birth.

WHEN AND HOW TO HELP IN PARTURITION

As with calving the young may be in an abnormal position and the birth is difficult. If you want to help you will need a bar of soap and clean water. Scrub your hands and fingernails then wash the area around the vagina. Soap your hands well and insert one hand into the vagina. When you have found what, the problem is, correct the position of the young so it can be born. Carefully feeling for the leg joints will tell you which way round the young is.

You can hold the head but do not pull the young by the jawbone as the bone will break. You can use a clean rope tied around a leg above the fetlock joint to pull. Pull in a downwards direction as the mother strains.

If there are twins or triplets in the uterus you will have difficulty sorting out which legs belong to which one. Try to pull out the one nearest the vagina first. A newborn animal should try to breathe immediately after it is born, if it does not breathe you can put a straw into a nostril (nose) to stimulate breathing. If you hold it by the back legs and swing it gently back and forth, any mucous blocking the mouth and lungs will be forced out.

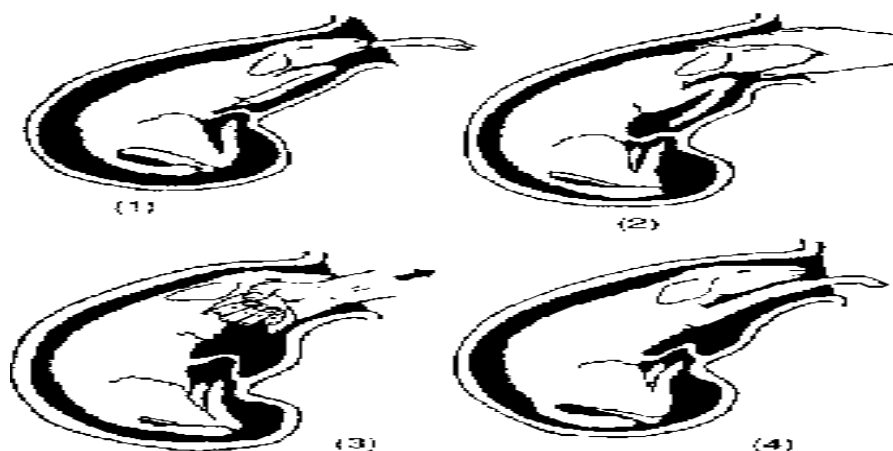

FIGURE 40: WHEN AND HOW TO HELP IN PARTURITION

CARE OF THE MOTHER AND NEWBORN

Immediately after giving birth the mother should be given fresh clean water. Check that she is producing milk from both teats and allow the newborn to suckle colostrum.

If the teats of a goat are fat with milk the young may have difficulty in suckling. Squeeze a little milk out so the kids can suckle easily. If she has produced triplets try to foster one on another mother.

If the mother had difficulty giving birth check that there are no dead young still in the uterus. If there are, remove them as they will cause an infection which will kill her.

The afterbirth should come out within 3 hours. If it has not appeared after 14 hours you will need to get veterinary help. There will be an afterbirth for each of the young the mother gave birth to.

27. CARE OF THE NEWBORN

From birth the young animal is vulnerable to disease. It is completely dependent on the mother for food and if the mother dies the orphan will need a foster mother if it is to survive.

Operations such as castration, cutting the tail and disbudding the horns must be done at a very early age to avoid unnecessary risks and least stress to the animal.

Learning objectives

After studying this unit you should be able to:

1. Check the navel cord of the newborn.
2. Check the young for extra teats.
3. Know how to foster (find new mother) for orphans (motherless young).
4. Caring for orphans.
5. Feeding the newborn.

CHECKING THE NAVEL CORD

Ideally the navel cord of the newborn animal should be dressed with tincture of iodine, gentian violet or Dettol immediately after birth. This should be repeated 2 to 3 days later. After 1 week the cord should have dried and dropped off. If infection has developed, treat it as a wound.

CHECKING FOR EXTRA TEATS

Some female ruminants are born with one or more extra teats. This is especially the case with calves.

The extra teat(s) can be removed by:

- Restrain the animal firmly.
- Identify the extra teat(s) for removal.
- Use a pair of clean, sharp scissors to cut off the teat flush with the skin.
- Dress the wound with tincture of iodine or antibiotic powder.

FOSTERING

Fostering of the young animal will be necessary if the natural mother has died or fails to produce enough milk for her young. The sheep or goat can only properly feed two young so any other young must be fostered. Fostering can be done by:

- Remove the skin of the foster mother's dead young and tie it around the orphan. After several days remove the skin.
- Rub the orphan with the afterbirth and fluids or under the tail of a mother who has just given birth. Allow the orphan to suckle with its back towards the mother's head so that she can smell it. This method is mainly used with sheep and goats.
- The foster mother can be tied up by the head in a small pen or shed and the orphan left with her. The orphan will usually suckle if the foster mother is prevented from kicking or moving away. This method can be used with sheep and goats but is also successful with cattle and buffalo. In the case of large ruminants tying a rope around the belly will stop the mother from kicking the calf as it suckles.
- Place the orphan and the foster mother in a small shed or pen and tie or leave a dog with them. The female will protect the orphan from the dog and will then allow it to suckle.

HAND REARING ORPHANS

If no foster mother is available, the orphan will need to be fed by hand. You must make sure that the orphan has colostrum, if possible for 4 days or 8 feedings. Collect the colostrum from other mothers into a clean bottle. Do not boil colostrum as it will curdle.

Lambs and kids can be fed warm milk from a bottle fitted with a rubber teat or nipple. Clean the bottle thoroughly after each feeding. They will need 4 to 6 feedings a day.

Calves can also be fed from a bottle but it is best to get them used to drinking milk from a bucket when they are a few days old. To get the calf to drink from a bucket get it to suck your fingers and then as it sucks gradually put your hand into the bucket of milk. Do this several times, holding the bucket at knee height, and the calf will feed from the bucket after a few lessons. The calf will need feeding 3 to 4 times a day. Clean and wash all bottles and buckets after each feeding.

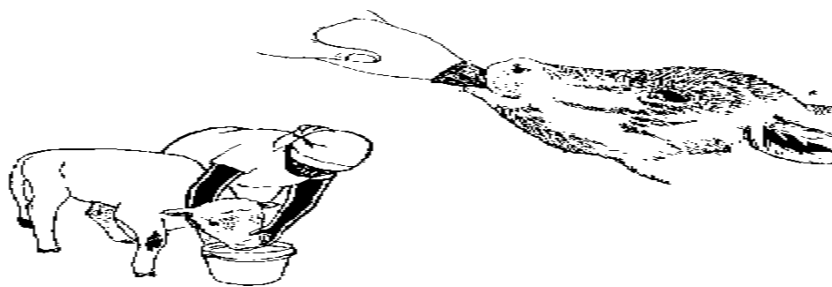

FIGURE 41: HAND REARING ORPHANS

FEEDING CALVES

The stomach of the calf needs time to develop fully and become able to digest plants. At first it can only digest milk and a 2-month-old calf will drink 4 to 6 litres of milk daily. The calf should be allowed to take all the milk it needs from his mother for the first two months of its life.

From 3 weeks of age a calf will begin to eat a little grass and by 3 months of age a calf can eat plants and ruminate. At this age the calf can be weaned. It is allowed to take less milk and is given solid food which is increased until drinking milk is stopped. It can be given grain during weaning. If the calf is left with the mother it will not be fully weaned until it is 8 to 12 months old.

FEEDING LAMBS AND KIDS

Lambs and kids will suckle from the mother until they are 4 months old, but they will start to show an interest in green plants from 3 weeks of age.

Remember that most newborn animals die because of lack of food. Cold and wet conditions are very bad for the newborn and can cause lung diseases which may kill the animal.

28. MILK PRODUCTION AND THE UDDER

The main purpose of the milk is to feed the young. A good milking animal can produce more milk than her young need.

Learning objective

After studying this unit you should know:

1. How milk is made.
2. How milk yields can be different.
3. The problems of infection (mastitis) of the udder.
4. Ways of using milk.

HOW MILK IS MADE

The udder of the cow and buffalo has four quarters, each quarter having a teat. In the sheep and goat the udder is divided into two with two teats.

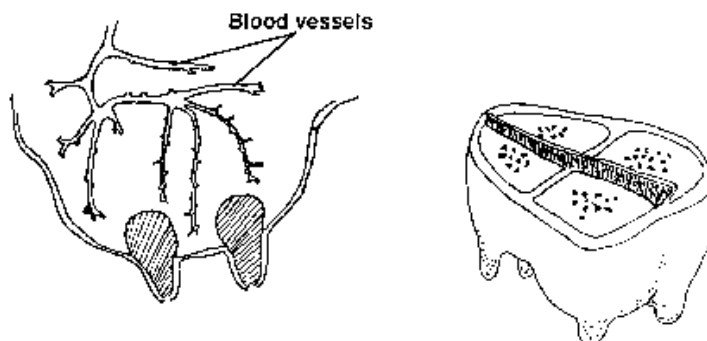

FIGURE 42: HOW MILK IS MADE

Milk is produced in the udder from nutrients in the blood which flows through the vessels (tubes) in each quarter. The greater the amount of blood passing through the udder the greater the amount of milk which is produced. The milk is released as the teat is sucked or squeezed.

Milking by hand will take from 5 to 10 minutes. The udder should be emptied at each milking and this will stimulate the udder to develop more milk. Always milk the animal quietly. A good time to milk is in the morning before the animal goes out to graze and in the evening. Always milk at the same time each day.

DIFFERENCES IN MILK YIELDS

Milk yields will vary for different reasons:

- Some types or breeds of animals produce more milk than others.
- Milk production will be greater after the birth of the second or third young.
- Extra good feed, minerals and a lot of water are needed by the animal in milk in order to produce milk.
- Milk production improves when the animal gives birth in the rainy season when there is a lot of feed available.
- Talking, singing or whistling to the sheep, cow, goat or buffalo as it is being milked makes it relax and the milk is let down better.
- Some individuals naturally give more milk than others. These individuals should be selected for breeding.

29. ECONOMIC CHARACTER IN DAIRY CATTLE

The various economic characters in Dairy Cattle management are

1. Lactation yield
2. Lactation period
3. Persistency of yield
4. Age at first calving
5. Service period
6. Dry period
7. Inter calving period
8. Reproductive efficiency
9. Efficiency of feed utilization
10. Disease resistance.

1. LACTATION YIELD

The lactation yield in a lactation period is known as lactation yield. 'The lactation yield in Indian breeds is very low compared to exotic breeds. This is dependent on no. of calving, frequency of milking, persistency of yield. Normally in dairy cattle 30 - 40 % increase in milk production from first lactation to maturity is observed. After 3 or 4 lactation, the production starts declining. For comparison of milk yield of different breeds and animals the milk yield should be converted into fat corrected milk (FCM). $4\% \text{ FCM} = 0.4 \text{ total milk} + 15 \text{ total fat}$. After parturition, the milk yield per day will be increased and reaches peak within 2-4 weeks after calving. This yield is known as peak yield. The maintenance of peak yield for more time is importance for better milk production. The lactation period in Indian breeds is low and so the production is also less and conversion.

2. LACTATION PERIOD

The length of milk producing period after calving is known as lactation period. The optimum lactation period is 305 days. The milk production will Breeding of dairy animals and farm records will be less, if this period is shortened. Indian breeds will have less lactation period, but in some breeds this period is more with very little milk production.

3. PERSISTENCY OF MILK YIELD

During lactation period the animal reaches maximum milk yield per day within 2-4 weeks which is called peak yield. For high level of lactation yield, this peak yield should be maintained for longer period as far as possible, The maintenance of peak yield for long period is known as persistency, slow decrease in dairy milk yield after reaching peak yield is necessary. High persistency is necessary to maintain high level of milk production.

4. AGE AT FIRST CALVING

The age of the animal at first calving is very important for high life time production. The desirable age at first calving in Indian breeds is 3 years, 2 years in cross breed cattle and 3 1/2 years in Buffaloes. Prolonged age at first calving will have high production in the first lactation) but the life time production will be decreased due to less no of calving. If the age at first calving is below optimum, the calves born are weak, difficulty in calving and less milk production in first lactation.

5. SERVICE PERIOD

It is the period between -date of calving and date of successful conception. The optimum service period helps the animal to recover from the stress of calving and also to get back the reproductive organs back to normal For cattle the optimum service period is 60-90 days. If the service period is too prolonged the calving interval prolonged, less no. of calving will be obtained in her life time and ultimately less life time production.' If the service period is too short, the animal will become weak and persistency of milk production is poor due to immediate pregnancy.

6. DRY PERIOD

It is the period from the date of drying (stop of milk production) to next calving. When the animal in pregnancy, before next calving. The animal should be given rest period to compensate for growth of foetus. A minimum of 2 – 2 ½ months dry period should be allowed) If the dry period is not given or too low dry period, the animals suffer from stress and in next lactation, the milk production drops substantially and also it gives weak calves. On the other hand if the dry period given is too high, it may not have that much effect on increasing milk yield in the next lactation, but it decrease the production in the present lactation.

7. INTERCALVING PERIOD

This is the -period between two successive calving. It is more, profitable to have one calf yearly in cattle and at least one calf for every 15 months in buffaloes. If the calving interval is more, the total no. of carvings in her life time will be decreased and also total life production of milk decrease.

8. REPRODUCTIVE EFFICIENCY

The reproductive efficiency means the more number of calves during life time, so that total life time production is increased, the reproduction or breeding efficiency is determined by the combined effect of hereditary and environment. Several measures of breeding efficiency like number of services per conception, calving interval, and days from first breeding to conception are useful. Reproductive efficiency has generally a low heritability value indicating that most of the variations in this trait is due to non-genetic factors. In adverse environmental conditions, the poor milk producing animals may not be much affected compared to high effect in high milk yield.

9. EFFICIENCY OF FEED UTILIZATION AND CONVERSION INTO MILK

The animal should take the feed more and utilize efficiently to convert into the milk.

10. DISEASE RESISTANCE

Indian breeds are more resistant to majority of disease compared to exotic cattle. Cross breeding helps to get this character

30. HOUSING FOR DAIRY CATTLE¹

An efficient management of cattle will be incomplete without a well-planned and adequate housing. of cattle. Improper planning in the arrangement of animal housing may result in additional labour charges and that curtail the profit of the owner. During erection of a house for dairy cattle, care should be taken to provide comfortable' accommodation for some individual cattle. No less important is the (1) proper sanitation, (1) durability, (3) arrangements for the production of clean milk under convenient and economic conditions, etc.

LOCATION OF DAIRY BUILDINGS

The points which should be considered before the erection of dairy buildings are as follows.

1. TOPOGRAPHY AND DRAINAGE

A dairy building should be at a higher elevation than the surrounding ground to offer a good slope for rainfall and drainage for the wastes of the dairy to avoid stagnation within. A leveled area requires less site preparation and thus lesser cost of building. Low lands and depressions and proximity to places of bad odor should be avoided.

2. SOIL TYPE

Fertile soil should be spared for cultivation. Foundation soils as far as possible should not be too dehydrated or desiccated. Such a soil is susceptible to considerable swelling during rainy season and exhibit numerous cracks and fissures.

3. EXPOSURE TO THE SUN AND PROTECTION FROM WIND

A dairy building should be located to a maximum exposure to the sun in the north and minimum exposure to the sun in the south and protection from prevailing strong wind currents whether hot or cold. Buildings should be placed so that direct sunlight can reach the platforms, gutters and mangers in the cattle shed. As far as possible, the long axis of the dairy barns should be set in the north-south direction to have the maximum benefit of the sun.

¹ Dr.C. Paul Princely Rajkumar , AC&RI, Madurai

4. ACCESSIBILITY

Easy accessibility to the buildings is always desirable. Situation of a cattle shed by the side of the main road preferably at a distance of about 100 meters should be aimed at.

5. DURABILITY AND ATTRACTIVENESS

It is always attractive when the buildings open up to a scenic view and add to the grandeur of the scenery. Along with this, durability of the structure is obviously an important criterion in building dairy.

6. WATER SUPPLY

Abundant supply of fresh, clean and soft water should be available at a cheap rate.

7. SURROUNDINGS

Areas infested with wild animals and dacoits should be avoided. Narrow gates, high manger curbs, loose hinges, protruding nails, smooth finished floor in the areas where the cows move and other such hazards should be eliminated.

8. LABOUR

Honest, economic and regular supply of labour is available.

9. MARKETING

Dairy buildings should only be in those areas from where the owner can sell his products profitably and regularly. He should be in a position to satisfy the needs of the farm within no time and at reasonable price.

10. ELECTRICITY

Electricity is the most important sanitary method of lighting a dairy. Since a modern dairy always handles electric equipment's which are also economical, it is desirable to have an adequate supply of electricity.

11. FACILITIES, LABOUR, FOOD

Cattle yards should be so constructed and situated in relation to feed storages, hay stacks, silo and manure pits as to affect the most efficient utilization of labour. Sufficient space per cow and well-arranged feeding mangers and resting are contributing not only to greater milk yield of cows and make the work of the operator easier also minimizes feed expenses. The relative position of the feed stores should be quite

adjacent to the cattle barn.

Noteworthy features of feed stores are given:

- Feed storages should be located at hand near the center of the cow barn.
- Milk-house should be located almost at the center of the barn.
- Centre cross-alley should be well designed with reference to feed storage, the stall area and the milk house.

TYPES OF HOUSING

The most widely prevalent practice in this country is to tie the cows with rope on a Katcha floor except some organized dairy farms belonging to government, co-operatives or military where proper housing facilities exist. It is quite easy to understand that unless cattle are providing with good housing facilities, the animals will move too far in or out of the standing space, defecating all round and even causing trampling and wasting of feed by stepping into the mangers. The animals will be exposed to extreme weather conditions all leading to bad health and lower production.

Dairy cattle may be successfully housed under a wide variety of conditions, ranging from close confinement to little restrictions except at milking time. However, two types of dairy barns are in general use at the present time.

1. The loose housing barn in combination with some type of milking barn or parlor.
2. The conventional dairy barn.

LOOSE HOUSING SYSTEM

Loose housing may be defined as a system where animals are kept loose except milking and at the time of treatment. The system is most economical. Some features of loose housing system are as follows.

- Cost of construction is significantly lower than conventional type.
- It is possible to make further expansion without change
- Facilitate easy detection of animal in heat.
- Animals feel free and therefore, proves more profitable with even minimum grazing
- Animals get optimum exercise which is extremely important for better health production.
- Over all better management can be rendered.

Cattle Shed²

The entire shed should be surrounded by a boundary wall of 5" height from three side and manger etc., on one side. The feeding area should be provided with 2 to 2 ½ feet of manger space per cow. All along the manger, there shall be 10" wide water trough to provide clean, even, available drinking water.

The water trough thus constructed will also minimize the loss of fodders during feeding. Near the manger, under the roofed house 5' wide floor should be paved with bricks having a little slope.

Beyond that, there should be open unpaved area (40'X35') surrounded by 5' wall with one gate. It is preferable that animals face north when they are eating fodder under the shade. During cold wind in winter the animals will automatically lie down to have the protection from the walls.



FIGURE 43: CATTLE SHED

Shed for calves

On one side of the main cattle shed there be fully covered shed "10'x15' to accommodate young calves. Such sheds with suitable partitioning, may also serve as calving pen under adverse climatic conditions. Beyond this covered area there should be a 20'x10' open area having boundary wall so that calves may move there freely.

In this way both calf and cattle sheds will need in all 50'x50' area for 20 adult cows and followers. If one has limited resources, he can build ordinary, Katcha/semikatcha boundary walls but feeding and water trough should be cemented ones.



FIGURE 44: SHED FOR CALVES

² AC&RI, Madurai, Dr.C. Paul Princely Rajkumar

CONVENTIONAL DAIRY BARN

The conventional dairy barns are comparatively costly and are now becoming less popular day by day. However, by this system cattle are more protected from adverse climatic condition.

The following barns are generally needed for proper housing of different classes

DAIRY STOCK IN THE FARM

- Cow houses or sheds
- Calving box
- Isolation box
- Sheds for young stocks
- Bull or bullock sheds

COW SHEDS

Cow sheds can be arranged in a single row if the numbers of cows are small. Say less than 10 or in a double row if the herd is a large one. Ordinarily, not more than 80 to 100 cows should be placed in one building. In double row housing, the stable should be so arranged that the cows face out (tails to tail system) or face in (head to head system) as preferred.

Advantages of tail to tail system

- Under the average conditions, 125 to 150 man hours of labour are required per cow per year. Study of time: Time motion studies in dairies showed that 40% of the expended time is spent in front of the cow, and 25% in other parts of the barn and the milk house, and 60% of the time is spent behind the cows. Time spent at the back of the cows is 4 times more than the time spent in front of them.
- In cleaning and milking the cows, the wide middle alley is of great advantage.
- Lesser danger of spread of diseases from animal to animal.
- Cows can always get more fresh air from outside.
- The head gowala can inspect a greater number of milkmen while milking. This is



FIGURE 45: TAIL TO TAIL SYSTEM

<p>possible because milkmen will be milking on both sides of the gowala.</p> <ul style="list-style-type: none"> Any sort of minor disease or any change in the hind quarters of the animals can be detected quickly and even automatically. 	
<p>Advantages of face to face system</p> <ul style="list-style-type: none"> Cows make a better showing for visitors when heads are together The cows feel easier to get into their stalls. Sun rays shine in the gutter where they are needed most. Feeding of cows is easier, both rows can be fed without back tracking. It is better for narrow barns. 	 <p>FIGURE 46: FACE TO FACE SYSTEM</p>

FLOOR

The inside floor of the barn should be of some impervious material which can be easily kept clean and dry and is not slippery. Paving with bricks can also serve ones purpose. Grooved cement concrete floor is still better.

The surface of the cowshed should be laid with a gradient of 1" to 1 1/4" from manger to excreta channel. An overall floor space of 65 to 70 sq.feet. Per adult cow should be satisfactory.

WALLS

The inside of the walls should have a smooth hard- finish of cement, which will not allow any lodgment of dust and moisture. Corners should be round. For plains, dwarf walls about 4 to 5 feet in height and roofs supported by masonry work or iron pillars will be best or more suitable. The open space in between supporting pillars will serve for light and air circulation.

ROOF

Roof of the barn may be of asbestos sheet or tiles. Corrugated iron sheets have the disadvantage of making extreme fluctuations in the inside temperature of the barn in different seasons. However, iron sheets with aluminum painted tops to reflect sunrays and bottoms provided with wooden insulated ceilings can also achieve the objective. A height of 8 feet at the sides and 15 feet at the ridge will be sufficient to give the

necessary air space to the cows. An adult cow requires at least about 800 cubic feet of air space under tropical conditions. To make ventilation more effective a continuous ridge ventilation is considered most desirable.

MANGER

Cement concrete continuous manger with removable partitions is the best from the point of view of durability and cleanliness. A height of 1'-4" for a high front manger and 6" to 9" for a low front manger is considered sufficient. Low front mangers are more comfortable for cattle but high front mangers prevent feed wastage. The height at the back of the manger should be kept at 2'-6" to 3". An overall width of 2' to 2 1/2' is sufficient for a good manger.

ALLEYS

The central walk should have a width of 5'-6' exclusive of gutters when cows face out, and 4'-5' when they face in. The feed alley, in case of a face out system should be 4' wide, and the central walk should show a slope of 1" from the center towards the two gutters running parallel to each other, thus forming a crown at the center.

MANURE GUTTER

The manure gutter should be wide enough to hold all dung without getting blocked, and be easy to clean/ Suitable dimensions are 2" width with a cross-fall of 1" away from standing. The gutter should have a gradient of 1" for every 10' length. This will permit a free flow of liquid excreta.

DOORS

The doors of a single range cowshed should be 5" wide with a height of 7', and for double row shed the width should not be less than 8" to 9'. All doors of the barn should lie flat against the external wall when fully open.

CALVING BOXES

Allowing cows to calve in the milking cowshed is highly undesirable and objectionable. It leads to insanitary in milk production and spread of disease like contagious abortion in the herd. Special accommodation in the form of loose-boxes enclosed from all sides with a door should be furnished to all parturient cows. It should have an area of about 100 to 150 sq.ft. With ample soft bedding, it should be provided with sufficient ventilation through windows and ridge vent.

ISOLATION BOXES

Animals suffering from infectious disease must be segregated soon from the rest of the herd. Loose boxes of about 150 sq. feet.. are very suitable for this purpose. They should be situated at some distance from the other barns. Every isolation box should be self-contained and should have separate connection to the drainage disposal system.

SHEDS FOR YOUNG STOCKS

Calves should never be accommodated with adults in the cow shed. The calf house must have provision for daylight ventilation and proper drainage. Damp and ill-drained floors cause respiratory trouble in calves to which they are susceptible. For an efficient management and housing, the young stock should be divided into three groups, viz., young calves aged up to one year bull calves, female calves. Each group should be sheltered in a separate calf house or calf shed. As far as possible the shed for the young calves should be quite close to the cow shed.

Each calf shed should have an open paddock or exercise yard. An area of 100 square feet per head for a stock of 10 calves and an increase of 50 square feet for every additional calf will make a good paddock. It is useful to classify the calves below one year into three age groups, viz., and calves below the age of 3 months, 3-6 months old calves and those over 6 months for a better allocation of the resting area. An overall covered space of:

1. 20-25 square feet per calf below the age of 3 months,
2. 25 -30 square feet per calf from the age of 3-6 months,
3. 30-40 square feet per calf from the age of 6-12 months and over, and
4. 40-45 square feet for every calf above one year, should be made available for the sheltering such climatic conditions. A suitable interior lay-out of a calf shed will be to arrange the standing space along each side of a 4 feet wide central passage having a shallow gutter along its length on both sides. Provision of water troughs inside each calf shed and exercise yard should never be neglected.

BULL OR BULLOCK SHED

Safety and ease in handling a comfortable shed protection from weather and a provision for exercise are the key points while planning accommodation for bulls or bullocks. A bull should never be kept in confinement particularly on hard floors. Such a confinement without adequate exercise leads to overgrowth of the hoofs creating difficulty in mounting and loss in the breeding power of the bull. A loose box with rough cement concrete floor about 15' by 10' in dimensions having an adequate arrangement of light and

ventilation and an entrance 4' in width and 7' in height will make a comfortable housing for a bull. The shed should have a manger and a water trough.

If possible, the arrangement should be such that water and feed can be served without actually entering the bull house. The bull should have a free access to an exercise yard provided with a strong fence or a boundary wall of about 2' in height, i.e., too high for the bull to jump over. From the bull yard, the bull should be able to view the other animals of the herd so that it does not feel isolated. The exercise yard should also communicate with a service crate via a swing gate which saves the use of an attendant to bring the bull to the service crate.

CLEANING OF ANIMAL SHEDS

The easy and quick method of cleaning animal house is with liberal use of tap water, proper lifting and disposes all of dung and used straw bedding, providing drainage, to the animal house for complete removal of liquid waste and urine. The daily removal of feed and fodder left over in the manger, reduces the fly nuisance. Periodical cleaning of water through eliminates the growth of algae, bacterial and viral contamination and thus keeps the animal healthy.

SANITATION IN DAIRY FARM

Sanitation is necessary in the dairy farm houses for eliminations of all microorganisms that are capable of causing disease in the animals. The presence of organisms in the animal shed contaminates the milk produced thus reducing its self-life, milk produced in an unclean environment is likely to transmit diseases which affect human health: Dry floorings keeps the houses dry and protects from foot injury. Similarly, the presence of flies and other insects in the dairy farm area are not only, disturbs the animals but also spreads deadly diseases to the animal's egg. Babesiosis, Theileriosis.

SANITIZERS

Sunlight is the most potent and powerful sanitizer which destroy most of the disease producing organism. Disinfection of animal sheds means making these free from disease producing bacteria and is mainly-carried out by sprinkling chemical agents such as bleaching powder, Iodine and Iodophor, sodium carbonate, Washing soda, Slaked Lime (Calcium hydroxide), Quick Lime (Calcium oxide) and phenol.

BLEACHING POWDER

This is also called calcium hypo chloride. It contains upto 39 % available chlorine which has high disinfecting activity.

IODINE AND IODOPHOR

This is commercially available as Iodophores and contains between 1 and 2 % available Iodine which is an effective germicide.

SODIUM CARBONATE

A hot 4 % solution of washing soda is a powerful disinfectant against many viruses and certain bacteria.

SLAKED LIME AND QUICK LIME

White washing with these agents makes the walls of the sheds and the water troughs free from bacteria.

PHENOL

Phenol or carbolic acid is very disinfectants which destroy bacteria as well as fungus.

INSECTICIDE

Insecticides are the substances or preparations used for killing insects. In dairy farms, ticks usually hide in cracks and crevices of the walls and mangers. Smaller quantities of insecticide solutions are required for spraying. Liquid insecticides can be applied with a powerful sprayer, hand sprayer, a sponge or brush; commonly used insecticides are DDT, Gramaxane wettable powders, malathion, Sevin 50 % emulsifying concentration solutions. These are highly poisonous and need to be handled carefully and should not come in contact with food material, drinking, water, milk etc.

PRECAUTIONS WHILE USING DISINFECTION IN INSECTICIDE.

- Remove dung and used bedding completely.
- Avoid spilling of dung and used bedding while carrying it out.
- Avoid the use of dirty water in cleaning the sheds.
- Never put the fresh fodder over: the previous day's left over fodder in the manger.
- Prevent algae to grow in the water troughs
- Use proper concentration of disinfectant / insecticide solutions to avoid any toxic effects poisoning.
- Avoid of the mat the milking time as milk absorbs these quickly.

PROCEDURE

- Remove the dung from the floor and urine channel with the help of a shovel and basket (iron) and transfer it to the wheel - barrow.

- Remove the used bedding and leftovers from the mangers in a similar way.
- Empty the water trough and scrape its sides and bottom with the help of a floor brush.
- Wash the water trough with clean water and white wash it with the help of lime mixture once a week.
- Scrape the floor with a brush and broom and wash with water.
- Clean and disinfect the splashes of dung on the side walls, railing and stanchions.
- Remove the cobwebs periodically with the help of a wall brush.
- Sprinkle one of the available disinfecting agents in the following concentration. Bleaching powder should have more than 30% available chlorine. Phenol 1-2% solution. Washing Soda (4% solution).
- Allow adequate sunlight to enter in to the shed.
- Spray insecticides at regular intervals especially during the rainy season (Fly season).
- Whitewash the walls periodically by mixing insecticides in it to eliminate ticks and mites living in cracks and crevices.

OTHER PROVISIONS

The animal sheds should have proper facilities for milking barns, calf pens, calving pens and arrangement for store rooms etc. In each shed, there should be arrangement for feeding manger, drinking area and loafing area. The shed may be cemented or brick paved, but in any case, it should be easy to clean. The floor should be rough, so that animals will not slip. The drains in the shed should be shallow and preferably covered with removable tiles. The drain should have a gradient of 1" for every 10" length. The roof may be of corrugated cement sheet, asbestos or brick and rafters. Cement concrete roofing is too expensive. Inside the open unpaved area it is always desirable to plant some good shady trees for excellent protection against direct cold winds in winter and to keep cool in summer.

31. ARTIFICIAL INSEMINATION³

INTRODUCTION

Artificial insemination is the technique in which semen with living sperms is collected from the male and introduced into female reproductive tract at proper time with the help of instruments. This has been found to result in a normal offspring. In this process, the semen is inseminated into the female by placing a portion of it either in a collected or diluted form into the cervix or uterus by mechanical methods at the proper time and under most hygienic conditions. The first scientific research in artificial insemination of domestic animals was performed on dogs in 1780 by the Italian scientist, Lazanno Spalbanzani. His experiments proved that the fertilizing power reside in the spermatozoa and not in the liquid portion of semen. Few further studies under research station conditions helped this technique to be used commercially all over the world including India.

Artificial insemination is not merely a novel method of bringing about impregnation in females. Instead, it is a powerful tool mostly employed for livestock improvement. In artificial insemination, the germplasm of the bulls of superior quality can be effectively utilized with the least regard for their location in faraway places. By adoption of artificial insemination, there would be considerable reduction in both genital and non-genital diseases in the farm stock.

SYMPTOMS OF HEAT

The various symptoms of heat are

- The animal will be excited condition. The animal will be in restlessness and nervousness.
- The animal will be bellow frequency.
- The animal will reduce the intake of feed.
- Peculiar movement of limbo sacral region will b observed.
- The animals which are in heat will lick other animals and smelling other animals.
- The animals will try to mount other animals
- The animals will standstill when another animal try to mount. This period is known as standing heat. This extends 14-16 hours.
- Frequent maturation (urination) will be observed.

³ (Source: <http://bieap.gov.in/DairyAnimalManagementTheory.pdf>)

- Clear mucous discharge will be seen from the vulva, sometimes it will be string like the mucous will be seen stick to the near the pasts of valva.
- Swelling of the valva will be seen.
- 11 Congestion and hyperemia of membrane.
- The tail will be in raised position.
- Milk production will be slightly decreased
- On Palpation uterus, will be turgid and the cervix will be opened.

A.I. ADVANTAGES – DISADVANTAGES

Artificial insemination (A.I.) is deposition of semen into the female genital tract by means of instruments.

ADVANTAGES OF ARTIFICIAL INSEMINATION:

There are several advantages by artificial insemination over natural mating or servicing.

- There is no need of maintenance of breeding bull for a herd; hence the cost of maintenance of breeding bull is saved.
- It prevents the spread of certain diseases and sterility due to genital diseases': contagious abortion, vibriosis.
- By regular examination of semen after collection and frequent checking on fertility make early detection of inferior males and better breeding efficiency is ensured.
- The progeny testing can be done at an early age.
- The semen of a desired size can be used even after the death of that particular sire.
- The semen collected can be taken to the urban areas or rural areas for insemination.
- 7 It makes possible the mating of animals with great differences in size without injury to either of the animal.
- It is helpful to inseminate the animals that are refuse to stands or accept the male at the time of oestrus.
- It helps in maintaining the accurate breeding and cawing records.
- It increases the rate of conception.
- It helps in better record keeping.
- Old, heavy and injured sires can be used.

DISADVANTAGES OF A.I:

- Requires well-trained operations and special equipment.
- Requires more time than natural services.
- Necessitates the knowledge of the structure and function of reproduction on the part of operator.
- Improper cleaning of instruments and in sanitary conditions may lead to lower fertility.
- If the bull is not properly tested, the spreading of genital diseases will be increased.
- Market for bulls will be reduced, while that for superior bull is increased.

SEMEN COLLECTION METHODS AND EVALUATION:

Various methods of collection of semen have been devised from time to time. The older unsatisfactory methods have gradually replaced by the new modern techniques.

There are three common methods.

1. Use of artificial vagina
2. By Electro-stimulation method.
3. By massaging the ampulae of the duct us differences through rectal wall.
4. The ideal method of semen collection is use of artificial vagina which is safe for sire and the collector also.

ARTIFICIAL VAGINA METHOD

The artificial vagina has the following parts:

- A heavy hard rubber 2" lose, open at both ends with a nostle for air and water in and outlet.
- Inner sleeve of rubber or rubber liner.
- The semen receiving cone or rubber cone.
- Semen collection tube made of glass or plastic graduate in cc and its fraction correct to 0.1 CC
- Insulating bag Before using for semen collection all the parts are washed thoroughly and sterilized properly, and assembled as artificial vagina, the rubber liner is inserted into the hose; inverting both ends back by folding back from either side opening, and fastening with rubber bands. Now the space between the hard rubber hose and inner rubber liner forms a water tight compartment. The nostle at one end of the hose can be fixed.

PARTS OF ARTIFICIAL VAGINA

Turning through the threaded nut up or down. The water jacket of the Artificial -vagina is- filled with hot water at a temperature of 45°C (113°F) by opening the nostle. The graduated semen collection tube is fixed to the narrow end of the artificial vagina hose, and fastened by a rubber band. The inner side of the rubber liner on the anterior side of the artificial vagina is lubricated with sterile jelly to a length of 3 to 4 inches. Air is blown through the nostle into the water jacket, to create pressure in if, and the same is exerted the rubber linear, to simulate natural vagina.

The temperature of the artificial vagina is to be checked, at each collection, and it should simulate natural vagina at mounting time. If the artificial vagina is to mount later. If it is too cold ejaculate may not be there after a thrust, or even if ejaculate is there; it may be contaminated with urine, and becomes unfit for use.

SEMEN COLLECTION METHOD. (A.V.)

The cow or dummy is secured in service create. The artificial vagina assembled is held at 45° angle from the direction of penis, and the thrust is that angle. The artificial vagina is held with the left hand by a right-handed person; and when the bull mounts the cow, the sheath of the bull will be graphed by the operator, directing the gland penis into the artificial vagina, and then the bull gives a thrust to ejaculate.

The operator should evince care so as not to touch the exposed past of the penis. After the bull dismounts, the artificial vagina is taken off from penis and the air vent is opened to release the pressure from the jacket.

The water from the jacket is also drained by opening the nostle. This allows the ejaculate to flow from the cone to the semen collection tube. The semen collection tube is detached from the cone, plugged with cotton wool, and taken to the laboratory for examination. The rubber cone and the semen collection tube can be protected from external contamination or heat or higher, by covering with an insulation bag with zip.



FIGURE 47: SEMEN COLLECTION

SEMEN STORAGE

The discovery that bull semen could be successfully frozen and stored for indefinite periods has revolutionized AI in cattle. In 1949, British scientists discovered that addition of glycerol to the semen extender improved resistance of sperm to freezing. Glycerol acts to remove water from the sperm cell prior to freezing and prevents the formation of cellular ice crystals which would damage the sperm. There are two methods of freezing and storing semen: dry ice and alcohol (-100 degrees F) and liquid nitrogen (-320 degrees F). Liquid nitrogen is preferred because there is no evidence of fertility deterioration with age. Fertility gradually declines in semen stored in dry ice-alcohol.

Frozen semen can be stored indefinitely if proper temperature is maintained. A recent report told of a calf born from frozen semen stored for 16 years. Fresh, liquid semen can be successfully stored for 1 to 4 days at 40 degrees F. Semen is usually stored in glass ampoules. Other methods appear promising, particularly the French-straw. Several AI organizations have gone to this method exclusively. Artificial coloring is frequently added to semen extenders in order to distinguish one breed from another. Complete identification of the bull is required on each individual semen container.

INSEMINATION METHODS

There are different methods of insemination in different species of animals i.e. speculum method, vaginal method and recto vaginal method.

RECTO VAGINAL METHOD

In cattle the safe and best method of insemination is “Recto vaginal method of insemination”. A cow which is in heat is well controlled by placing it in a Travis. The inseminator will get ready by wearing a plastic apron, gumboots and gloves. The semen straw after thawing (keeping the semen straw in warm water for a minute to convert the frozen semen into liquid and the sperms become motile) is loaded in a sterilized A.I. gum and is covered with a plastic sheath. The inseminator will insert the gloved left hand into the rectum after applying the soft soap or other lubricant on the glove and back rack the animal, and the hand is further inserted and will catch hold the cervix through rectal wall. The A.I gum loaded with semen straw is passed.



FIGURE 48: RECTO VAGINAL METHOD

RECTO-VAGINAL METHOD OF INSEMINATION

Through the vulva to 'vagina and cervix and observed with the hand in rectum that the A. I gum reaches the cervix, then the semen is deposited by injecting the gun, and after depositing the semen the gun is removed, the empty straw and sheath are disordered.

SPECTRUM METHOD

In this method spectrum is placed in the vagina of the cow, which provides passage outside to the site of insemination, then inseminating tube is passed through the speculum and semen is deposited at the cervix insemination method.

VAGINAL METHOD

Hand is passed through the vagina and the inseminating tube is guided by hand to the site of insemination and semen is deposited. Here there is a risk of contamination and injury of female genitalia.

FROZEN SEMEN AND STORAGE

Freezing of semen for successful preservation of spermatozoa, for long periods, is of great importance in livestock breeding and farm management. It has made it possible to make available the use of outstanding proven sires for larger number of cows, covering larger area, frozen semen shipment has become possible to different continents in the globe to any place connected with any service. Now a day if farmer wants to use of an outstanding sire for inheritance of high milk yield, he can go in for frozen semen service provided his area is, covered by Artificial insemination, with supply of frozen semen.

At present frozen semen is used in most of the states in India. The technique of semen preservation in straws was developed in France. Freezing of semen is done with a special diluent, which has the following composition. Sodium citrate dihydrate (angular) 2.4 g. 2.0 gm 8.0 ml 25.0% by volume 50,000 units per 100 ml of semen Fructose Glycerol Egg Yolk Penicillin diluent. Dihydro-streptomycin 50.0 mg per .100ml of semen diluent. Distilled water double glass distilled 100.0ml. The addition of glycerol to the diluent makes the cells more resistant to the rigours of freezing and icy crystals, which form are smaller and smoother thus creating less damage to the spermatozoa. The addition of fructose to the diluent improves sperm resistance to glycerol; and also provides nutrition.

Frozen semen is packed in single dose glass vials or plastic straws at +5°C. The final level of glycerol should be 7.0 to 7.6% during the freezing process. The antibiotics are added to inhibit bacteria and to kill pathogenic organisms. The semen to be diluted in such a way that one ml. of extended semen will contain 20

million motile spermatozoa. The semen must be cooled carefully for spermatozoa to remain with life. The final temperature is lowered to -79°C or still lower. Quick freezing is done for a period of 3 to 5 minutes to -75°C with the help of atmosphere created by liquid nitrogen. In the slow freezing technique cooling is done at the rate of 1°C per minute from $+5^{\circ}\text{C}$ to -15°C . From -15°C to -31°C at the rate of 2°C per minute. From -31°C to -75°C at the rate of 4 to 5°C per minute. Thus, taking 40 minutes in total, further cooling to -96°C can be done quickly as it is not critical after freezing. Before freezing the diluted semen in equilibrated for 3 to 5 hours or for the best 16 to 20, hours period in refrigerator at 5°C . Frozen semen facilitates the percent use of the semen diluted and frozen, and thus the delivery price is reduced, and it can be supplied with the gaps of months to the A.I technicians as against the supply of fluid semen every days or alternate days. Liquid nitrogen plays a vital role for storing the frozen semen straws, at a temperature of -196°C for longer periods.

ARTIFICIAL INSEMINATION (AI) OF CATTLE

Artificial insemination (AI) is the process of collecting sperm cells from a male animal and manually depositing them into the reproductive tract of a female. One can cite a number of potential benefits from the use of artificial insemination.

INCREASED EFFICIENCY OF BULL USAGE

During natural breeding, a male will deposit much more semen than is theoretically needed to produce a pregnancy. In addition, natural breeding is physically stressful. Both of these factors limit the number of natural mating a male can make. However, collected semen can be diluted and extended to create hundreds of doses from a single ejaculate. Also, semen can be easily transported; allowing multiple females in different geographical locations to be inseminated simultaneously, and semen can be stored for long periods of time, meaning that males can produce offspring long after their natural reproductive lives end.

INCREASED POTENTIAL FOR GENETIC SELECTION

Because artificial insemination allows males to produce more offspring, fewer males are needed. Therefore, one can choose only the few best males for use as parents, increasing the selection intensity. Furthermore, because males can have more offspring, their offspring can be used in a progeny test program to more accurately evaluate the genetic value of the male. Finally, individual farmers can use artificial insemination to increase the genetic pool with which his or her animals can be mated, potentially decreasing effects of inbreeding.

DECREASED COSTS

Male animals often grow to be larger than females and can consume relatively larger amounts of feed. Also, male animals are often more strong, powerful, and potentially ill-mannered and thus require special housing and handling equipment.

INCREASED SAFETY FOR ANIMALS AND FARMERS

As mentioned, male animals can become large and aggressive. These factors mean that maintaining a bull on a farm may be dangerous. Also, because of the relatively larger size of adult males than females, natural mating is more likely to result accidents and injury to either the cow or the bull than is artificial insemination.

⁴REDUCED DISEASE TRANSMISSION

Natural mating allows for the transfer of venereal diseases between males and females. Some pathogens can be transmitted in semen through artificial insemination, but the collection process allows for the screening of disease agents. Collected semen is also routinely checked for quality, which can help avoid problems associated with male infertility.

Artificial insemination has some potential drawbacks, however, that must be considered. First, it can be more laborious. Male animals instinctively detect the females that are in the correct status for conception. With artificial insemination, the detection work falls on the responsibility of the farmer. Poor detection results in decreased rates of fertility. Also, increasing the number of offspring per male has selective advantages only if the best males can be accurately determined. Otherwise this process only decreases the genetic variability in a population. Increasing the number of offspring per male always reduces the gene pool. The benefits of more intense selection must be balanced against the negative effects of decreased variation.

ARTIFICIAL INSEMINATION TECHNIQUES

The technique of inseminating a cow is a skill requiring adequate knowledge, experience and patience. Improper AI techniques can negate all other efforts to obtain conception. Semen must be deposited within the tract of the cow at the best location and at the best time to obtain acceptable conception rates. Early methods of AI involved deposition of the semen in the vagina, as would occur in natural mating. Those methods are not satisfactory. Fertility is low and greater numbers of sperm are required. Another method

⁴ (*Source:* www.naweb.iaea.org)

which gained popularity was the "speculum" method. This method is easily learned, but proper cleaning and sterilizing of the equipment is necessary, making it more impractical to inseminate than with the rectovaginal technique which is the most widely used AI method today. In the recto-vaginal technique a sterile, disposable catheter containing the thawed semen is inserted into the vagina and then guided into the cervix by means of a gloved hand in the rectum. The inseminating catheter is passed through the spiral folds of the cow's cervix into the uterus. Part of the semen is deposited just inside the uterus and the remainder in the cervix as the catheter is withdrawn. Expulsion of the semen should be accomplished slowly and deliberately to avoid excessive sperm losses in the catheter. The body of the uterus is short; therefore, care should be taken not to penetrate too deeply which might cause physical injury. In animals, previously inseminated, the catheter should not be forced through the cervix since pregnancy is a possibility. Since research data show little variation in conception rates when semen is placed in the cervix, uterine body or uterine horns, some people recommend incomplete penetration of the cervical canal and deposition of semen in the cervix.

The recto-vaginal technique is more difficult to learn and practice is essential for acceptable proficiency but the advantages make this method of insemination more desirable than other known methods. With practice, the skillful technician soon learns to thread the cervix over the catheter with ease. If disposable catheters are used and proper sanitation measures are followed, there is little chance of infection being carried from one cow to another.

TIMING OF INSEMINATION FOR MAXIMUM CONCEPTION

A frequent question concerning AI is: What time during estrus should cows be bred for greatest chance of conception? Since estrus may last from 10 to 25 hours there is considerable latitude in possible time of insemination. Much research work has been conducted on this subject.

Controlled investigations were conducted by Trim Berger and Davis at Nebraska in 1943. These and other studies show that conception rate is lower when cows are bred prior to mid estrus or later than 6 hours after cessation of estrus (standing heat in this case). Maximal conception is obtained when cows are inseminated between mid-estrus and the end of standing estrus, with good results up to 6 hours after estrus. Success in insemination timing is dependent upon a good heat detection program. In large herds, this means assigning individual responsibility for heat detection and a continued education program for labor. A successful heat detection program and subsequent proper timing of insemination will pay dividends in increasing reproductive efficiency.

Cows showing estrus	Should be inseminated	Too late for good results
In morning	Same day	Next day
In afternoon	Morning of next day or early afternoon	After 3 p.m.

TABLE 5: A PRACTICAL RECOMMENDATION FOR TIMING OF INSEMINATION

32. INFECTION OF THE UDDER (MASTITIS)

A good udder is essential for milk production. If the udder is injured or infected milk production can stop.

Infection of the udder is called mastitis and is caused by germs. Mastitis can be recognized by:

- The milk is not clean; the color is different and there may be lumps in the milk
- The udder is hot, painful and swollen.
- The skin of the teats is cracked.
- The animal may stop eating.

More than one quarter of the udder may be infected. The mastitis may be caused by a germ which is infectious and spreads to other animals. Goat milk must be closely looked at for signs of mastitis because the milk may not show a noticeable change in color.

To stop mastitis or to reduce the chances of it occurring the following steps should be taken:

- The hands of the milker should always be clean.
- The udder should be washed with warm water and dried before the animal is milked.
- Any animal with mastitis (or other disease) should always be milked last.
- Treatment of mastitis will be successful if it is started early.

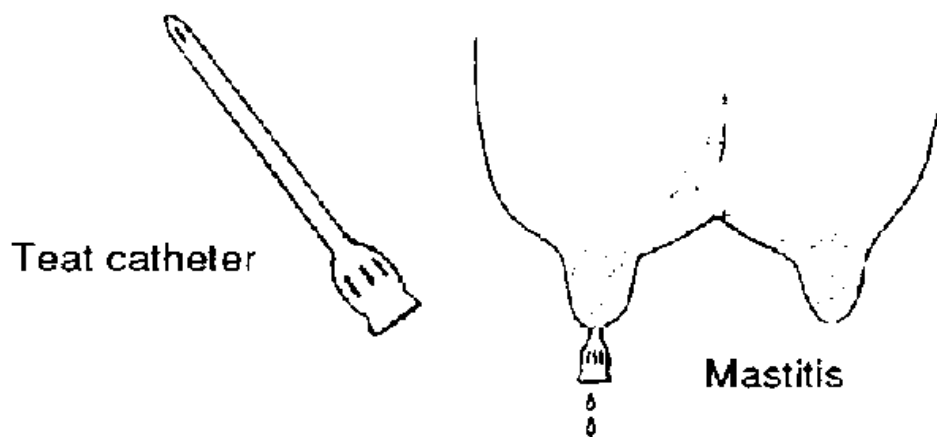

FIGURE 49: INFECTION OF THE UDDER (MASTITIS)

To treat mastitis the udder should be bathed with warm water. The bad milk in the udder should then be removed using a clean teat catheter or by hand milking. This is carried out at least twice a day until the udder returns to normal.

A treatment which is now preferred is to bathe the affected quarter with cold water and then milk out the quarter. The udder is then dried and massaged. This is repeated morning and night until the udder returns to normal. If the infection is severe this treatment is repeated every 2 to 3 hours.

If the infection persists antibiotic in a tube should be squeezed into the teat canal following each milking. You can give an injection of antibiotic in cases of severe mastitis.

Ask for veterinary advice if mastitis is a continual or spreading problem in your community.

PRINCIPLES OF FEEDING

1. Green grasses with legumes provides both carbohydrates and proteins, with 3:1 ratio, in order to have a balanced ration
2. Green fodder also supplements vitamins, minerals and trace elements.
3. Feed the fodder both green and dry, by chaffing to avoid wastage
4. Tree fodder are perennial source for green leaves and pods
5. Quantity of dry and green fodder 5kgs and 20 kgs respectively in cattle
6. Concentrate feed should be prepared to take care of pregnant, growing, milking animals in order to meet their nutritional requirements
7. Green fodder should be harvested at 50% flowering stage.
8. Surplus green fodder should be conserved in the form of 'hay' or 'silage'
9. Conserved fodder becomes useful during summers or when green fodder is scarce.

TYPES OF FEED

- **Roughage** is bulky and low in energy-giving carbohydrates. Examples of such feeds are grasses, maize stalks and sweet potato tops.
- **Concentrates** are feeds which are rich in proteins and carbohydrates, e.g. grain crops.

WHAT AN ANIMAL NEEDS IN ITS FEED

All animals and humans need the nutrients called carbohydrates, proteins, fats, vitamins and minerals in their feed in order to stay healthy, have energy, grow and reproduce.

Carbohydrates such as sugar and starch are burned in the body to give energy. Fats are broken down in the body to give carbohydrates and water. Animals and humans store carbohydrates as fat in the body.

Protein forms the building blocks of the body. It is needed to produce the muscles.

Minerals such as copper and calcium are needed to form the bones, brain, nerves and blood. Plants take in minerals from the soil. **Vitamins** are essential for a healthy body and all plants contain several vitamins.



FIGURE 50: FODDER CHAFFING & FODDER STORAGE -HAY



FIGURE 51: SILAGE MAKING

33. FEED AND WATER FOR RUMINANTS

In order to get the most out of livestock you must always give animals enough good feed and clean water.

Good feed is high in nutrients and provides everything that the body needs in order for the animal to grow and reproduce.

Learning objectives

After studying this unit you will know:

1. What nutrients animals need in their feed.
2. What is a daily ration?
3. What are roughage and concentrate feeds
4. Feed for the dry season
5. Fodder trees.

WHAT AN ANIMAL NEEDS IN ITS FEED

All animals and humans need the nutrients called carbohydrates, proteins, fats, vitamins and minerals in their feed in order to stay healthy, have energy, grow and reproduce.

Carbohydrates such as sugar and starch are burned in the body to give energy. Fats are broken down in the body to give carbohydrates and water. Animals and humans store carbohydrates as fat in the body.

Protein forms the building blocks of the body. It is needed to produce the muscles.

Minerals such as copper and calcium are needed to form the bones, brain, nerves and blood. Plants take in minerals from the soil. Vitamins are essential for a healthy body and all plants contain several vitamins.

If animals do not get enough of any nutrient they will become less productive and may die from a condition called a deficiency disease.

If an animal does not get enough fat, protein or carbohydrate in its feed it cannot grow properly, loses weight, milk production drops and production of young is affected. Lack of minerals results in such problems as failing to come into heat, poor bone growth and loss of hair or wool. While lack of essential vitamins can cause problems such as blindness and swollen joints.

TYPES OF FEED

A good, rich feed contains more energy than a poor feed and a cow gets as much energy from 1 kg of sorghum, barley or corn as it does from 6 kg of grass. Some feeds are very poor and of little use to the animal. For example, old straw contains little energy, most of it cannot be digested and passes out of the animal as dung.

- Roughage is bulky and low in energy-giving carbohydrates. Examples of such feeds are grasses, maize stalks and sweet potato tops.
- Concentrates are feeds which are rich in proteins and carbohydrates, e.g. grain crops.

The large stomach of the ruminant with its four compartments means that it can live mainly on roughage. Animals with single stomachs need more concentrates than ruminants.

RATIONS

A daily ration is the amount of feed an animal needs every day. A good ration will contain all of the nutrients. Some nutrients are found in large amounts in some plants:

Nutrient	Plants
Carbohydrate	maize, sorghum, wheat, oats, rice, grass
Protein	lucerne (alfalfa), clovers, beans, grass
Fats	cotton seed, sunflower seeds, grass, groundnuts

TABLE 6: DAILY RATION FOR ANIMALS

An example of a good ration which can be given to animals not on pasture is 3 parts of maize, part sunflowers and 1 part unshelled groundnuts. The ration is fed at the rate of 2 - 3% of body weight each day.

Green growing grass contains all the nutrients but in the dry season grass contains little protein and vitamins. It is necessary to give additional feeds at this time in order to prevent weight loss, maintain high milk production, growth and reproduction. It may also become necessary to give minerals to the animal.

FEED FOR THE DRY SEASON

In the dry season grass becomes scarce and is low in nutrients. When grass is plentiful in the wet growing season you can cut grass, and store it until it is needed in the dry season. The grass can be kept as hay or silage.

Hay is dried grasses. The best hay is prepared from young grasses. Cut the grass and leave it to dry in the sun for several days turning it over to make sure it is completely dry when it can be stored until needed. Do not try to make hay in the rainy season.

Silage is grass or other plants which are cut while green and stored without air. To make silage you will need an airtight container or pit to store it in.

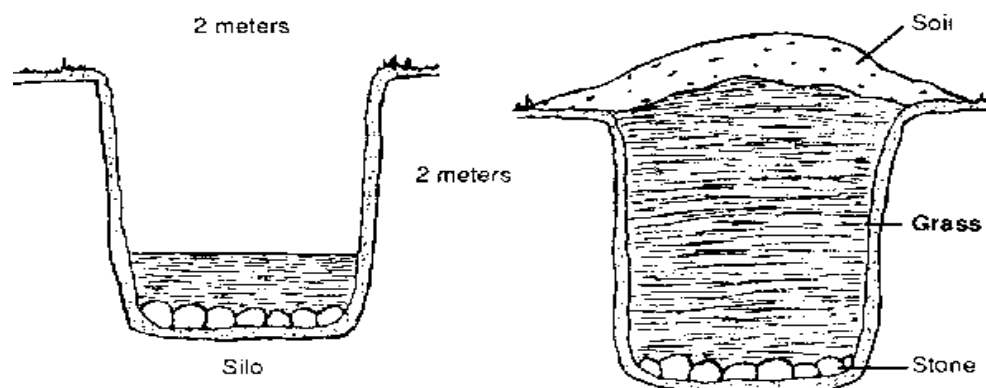

FIGURE 52: SILO

Dig a pit 2 meters deep and 1.5 to 2.0 meters wide. Put a base of large stones in the bottom of the silo. Cut grass and fill the silo with it, stamping down the grass with your feet. The silo must be filled in 1 to 2 days.

When filled cover the top of the silo with a sheet of plastic or stones and a covering of soil in order to keep out water and air. Leave the silage for a few months before using it. The quality of the silage will depend on the plants used. Silage keeps well and animals like it.

FODDER TREES

In some communities' people traditionally cut tree branches to feed their animals. We now know that some trees are better than others for feed. The best trees are leguminous trees (*Leucaena*).

These trees can be grown in rows 4 m apart. Other crops can be grown between the rows of trees (alley farming). The leaves and branches of the trees can be cut through the year and used as animal feed.

Using these trees for feed is beneficial because:

- The leaves of the trees provide good feed for animals all through the year.
- The rotting leaves provide a mineral rich mulch (natural fertilizer) for other crops.

- The trees provide fuel wood, timber and shelter from the wind.
- The trees stop soil erosion and improve the fertility of the soil.

Ask your agriculture officer or veterinarian about using fodder trees.

SUPPLEMENTARY FEEDS

Supplementary feeds are given when the grass is poor and dry or when an animal is pregnant, giving milk or is a working animal.

The best supplementary feed is cake. The cheapest of which is the waste material from the processing of coconuts, groundnuts, cottonseed and palm oil. You can use whatever is available locally.

WATER

Animals need plenty of fresh clean water every day. Always give water before feeding animals and allow them to drink at least three times a day. Ruminants on pastures can be watered every 2 - 3 days. Do not allow animals to stand in the water at the drinking place. This can cause disease to spread. Water needs will vary according to the feed they eat and the weather.

A pinch of salt can be added to the drinking water to provide minerals.

Remember

Take care not to spread disease through feed and water. Keep water and feed troughs clean and do not allow animals to eat old or musty feed.

Change feeds slowly. Take special care when introducing fresh green feed so that bloat is avoided.

New methods of feeding animals have been developed and are used in many countries:

- Feeding urea-treated straw. Straw is a low nutrient feed for ruminants but if it is wetted with urea and covered for a week it becomes more nutritious.
- Molasses-urea-mineral blocks. Blocks made of molasses, mineral salts and urea are a good supplement for ruminants which lick the block and take in the nutrients.

You should talk to the people in your community to discover what they feed their animals. Your local veterinarian or extension worker can advise you on the best types of feed that you can get locally and how they can be used for the livestock in your community. You could encourage your community to make hay or silage for use in the dry season.

34. GRAZING MANAGEMENT

Managing the grazing of pastures by herds and flocks will:

- *Prevent overgrazing of pasture and loss of soil through erosion*
- *Ensure maximum production of animal feed from the land*
- *Help in the control of internal and external parasites*

Learning objectives

After studying this unit you should know:

1. How to manage pastures.
2. What is meant by pasture rotation?
3. The value of managing pastures.

PASTURE MANAGEMENT

Pasture management is the control of pasture grazing by all animals. Pasture should be grazed lightly enough to keep the mature grass growth down but not so much that it is cropped to the ground. If some grasses are not touched by the grazing animals, pull them up before they flower and produce seeds. The livestock should then be moved off the pasture and it is rested to allow the growth of fresh grass. Bushes and trees which goats like to graze will also produce fresh growth.

It may be necessary to move herds some distance to find new grazing. Buffalo and cattle can travel up to 3 km while goats and sheep travel up to 5 km from watering points in search of fresh grazing.

PASTURE ROTATION

Pasture can be fenced or hedged to make protected enclosures. This allows animals to be confined to an area while the neighboring pasture is rested. In this way land, can be grazed for 1 to 2 weeks and then rested for several weeks to allow grass to regrow. This is pasture rotation.

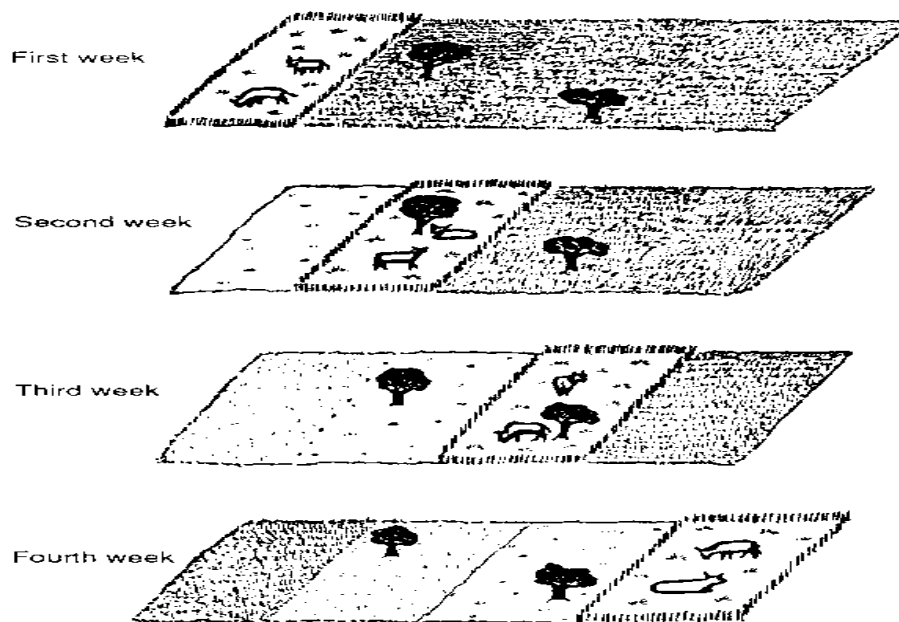

FIGURE 53: PASTURE ROTATION

WHY MANAGE THE GRAZING OF PASTURES?

When the grazing of pastures by livestock is controlled it brings several benefits:

- Herding animals allows them to be watched and any problems such as bloat will be quickly noticed.
- By preventing animals from overgrazing pasture the fertile top soil will be held in place by the plants and their roots. It will not become eroded and the soil is not washed into streams and irrigation channels causing problems for farmers.
- Pasture rotation allows fresh growth of feed plants for the animals. It allows pasture to be left long enough for grasses to produce good roots and seed.
- Fencing areas to keep animals out allows the growing of special feed crops which can later be cut and fed to the animals.
- Pasture rotation helps in the control of both internal and external parasites. Do not always keep young animals on the pasture near the water supplies. It is here that large numbers of parasite eggs build up.

Remember that the grazing ruminant can eat many things as it grazes:

- Wire and nails can pass through the wall of the rumen into the heart and kill. They can also injure the feet.
- Plastic bags can choke an animal and block the stomach.
- Tin cans and glass can cut the mouth, feet and legs.

FODDER VARIETIES AND PRODUCTION:

GREEN FODDER: main source of carbohydrates and crude fiber Varieties include CO3 and CO4, Bermuda (buffalo grass), Cynchrus sps, Napier grass, Congo signal, Fodder sorghum (COFS 27), elephant grass, Sudan grass etc.

LEGUMES: includes Cowpea, horsegram, lucerne, barseem, green gram, black gram, Shanka pushpam (Aparajita – *Clitoria ternatea*), *phillipasara* (*Phaseolus trilobus*), Daincha (*Sesbania bispinosa*)

FODDER TREES:

Subabul, glycericidia, Drum stick, Neem, *Sesbania grandiflora*, *Sesbania sesban*, *Acacia sp*, *Melia dubia*,

STORAGE:

1. Silage:

It is known as pickle of green fodder. It is easily digestible and highly palatable. Best quality silage can be prepared from cereal fodder crops like Maize, Sorghum, Pearl millet, Oats and Barley which are rich in carbohydrates/sugars. Green fodder should be harvested at milking to dough stage of the crop, containing moisture content around 65 to 70 per cent, ideal for silage making. After harvesting, fodder is chaffed to 1 to 2-inch size for filling in silo pit.

Silage storage structure (Silo pit) is to be constructed prior to initiating silage making. Surface silo is an ideal storage structure and to be constructed on raised ground to minimize inflow of water. Size of the silo pit depends on the quantity of fodder to be ensiled. Silo pit with area of one cubic meter (1 metre length x 1 meter width x 1 meter height) is sufficient for ensiling 500 to 600 Kilograms of chaffed fodder. The chaffed fodder is filled in tightly pressed layer of 10 cm each. Pressing of fodder can be done manually in small silo and through tractors on big size silo. After complete filling of silo pit, silage heap should be well sealed at the top with polythene sheet and 5 inches' thick moist soil layer. Later, if some cracks are visible in the covered layer, more soil should be spread to seal it. Use of additives should be

avoided in silage making. However, if fodder is not harvested at proper stage, suitable additives (molasses/common salt/ urea/formic acid) can be used during fodder filling.

After 45 days silage is ready for animal feeding. When green fodder is in deficit, silo pit can be opened from one side to take out the silage as per daily need of animals. It may be covered properly with polythene sheet after taking out of silage daily. Silage is a substitute of green fodder. However, initially for 3 – 4 days, its feeding is limited @ 5 to 10 kg/animal/per day to adjust the animals on silage feeding.



FIGURE 54: CHAFFED FODDER FILLING AND PRESSING IN SILO PIT FULLY SEALED SILO PIT
Silage making is an effective way to conserve green fodder

2. Hay:

Hay is a sun dried green fodder, containing moisture below 15 per cent. It is a good source of digestible dry matter and crude protein for dairy animals during deficit. The best quality hay is prepared from thin stem cultivated fodder crops like Lucerne, Oats and Sweet Sudan Grass during hot and dry summer months from March to May. Some perennial pasture grasses like Guinea grass, Rhodes grass, Anjan/Dhaman grass, Blue panic grass are also suitable for hay making. To get best quality hay, these crops are cut at 50 per cent flowering stage. After cutting, green foliage is evenly spread on dry surface in thin layers of 5 cm thick for sun drying. Every morning after 10 A.M. fodder is inverted manually/mechanically for quick and evenly drying. After 4 to 5 days, when moisture reaches to less than 15 per cent in the forages, hay is collected and bundles are made for storage. While drying, care should be taken that hay retain the leaves and green color, as it is an indicator of good quality hay.

These bundles of hay should be stored in moisture and dust free places like bunkers/godowns to maintain quality for longer period. Hay can be fed @ 5 kg per animal per day with or without chaffing.



FIGURE 55: SUN DRYING OF GREEN FOLIAGE BUNDLES OF HAY

Hay - an alternative to green fodder during deficit period

Enrichment of dry fodder

Straw Treatment Method:

- A. At a time at least 1 ton straw should be treated. We need 40 kg urea and 400 litres of water for the treatment of 1 ton straw.
- B. Dissolve 4 kg urea in 40 litres of water.
- C. Spread 100 kg straw on the floor to form 3-4-inch-thick layer.
- D. Sprinkle 40 litres of prepared urea solution on the straw using gardener's sprinkler. Then press the straw with feet by walking on it.
- E. Spread another 100 kg of dry straw on top of this compressed straw, and prepare another 40 litres of urea solution again by dissolving 4 kg urea in 40 litres of water. Sprinkle the prepared urea solution over the second layer of straw and repeat the compaction by walking on the layer of treated straw. Likewise, repeat the procedure 10 times by spreading 10 layers of straw, sprinkling it with 4 % urea solution and then pressing with feet.
- F. Cover the treated straw heap with a new plastic sheet and spread some quantity of mud at the point where it touches the ground to prevent the formed ammonia gas to escape.
- G. In case plastic sheet is not available, cover the treated heap with dry straw. Then after putting some soil, cover the same with wet clay / or cow dung layer to make it airtight.

Precautions:

Never feed urea or urea solution directly to the animal. Urea as such is fatal to animals.

While treating the straw, keep the urea solution away from the reach of animals. Cemented floor is more appropriate for treatment of straw. If the floor is kaccha, use a plastic sheet on the floor before

spreading the first layer of straw. It is convenient to undertake straw treatment in a closed room or in the corner location. Treated straw should be opened after 21 days in summer and 28 days in winter. Before feeding, the straw should be spread in open air for the ammonia gas to escape. Start with feeding small quantities of treated straw. Slowly the animal gets habituated and starts relishing it.

1. BALANCED RATION:

Balanced ration: It is a ration which supplies all the essential nutrients to the animal in required proportion, form and quantity for 24 hours. Desirable characteristics of good ration.

- A. Ration should be properly balanced with all necessary nutrients.
- B. Ration should include variety of feed stuffs so as to provide better nutrient composition to the body.
- C. Ration should include sufficient green fodders preferably legumes.
- D. Ration should include palatable and digestible feedstuffs so as to ensure optimum feed intake and maximum nutrient availability. as they may reduce the nutrient availability leading to health disorders,
- E. Ration should satisfy the total dry matter requirement of an animal based on weight.
- F. Ration should be fairly bulky as it is required for satisfaction of hunger and expulsion of undigested material due to its laxative action
- G. Ration should be fresh and free from undesirable weeds and dust.
- H. Ration should be properly processed to ensure its desirable intake.
- I. Ration should be economical as feed accounts to about 60 – 70 % cost of animal rearing.

Thumb rule for cattle feeding.

1. The average DM (Dry matter) requirement of desi cow is 2 (dry) to 2.5 (lactating) Kg. / 100 Kg. body weight / day while it is 2.5 (dry) to 3.0 Kg. (lactating) in cross breed cows and buffaloes.
2. The roughage requirement is fulfilled through green and dry fodders, about 2/3 of DM through dry fodder and remaining 1/3 from green fodder
3. The concentrate requirement of animal for maintenance production and pregnancy is as follows:
 - a) Maintenance requirement of desi cow and crossbred cow / buffalo is 1 and 1.5 Kg. respectively.
 - b) Lactating animal should be given 1 Kg. additional concentrate for every 2.5 Kg (Buffalo) to 3 Kg. (Cow) milk produced.
 - c) Pregnant cows, buffaloes should receive 1.5 Kg. per

day extra concentrate allowance during advance pregnancy to meet extra need of nutrients for growth of foetus d) Breeding bulls in service should get 1 Kg. per day extra concentrate. Allowance to maintain good health and sex libido.

4. Mineral mixture and common salt each @ 25-50 gm should be given to fulfill mineral requirement of animal.

MAINTENANCE RATION

It is minimum allowance of ration given to the animal for carrying out its essential body processes at optimum rate without gain or loss in body weight. It is usually given to dry non-producing animals. It roughly satisfies the nutrient requirement for maintenance. Gestation or Pregnancy Ration It is the allowance of ration given to the pregnant animal in addition to maintenance ration during the last quarter of pregnancy. It is given to satisfy nutrient requirement of pregnant animals. It is required for optimum foetal growth. It helps in proper development of udder for future lactation.

PRODUCTION RATION

It is the additional allowance of ration given to the animal over and above the maintenance ration for the purpose of production like milk, meat, wool and work. It is given to meet the nutrient losses through milk. It helps to maintain milk production to optimum level

COMPOUND CATTLE FEED

Compound cattle feed is a mixture of various concentrate feed ingredients in suitable proportion. Commonly used ingredients in compound cattle feed include grains, brans, protein meals/cakes, chunnies, agro-industrial by-products, minerals and vitamins. Compound cattle feed is an economical source of concentrate supplements and it could be in the form of mash, pellets, crumbles, cubes, etc.

Compound cattle feed is palatable and good source of nutrients for growing, adult, dry, milk producing and pregnant animals. Through regular use of compound cattle feed in prescribed quantity along with basal diet, cost of milk production from dairy animals can be optimised and net profitability can be increased. Compound cattle feed needs to be fed as follows:

Particulars	Cows (400 kg body wt.)	Buffaloes (500 kg body wt.)
For maintenance	1.5 - 2.0 kg	2.0 - 2.5 kg
For milk production (per litre)	400 grams	500 grams
For pregnancy	2.0 kg (last two months)	2.0 – 2.5 kg (last two months)

Presently, in India only two types of compound cattle feeds are manufactured for adult animals. Considering the increase in milk yield, regional variation in feed availability, preference of farmers it is required to produce different varieties of compound cattle feed. NDDB also promotes use of different compound feeds such as, calf starter, calf growth meal, feed for high yielding animals, feed for low yielding animals, buffalo feed, feed for dry pregnant animals etc.

NDDB provides cattle feed advisory services to Cattle Feeds Plants (CFPs) under the dairy cooperatives, by providing guidelines on quality of raw materials and finished products. CFPs are also assisted in least cost feed formulation, purchase specifications and test methods of cattle feed raw materials, finished products, including mineral mixture.

CALF NUTRITION

Proper management of young calf is prerequisite to the success of any dairy farm. An optimal level of nutrition in early life favours faster growth and early maturity. Calves should be reared carefully to obtain optimum gain in body weight, so that they attain about 70-75 percent of mature body weight at puberty. Poor feeding of young calves leads to higher age at first calving and overall loss of productivity in the life span.

Important aspects of calf feeding:

1. Colostrum feeding within half an hour of birth
2. Feeding whole milk/ milk replacer to calves
3. Introduction of calf starter/good quality grain from 2nd week onwards
4. Good quality hay should also be given to calves
5. Deworming and vaccination

**Table 7: FEEDING SCHEDULE**

Calf feeding schedule (birth to 26th of week of age)

Period	Colostrum/ Whole Milk (kg/day)	Calf starter (kg/day)	Good quality hay* (kg/day)	Green fodder* (kg/day)
0-2 days	1.5-2.0 (colostrum)	--	--	--
3-4 days	1.5-2.0 (milk)	--	--	--
4-14 days	1.0-1.5 (milk)	0.10	0.10	--
3 rd week	0.5-1.0 (milk)	0.20	0.15	0.75
4 th week	<i>Milk (0.5 kg) or milk replacer (0.25 kg) can be fed, if available with progressive dairy farmers & having good economic conditions</i>	0.25	0.20	1.25
5 th week		0.40	0.30	2.0
6 th week		0.50	0.40	2.5
7 th week		0.60	0.60	3.0
8 th week		0.70	0.80	3.5
9 th week		0.80	0.90	4.0
10 th -11 th wk		1.00	0.90	5.0
12 th week		1.20	1.00	5.0
13 th -16 th wk	1.50	1.20	6.0	
17 th -20 th wk	--	1.75	1.50	7.5
21 st -26 th wk	--	2.00	2.0	8.0

Note: *Requirement of hay and green fodder may vary from breed to breed & body weight of calf. Colostrum feeding is very essential during early life of calf.

BYPASS PROTEIN SUPPLEMENT

Dairy animals have four compartments in its stomach. The first and the foremost is 'rumen' where most of the feed items are degraded. Around 60 to 70 percent of dietary protein meals fed to animals are degraded to ammonia in the rumen. A significant part of this ammonia is excreted through urine in the form of urea. Thus, a large portion of protein from expensive cakes/ meals is wasted. If suitable treatment is given to dietary protein meals, degradation in the rumen can be minimised. This process or treatment to protect dietary protein from degradation in rumen is known as bypass protein technology. These protected meals are digested more efficiently in the small intestine and results in extra protein being available for milk production. This helps the animal to produce more milk and of optimum quality.

NDDB has standardized and commercialized bypass protein technology, using locally available protein meals such as rapeseed meal, sunflower meal, groundnut meal, guar meal and soybean meal. These protein meals are treated suitably to reduce their degradability in the rumen from 60-70 per cent to 25-30 per cent, in a specially designed airtight plant. Treated protein meal can be either fed directly to animals as top feed @ one kg per animal per day or can be incorporated in cattle feed @ 25 per cent and this cattle feed can be fed @ 4-5 kg per animal per day, depending up on the level of milk production. Cost of treatment of protein meals is ₹ 2.5 to 3.0 per kg but considering the resulted increase in milk yield it is always cost effective.

Technical assistance in setting up bypass protein plants is provided to dairy cooperatives and other agencies, for the production of bypass protein supplement/feed.

Animal feed ration:

Maize flour-1/2 kilo; Paddy flour-1/2 kilo; Cotton seeds-1/2 kilo. mix all together and soak them in little water and fed to animal twice a day. It costs Rs.60/animal/day procure maize kernels and paddy and ground them into flour in local flour mill. Paddy is ground into powder without separating rice and bran. Daily about 200 gms of common salt is included in drinking water. The animals are daily taken for grazing in traditional pasture land maintained by them. It is found the quality of milk is superior with good taste and more fat percentage and therefore quantity of ghee is more compared to cross bred animals.

- Pasture rotation increases the fertility of the soil through the animals depositing dung.

Encourage the people in your community to look after the local environment and keep it free from objects that can be a danger to grazing animals and people.

35. COMMON ANIMAL DISEASES AND THEIR PREVENTION AND TREATMENTS

ANTHRAX:

Anthrax, a highly infectious and fatal disease of cattle, is caused by a relatively large spore-forming rectangular shaped bacterium called *Bacillus anthracis*. Anthrax occurs on all the continents, causes acute mortality in ruminants. The bacteria produce extremely potent toxins which are responsible for the ill effects, causing a high mortality rate. The bacteria produce spores on contact with oxygen. Signs of the illness usually appear 3 to 7 days after the spores are swallowed or inhaled. Once signs begin in animals, they usually die within two days. Hoofed animals, such as deer, cattle, goats, and sheep, are the main animals affected by this disease. They usually get the disease by swallowing anthrax spores while grazing on pasture contaminated (made impure) with anthrax spores. Inhaling (breathing in) the spores, which are odorless, colorless, and tasteless, may also cause infection in animals and people. In the case of terrorism, large numbers of anthrax spores may be released into the air.

Causal Organism: It is a bacterial disease caused by *Bacillus anthracis*

Symptoms:

1. Sudden death (often within 2 or 3 hours of being apparently normal) is by far the most common sign;
2. Very occasionally some animals may show trembling, a high temperature
3. Difficulty breathing, collapse and convulsions before death. This usually occurs over a period of 24 hours;
4. After death blood, may not clot, resulting in a small amount of bloody discharge from the nose, mouth and other openings

Treatment and control

1. Due to the acute nature of the disease resulting in sudden death, treatment is usually not possible in animals even though anthrax bacilli are clines. Treatment is of use in cases showing sub-acute form of the disease.
2. In most cases, early treatment can cure anthrax. The cutaneous (skin) form of anthrax can be treated with common antibiotics.
3. Preventive measures:

4. Regular annual vaccination of animals in endemic areas will prevent the disease from occurring.
5. Vaccination may be carried out at least a month prior to expected disease occurrence in endemic areas.
6. Never open a carcass of an animal suspected to have died from Anthrax.
7. Contact a veterinarian immediately if the above symptoms are seen and seek advice on control measures to be adopted.

BLACK QUARTER (BLACK - LEG):

It is an acute infectious and highly fatal, bacterial disease of cattle. Buffaloes, sheep and goats are also affected. Young cattle between 6-24 months of age, in good body condition are mostly affected. It is soil-borne infection which generally occurs during rainy season. In India, the disease is sporadic (1-2 animal) in nature.

Causal Organism: It is a bacterial disease caused by *Clostridium chauvoei*

Symptoms:

1. Fever (106-108°F), Loss of appetite, Depression and dullness
2. Suspended rumination
3. Rapid pulse and heart rates
4. Difficult breathing (dyspnoea)
5. Lameness in affected leg
6. Crepitation swelling over hip, back & shoulder
7. Swelling is hot & painful in early stages whereas cold and painless later.
8. Recumbency (prostration) followed by death within 12-48 hrs.

Treatment:

1. Early treatment can be possible to complete cure of the animal.
2. Consult with veterinarian immediately.

EthnoVet Practice:

The following measure is to be taken up in the month of May / June every year.

Exudates of Thirugukalli (*Euphorbia tirucalli*), Kodikalli (*Sarcostemma brevistigma*), Aththi (*Ficus racemosa*), Banyan tree (*Ficus bengalensis*), Madara (*Calotropis gigantea*) are taken at the rate of 1 to 15 drops each in a stainless-steel vessel and mixed with 50 ml of sesame oil and ragi flour are added and made

into a paste. This paste is applied as dot (coin size) in each animal in the groin region. (The above material may be used for about 50 animals)

FOOT-AND-MOUTH DISEASE:

The foot-and-mouth disease is a highly communicable disease affecting cloven-footed animals. It is characterized by fever, formation of vesicles and blisters in the mouth, udder, teats and on the skin between the toes and above the hoofs. Animals recovered from the disease present a characteristically rough coat and deformation of the hoof. In India, the disease is widespread and assumes a position of importance in livestock industry. The disease spreads by direct contact or indirectly through infected water, manure, hay and pastures. It is also conveyed by cattle attendants. It is known to spread through recovered animals, field rats, porcupines and birds.

Symptoms

- Fever with 104-105 F
- Profuse salivation ropes of stringy saliva hangs from mouth
- Vesicles appear in mouth and in the inter digital space
- Lameness observed
- Cross bred cattle are highly susceptible to it

Treatment

- The external application of antiseptics contributes to the healing of the ulcers and wards off attacks by flies.
- A common and inexpensive dressing for the lesions in the feet is a mixture of coal-tar and copper sulphate in the proportion of 5:1.

Precautions

- Heavy milch animals and exotic breeds of cattle bred for milk should be protected regularly.
- It is advisable to carry out two vaccinations at an interval of six months followed by an annual vaccination programme.
- Isolation and segregation of sick animals. It should be informed immediately to the veterinary doctor
- Disinfection of animal sheds with bleaching powder or phenol
- Attendants and equipment's for sick animals should be ideally separate

- The equipment's should be thoroughly sanitized
- Proper disposal of left over feed by the animal
- Proper disposal of carcasses
- Control of flies

EthnoVet Prevention Practice:

When there is a outbreak in the nearby villages /surroundings take Tulasi (*Ocimum sp*) leaves 100gm, a pinch of common salt and turmeric rhizome 2 pieces and grind them. This has to be squeezed to obtain extract and administered orally. The residues left over can be used for smearing over the mouth region, foot region. This is repeated.

Treatment:

EthnoVet Practices:

1. Banana 5 fruits and sesame oil 100 ml are mixed and fed for a week.
2. Turmeric- 200g (fresh turmeric preferable), Coconut Kernel extract (from 1 coconut), Aloe Vera-200g, jaggary-200g, Salt-100g, Garlic-100g, Cumin-50gm, Fenugreek-50 gm

The above ingredients ground well through grinder /mixi by using sufficient water and collected in a vessel. Then make powder of pepper, cumin, fenugreek and all ingredients are mixed together thoroughly and add sufficient water to make it about 1 liter. Then filter it and administered orally.

Dose:

100 ml at a time for adult animals or 50 ml for young ones or sheep or goats. Before giving the treatment, the animals are to be fed with banana (2number) soaked in sesame oil (50 ml).

3. A special wound healing *thaila* (oil) can be prepared by using following ingredients:

Sesame oil 1 lit, turmeric (freshly harvested preferred or turmeric powder 50gm) 100gm, garlic - 50gm; neem leaves 10 gm, leaves of mehanthi (*Lawsonia inermis*) 10 gm, kuppi (*Acalypha indica*)10 gm. Ground the herbal items and mix with the oil and boil the oil well and filtered. The oil can be stored in a bottle. This *thaila* can be applied over the affected foot region of animals for 3 days continuously or till the point of cure.

Also feed the animal with gruel prepared by boiling with ragi, wheat and bajra flour each 100 gm -200gm with sufficient water in a vessel.

RABIES (MAD DOG DISEASE)

Rabies is a disease of dogs, foxes, wolves, hyaenas and in some places, it is a disease of bats which feed on blood.

The disease is passed to other animals or to people if they are bitten by an animal with rabies. The germs which cause rabies live in the saliva of the sick (rabid) animal.

This is a killer disease but not every dog which bites is infected with rabies.

Learning objectives

After studying this unit you should know:

1. What is rabies.
2. Signs of infection with rabies.
3. What to do with rabid (sick) animals.
4. What to do with animals and people who have been bitten by a rabid animal.

RABIES

This is a disease of the brain which can affect all animals as well as humans. It is caused by germs which are transferred through the bites of rabid (sick) carnivorous animals such as dogs, foxes, wolves, hyaenas and some bloodsucking bats.

When the rabid animal bites another animal or human, the germs which live in its saliva pass into the body through the wound caused by the bite. The germs travel along the nerves to the brain.

The time between the bite and the first appearance of signs that the bitten animal or human has been infected can take from 2 to 10 weeks or more. The time taken depends on the distance of the bite from the brain. If the bite is on the face or head, the bitten animal or human will quickly show signs, but if the bite is on the leg it will take much longer for signs to develop.

GENERAL SIGNS OF RABIES

You should first look for the marks of the bite and discover where and when the animal was bitten. All rabid animals show similar signs in the beginning.

- They change their normal behaviour and behave very strangely.
- They stop eating or drinking.

- There is no change in the body temperature.
- Male animal will try to mate (mount) other animals.

These signs will continue for 3 to 5 days. Then, before it dies, the animal will develop one or the other of two types of the disease:

- The furious (mad) type of the disease makes the animal aggressive and it will bite anything.
- The quiet (dumb) type when the animal is quiet and does not move.

RABIES IN THE DOG

Dogs show either of the two types of rabies.

- A dog with the furious or mad type of the disease will run around and bite anything. The eyes become red and saliva drips from the mouth.
- A dog with the dumb or quiet type of the disease cannot move. It looks as if it has a bone stuck in the mouth and saliva drips from the mouth.
- Rabies in the dog lasts about 10 days before the animal dies. If the animal does not die after this length of time then it may not be suffering from rabies.

RABIES IN SHEEP, GOATS AND CATTLE

Rabies is characterised by the animals becoming restless and excited. They may bite themselves and saliva drips from the mouth. The most important sign in cattle is that the animal bellows (calls) very frequently and with strange sound. The animals will become paralysed and die.

RABIES IN THE HORSE AND CAMEL

The horse will show the furious (mad) type of the disease. It will kick and bite and show signs similar to colic. The animal will die after paralysis of the back legs.

In the camel the signs of rabies are similar to those shown by an animal in the rut.

WHAT TO DO WITH A BITING DOG

Remember that not every dog which bites has rabies.

If the dog belongs to somebody ask the owner about its normal behaviour. If the dog is showing signs of rabies you must inform your veterinary officer immediately. The dog must be shot and if it has bitten anybody, they must be taken to a hospital immediately for vaccination.



FIGURE 56: WHAT TO DO WITH A BITING DOG

CONTROL OF RABIES

Dogs in your community can be vaccinated against rabies. You should ask your veterinary service about vaccination against rabies.

If there is an outbreak of rabies, the livestock in your community can be vaccinated too.

TREATMENT (ETHNOVET PRACTICES) :

Leaves of Chirchra (*Achyranthes aspera*) 100gm and onion 50 gm are ground well and smeared over the bitten place. The extract of these ingredients is administered orally twice in a day.

BLUE TONGUE SYMPTOMS⁵

Bluetongue, a disease which is transmitted by midges, infects domestic and wild ruminants and also camelids, however sheep are particularly badly affected. Cattle, although infected more frequently than sheep, do not always show signs of disease. Virus spreads between animals occurs via the midges of *Culicoides* species.

The likelihood of mechanical transmission between herds and flocks, or indeed within a herd or flock, by unhygienic practices (the use of contaminated surgical equipment or hypodermic needles) may be a possibility.

CLINICAL SIGNS INCLUDE:

Sheep:

- Eye and nasal discharges, Drooling, High body temperature, swelling in mouth, head and neck, Lameness and wasting of muscles in hind legs, Haemorrhages into or under skin, Inflammation of the coronary band, Respiratory problems, Fever, Lethargy.

In cattle

- Nasal discharge, swelling of head and neck, Conjunctivitis, Swelling inside and ulceration of the mouth, Swollen teats, Tiredness, Saliva drooling, Fever.

Note: A blue tongue is rarely a clinical sign of infection

CONTROL:

Inspect stock closely, particularly focusing on the lining of the mouth and nose and the coronary band (where the hoof stops and the skin starts).

If an animal is suspected as having bluetongue, it must be reported as quickly as possible. Telephone your local Animal Health Office immediately.

⁵ <http://www.fwi.co.uk/livestock/blue-tongue-symptoms.htm>

PREVENTIVE MEASURES AND TREATMENT (ETHOVET):

Since the animal is not taking any feed the starvation may lead to death. So the animal has to be administered orally the following food. Banana fruits (one) smeared with Sesame oil (50 ml) for 2 to 3 times. By this animal will recover little. However, this will not control the disease fully. Next the leaf pulp of " Sothukathalai "(*Aloe vera*) has to be administered daily. Administering of *Aloe vera* has to be continued for more days till the animal fully recovers from this disease. By this treatment the infected animal will recover from the disease. The disease will not spread to other animals if all animals are administered with *Aloe vera* as a preventive treatment.

Administering *Aloe vera* also increases the body weight of animals as it is against all intestinal parasite.

SHEEP-POX

Epidemiology

Sheep-pox is a highly contagious disease. It causes a mortality of 20 to 50 per cent in animals below the age of 6 months, and causes damage to the wool and skin in adults. Of the pock diseases, sheep-pox ranks only second to human small-pox in virulence. The disease is transmissible to in contact goats but not to other species of animals. It, however, spreads slowly.

Symptoms

The disease is characterized by high fever, and symptoms of pneumonia and acute enteritis. Skin lesions appear particularly in parts free from wool, notably around the eyes, inner side of the thigh, udder and under surface of the tail. The internal organs such as trachea, lungs, kidneys and intestines are also affected. The disease results in emaciation and, as already mentioned, frequent deaths of affected animals.

⁶Treatment, Prevention and Control:

The diseased animal should be treated with palliatives. In the young ones nursing is more important than medication. The infected litter should be burnt and the bedding changed every day. Affected animals should be kept on soft diet. The ulcers on the skin should be washed with potassium permanganate lotion and dusted with boric acid; strict hygienic measures should be adopted. The method of control by the use of vesicular fluid was in vogue for dealing with sheep-pox. A couple of sheep were first inoculated with the vesicular fluid on the under surface of the tail or the inner side of the ear by scarification. In about 4 to 6 days vesicles appear at the spot, and the fluid collected from these vesicles, mixed with equal parts of glycerol, served as a vaccine. Vaccination was done by scarification inside the ear or under the tail. In about 15 to 20 days, the animals become resistant to the disease.

Preventive Measures and Treatment (EthnoVet):

External application of paste prepared by grinding neem leaves, tulshi leaves each 100 gm and turmeric powder- 50gm sprinkled with sufficient water. Continue for 3 to 5 days. Administer orally the same mixture by diluting with water.

⁶ (Source: Dr.Acharya, Handbook of Animal Husbandry).

BRUCELLOSIS OF SHEEP

Transmission

A large number of organisms are eliminated during abortion. The mode of entry is by ingestion or via conjunctiva. The aborted foetus, vaginal discharge and milk from infected goats contain a large number of organisms.

Symptoms

In infected goats and sheep, a state of abortion may occur followed by a quiescent period during which a few abortions occur. The aborted animals do not breed. After 2 years or more another abortion storm is likely to occur.

Diagnosis, Treatment and Control:

It is not possible to diagnose brucellosis on the basis of symptoms alone. The suspicion is aroused when humans in contact suffer from undulant fever and there is a poor breeding record in the goat herd and evidence of mastitis. The diagnosis can be done by the isolation of organisms and by serological tests.

There is no adequate treatment:

This is based on hygiene, vaccination, testing and disposal. Good management practice is essential. Separate quarters should be provided for kidding. Immunization can be done with attenuated as well as killed vaccines. The test and disposal procedure is highly desirable.

TETANUS

This is an infectious, non-febrile disease of animals and man, and is characterized by spasmodic tetany and hyperaesthesia. This disease is prevalent all over the world.

Transmission

Infection takes place by contamination of wounds. Deep punctured wounds provide favourable conditions for the spores to germinate, multiply and produce toxin which is subsequently absorbed in the animal body. The micro-organism is present in soil and in animal faeces, and is carried into the wound by a penetrating object. The organism is present in the intestine of normal animals, and under some undetermined conditions multiplies rapidly and produces toxin in sufficient quantities to be absorbed and cause the disease.

Symptoms

The incubation period is generally 1-2 weeks but it may be as short as 3 days. Tetanus affects many species of domesticated animals but occurs particularly in horses and lambs; less frequently in adult sheep, goats, cattle, pigs, dog and cats; and rarely in poultry. The initial symptoms are mild stiffness and an unwillingness to move all the animals. More severe symptoms develop after 12-24 hours which are stiffness of limbs, neck, head, tail and twitching of muscles. The spasms develop in response to noise. In terminal stages ears are erect, nostrils dilated, nictitating membrane protruded. Mastication becomes very difficult because mouth cannot be opened, hence the name lockjaw.

Treatment

In cattle changes the recovery with treatment are better than horses or sheep. The treatment is carried out by first injecting antitoxin then treating the wound. Penicillin parenterally is beneficial. Muscular relaxation is achieved by injection of relaxants. The animal should be kept in a dark room and fed with the help of stomach tube.

Control

Proper hygiene and cleanliness at castration and other surgical procedures should be observed. Sheep should be given 2 injections based 3 weeks apart to develop a solid immunity.

LISTERIOSIS

Transmission

The organisms are excreted in the faeces, urine, aborted fetuses, uterine discharge and milk of infected animals. The organisms are sufficiently resistant to remain viable in animal and human faeces, sewage, soil, silage and dust for several weeks and months. The blood sucking arthropods may spread infection since organisms have been isolated from cattle ticks and tabanid flies. Under natural conditions certain predisposing factors are related to clinical infection.

Symptoms

In farm animals the disease occurs towards the end of winter or early spring. The first signs of meningo-encephalitis are stiffness of neck, inco-ordinated movement of limbs and tendency to move in circles or to lean against a fence or wall. There may be paralysis of muscles of jaw and pharynx. Inco-ordination becomes progressively more severe until the animal can no longer stand. The cattle which are not severely affected may survive. Abortions in cattle usually occur after 4-8 months of pregnancy and at a comparatively later stage in sheep. In pigs and horses, clinical signs are not common but may develop as encephalitis and septicaemia. In poultry, the disease usually causes sudden death, occasionally there are signs of torticollis, weakness and inco-ordination of the legs.

Treatment

Tetracyclines are very effective in meningo-encephalities of cattle less so in sheep. The recovery rate depends on the speed with which the treatment is commenced.

Control

When outbreaks occur all affected animals should be slaughtered and buried along with litter and bedding. The vaccines, living or killed, have little effect on the pathogenesis of infection under natural conditions, Tetracycline's are very effective for treatment of listeriosis.

CAMPYLOBACTER ABORTION (VIBRIOSIS):

Transmission

Transmission occurs by coitus. The affected bulls carry the organisms in preputial cavity indefinitely. Mature cows and heifers also carry the infection for long periods. Infected semen from an infected bull is the important means of the disease. The organism survives low temperature used in semen storage.

Symptoms

Infertility may cause become apparent only when the percentage of pregnancies in a dairy herd is low. The infertility rate in heifers is more than in cows. Abortions usually occur between fifth and sixth month of pregnancy. Infected bulls show no symptoms and their semen is normal. Healthy bulls become infected during coitus with diseased cow. Among sheep the disease is characterized by abortion occurring towards the end of gestation. Usually abortion is preceded by vaginal discharge for several days. The aborted foetus is edematous with petechial hemorrhages on serous surfaces and necrotic foci in the liver.

Control

Abortion rate can be reduced by antibiotic therapy, and particularly by using chlortetracycline and concurrently with the development of specific immunity. The use of killed vaccines may reduce the incidence of disease in a herd but does not eradicate the infection. The bulls can be treated by injecting antibiotic cream in the prepuce. There is no direct treatment of females.

7JOHNE`S DISEASE

Johne`s disease is a specific chronic contagious enteritis of cattle, sheep, goat, buffaloes and occasionally of pigs. The disease is characterized by progressive emaciation and in cattle and buffaloes by chronic diarrhea and thickening of the intestine.

Transmission

Under natural conditions the disease spread by ingestion of feed and water contaminated by the faeces of infected animals. The infection occurs mostly in the early month of life. The incubation period extends from 12 months to several years. The animal aged 3 to 6 years mostly suffer from the disease. Affected animals may not show clinical symptoms continue to discharge organisms in faeces. The organisms persist in pastures for about 1 year. The organisms are susceptible to sunlight, drying and high PH of soil; continuous contact of urine with faeces reduces the life of bacteria. In cattle clinical signs appear mainly during 2-6 years of age. The infected animals which are apparently healthy, often show clinical signs after parturition.

Treatment

The organisms is more resistant to chemotherapeutic agents invitro than Mycotuberculosis. Because of this the practical utility of treatment in clinical cases is poor.

Control

The affected animal should be segregated and their faeces Properly disposed off. Alive vaccine has been developed. It reduces the incidence of clinical disease. It consists of a non-pathogenic strain of Jhone`s bacillus with an adjuvant. The calves soon after birth are inoculated with vaccine subcutaneously. The vaccinated animals become reactors of Jhonin. Vaccination is generally done in heavily infected herds.

⁷ Ref: http://agritech.tnau.ac.in/animal_husbandry/animhus_sheep%20disease%20management.html

⁸BOVINE EPHEMERAL FEVER

Bovine ephemeral fever is an insect-transmitted, noncontagious, viral disease of cattle and water buffalo that is seen in Africa, the Middle East, Australia, and Asia. In apparent infections, can develop in Cape buffalo, hartebeest, waterbuck, wildebeest, deer, and possibly goats. Low levels of antibody have been recorded in several other antelope species and giraffe, but the specificity has not been confirmed.

Etiology and Epidemiology

Bovine ephemeral fever virus (BEFV) is classified as a member of the genus *Ephemerovirus* in the family Rhabdoviridae (single-stranded, negative sense RNA)

The prevalence, geographic range, and severity of the disease vary from year to year, and epidemics occur periodically. During epidemics, onset is rapid; many animals are affected within days or 2–3 wk. Bovine ephemeral fever is most prevalent in the wet season in the tropics and in summer to early autumn in the subtropics or temperate regions (when conditions favor multiplication of biting insects); it disappears abruptly in winter. Virus spread appears to be limited by latitude rather than topography or availability of susceptible hosts. Morbidity may be as high as 80%; overall mortality is usually 1%–2%, although it can be higher in lactating cows, bulls in good condition, and fat steers (10%–30%). However, reported overall mortality rates have exceeded 10% in outbreaks in several countries in recent years.

Clinical Findings

Signs, which occur suddenly and vary in severity, can include biphasic to polyphasic fever (40°–42°C [104°–107.6°F]), shivering, inappetence, lacrimation, serous nasal discharge, drooling, increased heart rate, tachypnea or dyspnea, atony of forestomachs, depression, stiffness and lameness, and a sudden decrease in milk yield. Clinical signs are generally milder in water buffalo. Affected cattle may become recumbent and paralyzed for 8 hr to >1 wk. After recovery, milk production often fails to return to normal levels until the next lactation. Abortion, with total loss of the season's lactation, occurs in ~5% of cows pregnant for 8–9 mo. The virus does not appear to cross the placenta or affect the fertility of the cow. Bulls, heavy cattle, and high-lactating dairy cows are the most severely affected, but spontaneous recovery usually occurs within a few days. More insidious losses may result from decreased muscle mass and lowered fertility in bulls.

⁸http://www.merckvetmanual.com/mvm/generalized_conditions/bovine_ephemeral_fever/overview_of_bovine_ephemeral_fever.html

Lesions:

Bovine ephemeral fever is an inflammatory disease. The most common lesions include polyserositis affecting pleural, pericardial, and peritoneal surfaces; serofibrinous polysynovitis, polyarthritis, polytendinitis, and cellulitis; and focal necrosis of skeletal muscles. Generalized edema of lymph nodes and lungs, as well as atelectasis, also may be present.

Diagnosis

Diagnosis is based almost entirely on clinical signs in an epidemic. All clinical cases have a neutrophilia with the presence of many immature forms, although this is not pathognomonic. Serofibrinous inflammation in the tendon sheaths, fascia, and joints, together with pulmonary lesions, may substantiate a presumptive diagnosis.

Laboratory confirmation is by serology, rarely by virus isolation. Whole blood should be collected from sick and apparently healthy cattle in affected herds and must be sufficient to provide two air-dried blood smears, 5 mL of whole blood in anticoagulant (not EDTA), and ~10 mL of serum. A differential WBC count on blood smears can either support or refute a presumptive field diagnosis.

Virus is best isolated by inoculation of mosquito (*Aedes albopictus*) cell cultures with defibrinated blood, followed by transfer to baby hamster kidney (BHK-21 or BHK-BSR) or monkey kidney (Vero) cell cultures after 15 days. Suckling mice may also be used for primary isolation by intracerebral inoculation. Isolated viruses are identified by PCR, neutralization tests using specific BEFV antisera, and ELISA using specific monoclonal antibodies. The neutralization test and the blocking ELISA are recommended for antibody detection and give similar results. A 4-fold rise in antibody titer between paired sera collected 2–3 wk apart confirms infection.

Treatment and Control

Complete rest is the most effective treatment, and recovering animals should not be stressed or worked because relapse is likely. Anti-inflammatory drugs given early and in repeated doses for 2–3 days are effective. Oral dosing should be avoided unless the swallowing reflex is functional. Signs of hypocalcemia are treated as for milk fever. Antibiotic treatment to control secondary infection and rehydration with isotonic fluids may be warranted.

Attenuated virus vaccines appear to be effective but should be used only in endemic areas. Inactivated virus vaccines have not produced longterm protection against experimental challenge with virulent virus and cannot guarantee lasting immunity, but they may boost the immunity produced by live virus vaccine. Although a subunit vaccine that protects against field and laboratory challenge has been described, it is not commercially available. The efficacy of vector control remains uncertain, because the insect vectors have not been fully identified. There is no evidence that people can be infected.

⁹HOG CHOLERA, SWINE FEVER

Classical swine fever is a contagious, often fatal, disease of pigs clinically characterized by high body temperature, lethargy, yellowish diarrhea, vomiting, and a purple skin discoloration of the ears, lower abdomen, and legs. It was first described in the early 19th century in the USA. Later, a condition in Europe termed “swine fever” was recognized to be the same disease. The “high risk period,” ie, the time between introduction of the virus and detection of the outbreak, must be kept as short as possible.

Etiology and Epidemiology

CSF is caused by a small, enveloped RNA virus in the genus *Pestivirus* of the family Flaviviridae.

CSFV is moderately fragile and does not persist in the environment or spread long distances by the airborne route. However, it can survive for prolonged periods in a moist, protein-rich environment such as pork tissues or body fluids, particularly if kept cold or frozen. Virus survival times up to several years have been observed in frozen pork meat. CSFV may also survive months in chilled or cured cuts.

Clinical Findings and Lesions

CSF is characterized by fever, hemorrhages, ataxia, and purple discoloration of the skin; however, the clinical presentation varies, depending on host characteristics and the particular virus strain causing the infection. CSF occurs in several forms, including highly lethal, acute, chronic, or subclinical. Acute forms of CSF, associated with highly virulent CSFV strains, are characterized by an incubation period that is typically 3–7 days, with death occurring within 10 days after infection. Fever > 41°C (105.8°F) is usually seen and persists until terminal stages of the disease when body temperature drops and becomes subnormal. Constipation followed by diarrhea and vomiting is common.

The principal lesion produced by CSFV infection is a generalized vasculitis, clinically manifested as hemorrhages and cyanosis of the skin, notably at the ears, lower abdomen, and extremities. There may also be a generalized erythema of the skin. Vasculitis in the CNS leads to incoordination (ie, staggering gait) or even convulsions. Subacute and chronic forms of the disease are also characterized by high fever, staggering gait, cough, diarrhea, purple discoloration of the skin, and death. In the subacute form, death generally happens within 20–30 days after infection; in the chronic form, death may occur much later. In chronic forms of CSF after an initial acute febrile phase, infected animals may show an apparent recovery but then relapse, with anorexia, depression, fever, and progressive loss of condition (ie, marked weight loss).

⁹http://www.merckvetmanual.com/mvm/generalized_conditions/classical_swine_fever/overview_of_classical_swine_fever.html

Control

CSF is a notifiable disease. Control is usually strictly regulated by local laws that establish strict sanitary measures. No treatment is available. Outbreaks in countries free of CSF are controlled rapidly via culling of infected animals and preemptive slaughter of susceptible animals within determined distances from the focus. Restriction of movement within a well-defined radius from the outbreak is applied to contain spread of the infection. Eventually, emergency vaccination can be authorized to control the further spread of CSFV. Countries will regain their CSF-free status (no antibodies or virus detected) after establishing that CSFV is no longer present in the national pig herd.

RINDERPEST

Rinderpest is the most destructive of the virus diseases of cloven-footed animals, such as cattle, buffaloes, sheep, goats, pigs and wild ruminants. Its control was a major issue till recently all over the world. Organized efforts over half a century have brought about a total eradication of the disease in the Western Hemisphere. The disease still persists in the Asian countries. The virus is found notable in the saliva, discharge from eyes and nostrils, and in the urine and faeces. It is present in the circulating blood during the febrile stage and is later concentrated in different organs, especially in the spleen, lymph nodes and liver. Outside the animal body, the virus is rapidly destroyed by direct sunlight and disinfectants. Cold preserves the virus. The virus is usually spread by contaminated feed and water. Rise in temperature up to 104 – 107 0 F. Lacrimation and redness of eye. Foul odour from mouth. Discrete necrotic foci develop in the buccal mucosa, inside lip, and on the tongue. Bloody mucoid diarrhea is noticed

Preventive Measures:

Treatment:

Symptomatic treatment can be help early cure of the animals.

Consult with veterinary doctor

MASTITIS:

Mastitis, or inflammation of the mammary gland, is the most common and the most expensive disease of dairy cattle throughout most of the world. Although stress and physical injuries may cause inflammation of the gland, infection by invading bacteria or other microorganisms (fungi, yeasts and possibly viruses) is the primary cause of mastitis. Infections begin when microorganisms penetrate the teat canal and multiply in the mammary gland.

Treatment

- Success depends on the nature of the aetiological agent involved, the severity of the disease and the extent of fibrosis.
- Complete recovery with freedom from bacterial infection can be obtained in cases of recent infection and in those where fibrosis has taken place only to a small extent.
- Such drugs as acriflavine, gramicidin and tyrothricin have now ceased to be in use, and have given place to the more effective drugs, such as sulphonamides, penicillin and streptomycin.

FOOTROT

Foot rot is a common cause of lameness in cattle and occurs most frequently when cattle on pasture are forced to walk through mud to obtain water and feed. However, it may occur among cattle in paddocks as well, under apparently excellent conditions. Foot rot is caused when a cut or scratch in the skin allows infection to penetrate between the claws or around the top of the hoof. Individual cases should be kept in a dry place and treated promptly with medication as directed by a veterinarian. If the disease becomes a herd problem a foot bath containing a 5% solution of copper sulphate placed where cattle are forced to walk through it once or twice a day will help to reduce the number of new infections. In addition, drain mud holes and cement areas around the water troughs where cattle are likely to pick up the infection. Keep pens and areas where cattle gather as clean as possible. Proper nutrition regarding protein, minerals and vitamins will maximize hoof health.

TUBERCULOSIS (TB)

Tuberculosis (TB) is a chronic infectious disease of humans, livestock and wildlife. It is an important disease in cattle, buffaloes, pigs and camels. Tuberculosis is present in many countries throughout the world. The germs causing the disease form tubercles or nodules which are found in many organs and especially in the lungs. As the nodules increase in size the organs cannot function and the animal will die. In humans TB usually affects the lungs and causes the patient to cough and spit. In bad cases the patient can spit blood. The disease can kill people.

Learning objectives

After studying this unit you should know:

1. What is tuberculosis.
2. How tuberculosis is spread.
3. Relationship between tuberculosis of humans and animals.
4. Controlling tuberculosis.
5. The tuberculin test.

TUBERCULOSIS

Tuberculosis (TB) is a chronic infectious disease of the respiratory system. The germs which cause the disease form nodules (tubercles) in the organs of the body. It affects the lymph nodes, intestines, udder, skin and especially the lungs.

Human tuberculosis can infect cattle as well as humans. Cattle tuberculosis can infect humans, cattle, buffalo, pigs and camels.

METHODS OF INFECTION

Cattle kept housed are more likely to develop TB than those which live out in the open. The yellowish-white sputum from the lungs which is coughed up by the sick animal contains TB germs. This spreads the infection to other animals.

Milk from infected cows can contain TB germs and spreads the disease to calves and humans.

SIGNS OF THE DISEASE

Tuberculosis of the lungs causes a harsh, dry cough. After a period of time the animal begins to cough up yellowish-white sputum (coughed up mucous).

The milk from infected animals will be normal in color at first. After some time the udder can appear swollen even after milking. The fresh milk will soon look bad with a yellowish liquid forming in it. In bad cases only yellowish liquid will come from the udder.

CONTROL OF TUBERCULOSIS

You will need help from your veterinarian to recognize, to treat and to control tuberculosis.

The tuberculin test is used to check if an animal is infected with TB. The test involves injecting a small amount of solution into the skin of the animals. Only those animals which have TB will show a reaction to the injection. You should ask your veterinarian about the tuberculin test.

It is advisable to boil milk from animals before drinking it. If you slaughter an animal which you suspect may have TB, ask your veterinarian to inspect the meat to see if it is fit to eat. This is because meat from an animal with TB can carry the infection to people who eat it.

Good hygiene, good feeding and good ventilation of any animal houses will prevent the disease from occurring.

¹⁰BOVINE RHINOTRACHEITIS

Infectious Bovine Rhinotracheitis (IBR) is a highly contagious, infectious respiratory disease that is caused by Bovine Herpesvirus-1 (BHV-1). It can affect young and older cattle. In addition to causing respiratory disease, this virus can cause conjunctivitis, abortions, encephalitis, and generalised systemic infections.

IBR is characterized by acute inflammation of the upper respiratory tract.

After the first infection, the virus is never fully removed. It stays behind in nerve cells in the brain as a life-long latent (hidden) infection. However, at times of stress the virus can begin to multiply again and may be re-excreted, generally from the nose and the eyes; an animal which has been infected can never be considered safe.

Purchase of infected animals is the main source of new infections.

Diseases caused by the virus can be serious; therefore, it is a barrier to international trade. Cattle with BoHV-1 antibody cannot be exported to BoHV-1-free countries. Neither can they be accepted into an artificial insemination (AI) centre.

Symptoms

- Fever
- Coughing
- Depression
- Loss of appetite
- Hyperaemia of the mucosae
- Mucosa lesions
- Nasal discharge
- Conjunctivitis
- Drop in milk production
- Infertility
- Abortion

Treatment

There is no direct treatment for viral diseases. Infected animals should be isolated from the rest of the herd and treated with anti-inflammatory drugs and antibiotics for secondary infections if necessary.

¹⁰ <http://www.thecattlesite.com/diseaseinfo/174/infectious-ovine-rhinotracheitis-ibr/>

Carrier cattle should be identified and removed from the herd.

Prevention

Control of the disease is based on the use of vaccines. Since BHV-1 is a ubiquitous, highly contagious virus, vaccination is recommended as soon as passive immunity in calves has disappeared, usually around four to six months of age. Currently available vaccines for IBR include modified-live-virus (MLV) vaccines and inactivated or killed-virus (KV) vaccines.

The timing of vaccination is at least as important as the choice of vaccine. Since maximum protection does not generally occur until approximately three weeks after vaccination, calves should be vaccinated two to three weeks before weaning at which time they start to be at risk of infection.

single vaccination will reduce the severity of disease, but not provide complete protection.

The use of marker vaccines is preferred since the antibody they stimulate can be distinguished from the BoHV-1 antibody that follows a natural infection and so secondary vaccination is required.

Appropriate biosecurity will also reduce risk on farm.

BRUCELLOSIS¹¹

Brucellosis is an infectious disease caused by a type of bacteria called *Brucella*. The bacteria can spread from animals to humans.

There are several different strains of *Brucella* bacteria. Some types are seen in cows. Others occur in dogs, pigs, sheep, goats, and camels.

WHAT CAUSES BRUCELLOSIS?

Brucellosis in humans occurs when a person comes into contact with an animal or animal product infected with the *Brucella* bacteria.

Very rarely, the bacteria may spread from person to person. Breastfeeding moms with brucellosis may pass the bacteria to their baby. *Brucella* may also be spread through sexual contact.

The bacteria can enter your body:

- Through a cut or scratch in the skin
- When you breathe in contaminated air (rare)
- When you eat or drink something contaminated with the bacteria, such as unpasteurized milk or undercooked meat

Four types of *Brucella* bacteria cause the majority of brucellosis infections in humans:

CAN I GET BRUCELLOSIS FROM MY DOG?

Dogs can become infected with *B. canis*. Some pet owners have developed brucellosis this way but the disease is usually mild. There is at least one known case of brucellosis spreading to a human by a dog bite. But spreading brucellosis this way is uncommon. Most dogs infected with *Brucella* do NOT spread the bacteria to their owners.

You are more likely to get brucellosis from an infected dog if you come in contact with blood or other fluids from the animal. Veterinarians have an increased risk of brucellosis.

If you have a weakened immune system due to medications or certain diseases, you should not touch dogs that are infected with *Brucella*.

¹¹ <http://www.webmd.com/a-to-z-guides/brucellosis-symptoms-treatment>

WHAT ARE THE RISK FACTORS FOR BRUCELLOSIS?

In the U.S., brucellosis is more common in men. Men who become sick with the disease most often work or have worked around livestock. Brucellosis is uncommon in children.

You are more likely to get brucellosis if you:

- Eat or drink unpasteurized dairy products from cows, goats, or other animals that are infected with the bacteria
- Eat other unpasteurized cheeses called "village cheeses." These come from high-risk regions, including the Mediterranean
- Travel to areas where *Brucella* is common
- Work in a meat-processing plant or slaughterhouse
- Work on a farm

Brucellosis has also been reported in:

- Hunters in the U.S.
- Veterinarians who have immunized cattle with the *Brucellavaccine*

WHAT ARE THE SYMPTOMS OF BRUCELLOSIS?

General symptoms of brucellosis are often vague and similar to the flu. They may include:

- Fever (the most common symptom, with high "spikes" that usually occur in the afternoon)
- Back pain
- Body-wide aches and pains
- Poor appetite and weight loss
- Headache
- Night sweats Weakness
- Abdominal pain
- Cough

Symptoms usually appear within five to 30 days after you come in contact with the bacteria. How bad your symptoms are depending on what type of *Brucella* is making you sick.

HOW IS BRUCELLOSIS DIAGNOSED?

Your doctor will examine you. You may have:

- A swollen liver
- Swollen lymph nodes
- A swollen spleen

- Unexplained fever
- Joint swelling and pain
- A rash

WHAT ARE THE COMPLICATIONS OF BRUCELLOSIS?

Severe brucellosis may cause:

1. Infection of the central nervous system
2. Endocarditis (infection of the lining of the heart or valves)
3. Liver abscess

Brucellosis can cause long-lasting symptoms that are similar to systemic exertion intolerance disease. SEID is formerly known as chronic fatigue syndrome. The symptoms can lead to disability. They may include:

- Fatigue
- Fevers that come and go
- Joint pain

Brucellosis in a pregnant woman may lead to:

- Miscarriage
- Birth defects in the baby

Death from brucellosis is uncommon. Most brucellosis-related deaths are due to endocarditis.

HOW CAN I PREVENT BRUCELLOSIS?

Brucellosis may be prevented with the following steps:

- Do not drink or eat unpasteurized dairy products.
- Wear rubber gloves if you work in the animal processing industry.

If you have come in contact with an animal infected with *Brucella*, tell your health care provider -- even if you do not have symptoms. You will need to be monitored for at least six months. There is no effective human vaccine to prevent brucellosis.

PIGLET DIARRHEA OR SCOUR

Of all the diseases in the sucking piglet, diarrhea is the most common and probably the most important. In some outbreaks, it is responsible for high morbidity and mortality. The main bacterial causes are *E. coli* and clostridia and the main parasite is coccidia. This section deals principally with *E. coli* diarrhea.

Clinical signs

Scour in the piglet can occur at any age during sucking but there are often two peak periods, before 5 days and between 7 and 14 days.

Acute disease:

The only sign may be a perfectly good pig found dead. Post-mortem examinations show severe acute enteritis, so sudden that there may be no evidence of scour externally. Clinically affected piglets huddle together shivering or lie in a corner. The skin around the rectum and tail will be wet. Look around the pen for evidence of a watery to salad cream consistency scour. In many cases, there is a distinctive smell. As the diarrhea progresses the piglet becomes dehydrated, with sunken eyes and a thick leathery skin. The scour often sticks to the skin of other piglets giving them an orange to white color.

Prior to death piglets may be found on their sides paddling and frothing at the mouth.

Sub-acute disease:

The symptoms are similar but the effects on the piglet are less dramatic, more prolonged and mortality tends to be lower. This type of scour is often seen between 7 to 14 days of age manifest by a watery to thin salad cream consistency diarrhea, often white to yellow in color.

Diagnosis

The overall picture must be considered when making a diagnosis. Sudden outbreaks of scour involving large numbers of litters with acute diarrhea and high mortality suggest TGE, epidemic diarrhea or PRRS. It always helps in differentiating these infections to know whether the herd had previously been exposed to any of these diseases or not. If exposure is for the first time the outbreak is likely to be explosive.

Rotavirus diarrhea appears in waves in individual litters or groups of litters and normally in the second half of lactation. Coccidiosis has an incubation period of 6 days and is usually involved in diarrhea complexes from 7 to 14 days of age. At less than 5 days of age the most common cause is *E. coli* with acute diarrhea particularly in gilts' litters because they pass on poorer levels of immunity. Clostridial infections also occur at this age.

Diagnosis is based on the clinical examinations, the response to treatment (viral diseases do not respond to treatment) and laboratory examination of the scour. Submit a rectal swab or a live pig to the laboratory for cultural examinations and antibiotic sensitivity tests.

Treatment

- Some antibiotics available are shown in Fig.8-30. Most of these are active against *E. coli* and clostridia but not the virus infections.
- In severe outbreaks of *E. coli* disease the sows feed can be top dressed with the appropriate antibiotic daily, from entry into the farrowing house and for up to 14 days post-farrowing. This can be effective in reducing bacterial output in the sows faeces.
- Observe litters for the presence of diarrhea both night and morning.
- Study the history of the disease on your farm. Is it sporadic, in one piglet in a litter, or total litters?
- In the light of the history either treat the individual pig or on the first signs of disease treat the whole litter.
- If a litter is badly scoured dose night and morning for a minimum of two days.
- Assess the response to treatment. If there is no change within 12 hours, then change to another medicine as advised by your veterinarian.
- Always treat piglets less than 7 days of age by mouth.
- For older pigs where the disease is less acute injections are equally effective and easier to administer.
- Provide electrolytes in drinkers. These prevent dehydration and maintain body electrolyte balances.
- Cover the pen, the creep area and where the pigs defecate with straw, shredded paper, shavings or sawdust.
- Provide an additional lamp to provide an extra source of heat.
- Use binding agents such as chalk, kaolin or activated attapulgit to absorb toxins from the gut.

Management control and prevention

- Adopt procedures to prevent the spread of the scour.
 - Disinfect boots between pens. - Use a disposable plastic apron when dosing piglets to prevent heavy contamination of clothing. - Wash hands after handling a scoured litter. - Disinfect brushes and shovels between pen.
- Ensure that farrowing houses are only used on an all-in all-out basis with a pressure wash and disinfection between each batch.

- Farrowing pens must be dry before the house is repopulated. Remember that moisture, warmth, waste food and faeces are ideal for bacterial multiplication.
- Pen floors should be well maintained. Poor pen hygiene associated with bad drainage predisposes to scour.
- Look carefully at the part of the pen floor where there are piglet faeces. Is this poorly drained? Do large wet patches develop? If so cover them with extra bedding daily and remove. This is a most important aspect of control.
- Check nipple drinkers and feeding troughs for leakages.
- Ensure that faeces are removed daily from behind the sow from the day she enters the farrowing crates until at least 7 days post-farrowing if the floors are slatted. Also remove faeces daily throughout lactation if they are solid concrete.
- Maintain creep environments that are always warm and comfortable. Fluctuating temperatures are a major trigger factor to scour particularly from 7 to 14 days of age.
- Do not penny-pinch on your heating costs. Many cases of scour are precipitated by attempts to save on costs of energy.
- Check for high air flow and draughts. They predispose to scour.
- Consider vaccinating against *E. coli* (make sure first that this is the cause of the problem however). *E. coli* vaccines only protect the piglet for the first 5 to 7 days of age.
- Assess the environment of all the farrowing house. Poor environments allow heavy bacterial multiplication and a much higher bacterial challenge is likely to break down the colostral immunity.
- Check the sow's health. Animals affected with enteric or respiratory disease, lameness or mastitis predispose the litter to scour.
- Avoid the use of milk replacers where possible. Their routine use, particularly if they are allowed to get stale or contaminated, may increase the incidence.
- Where farrowing house floors are very poor, pitted and difficult to clean, brush them over with lime wash containing a phenolic disinfectant.
- Scour is more common in large litters. Split suckling should be adopted.

Colostrum management

- It is vital that the piglet receives the maximum amount of colostrum within the first 12 hours of birth. High levels of antibody are only absorbed during this period. Factors such as poor teat access, poor crate design, and particularly the development of agalactia in the sow, associated with udder oedema, reduce intake.

- In an outbreak of scour it is important to establish if udder oedema is present. It is more common in gilts and second parity than in older sows. If *E. coli* diarrhea is a problem in younger aged females this suggests that immunity levels are low and vaccination should be considered. Inject the sow twice 2 to 4 weeks apart the second injection at least two weeks before farrowing, but these times are variable depending upon the vaccine used. With good management, it should not be necessary to vaccinate the sows, only the gilts.

Eradication

- It is not possible to eliminate organisms such as rotavirus *E. coli* and coccidiosis from the herd and most if not all pigs will be infected with them. Herds can be maintained free of TGE, PED and PRRS. All herds carry clostridia but other factors are required to cause disease.

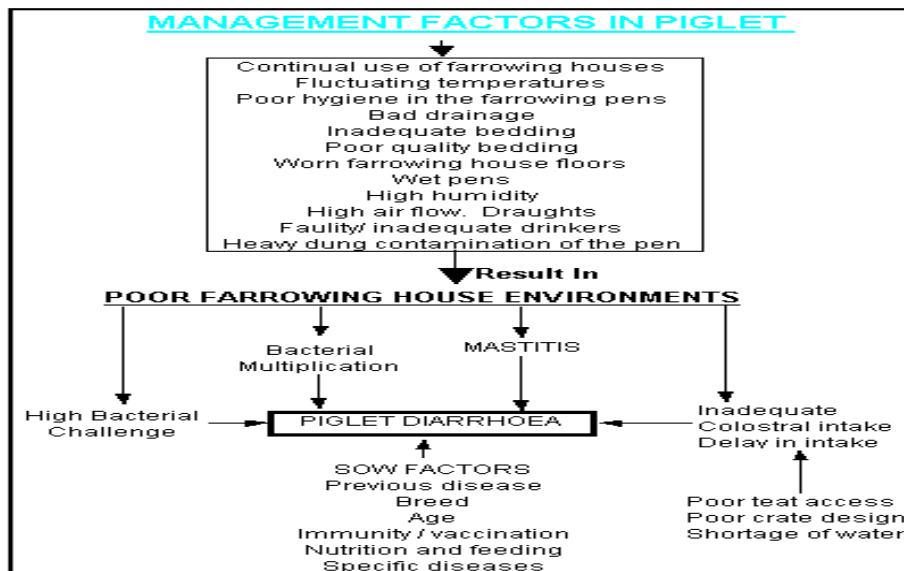

FIGURE 57: MANAGEMENT FACTORS IN PIGLETS

PPR (GOAT PLAGUE)¹²

PPR (*peste des petits ruminants*) is a most important viral disease of goat capable of heavy mortality and commonly called as goat plague. The other synonyms of the disease are psuedorinderpest of small ruminants, pest of small ruminants, Kata, stomatitis-pneumoenteritis syndrome, contagious pustular stomatitis, pneumo-enteritis complex based on resemblance to rinderpest of cattle, species affected, location and symptoms

Etiology

The causative virus was first thought to be an aberrant strain of rinderpest virus that had lost its ability to infect cattle. Later molecular studies showed that it was distinct from, but closely related to, rinderpest virus

Susceptible species and transmission:

Principally PPR is a disease of goats and sheep. Comparatively disease is more severe in goats than sheep. Kids >4 months and < 1 year of age are also most susceptible. In endemic areas, most of the sick and dying animals are >4months and up to 18 to 24 months of age.



FIGURE 58: SUSCEPTIBLE SPECIES AND TRANSMISSION

¹² <http://www.vethelplineindia.co.in/ppr-control-in-goat-a-guide-for-animal-health-service-providers/>

Pathogenesis and Clinical signs:

Pathogenesis of PPR virus is similar to that of rinderpest in cattle. Virus penetrates the retropharyngeal mucosa, sets up a viremia and specifically damages the alimentary, lymphoid and respiratory system. Death may occur from severe diarrhea, sometimes hasten by concurrent diseases. Lymphoid necrosis is not so marked as in rinderpest and immunosuppression. This characteristic often makes affected goat succumb to diseases like contagious ecthyma or blue tongue post infection with PPR virus. Reproductive problems associated during the outbreak and post outbreak of PPR has been reported by researchers. PPR causes abortion in pregnant does and there is vulvo-vaginitis in female goats affected with PPR.

The clinical sign of PPR in goats is often fulminating and fatal although apparent infection occurs in endemic areas. Incubation period may range from 2-6 days in field conditions. In acute form, there is sudden onset of fever with rectal temperature of at least 40°- 41°C. The affected goats show dullness, sneezing, serous discharge from the eyes and nostrils. During this stage farmers often think that the animal has developed cold exposure and may attempt to provide protection for cold. In the process goats, may be congregated and accentuate the process of transmission. After 2-3 days, discrete lesions develop in the mouth and extend over the entire oral mucosa, forming diphtheric plaques.

During this stage profound halitosis (foul smell) is easily appreciable and the animal is unable to eat due to sore mouth and swollen lips. Latter ocular discharge becomes mucopurulent and the exudate dries up, matting the eyelids and partially occluding the nostrils. Diarrhea develops 3-4 days after the fever and is profuse and faeces may be mucoid or bloody depending upon the damage. Dyspnea and coughing occur later due to secondary pneumonia. Death occurs within one week of the onset of the illness.

Treatment and Control:

No specific treatment is recommended for PPR being viral disease. However, mortality rates can be reduced by the use of drugs that control the bacterial and parasitic complications. Specifically, Oxytetracycline and Chlortetracycline are recommended to prevent secondary pulmonary infections. Lesions around the eyes, nostrils and mouth should be cleaned twice daily with sterile cotton swab. Our experience indicates that fluid therapy and anti-microbial such as Enrofloxacin or Ceftiofur on recommended doses along with mouth wash with 5% boro-glycerine can be of benefit in reducing the mortality during outbreak of PPR in goats. Health workers should inspect first the unaffected goats followed by treatment of affected goats. Immediate isolation of affected goats from clinically healthy goats is most importance measure in controlling the spread of infection. Nutritious soft, moist, palatable diet should be given to the affected goats. Provide parenteral energy infusion in anorectic goats along with appetizers.

Immediately measures should be taken for notification of disease to nearest government veterinary hospital. Carcasses of affected goats should be burned or buried. Proper disposal of contact fomites, decontamination is must. Vaccination is the most effective way to control PPR.

Rinderpest tissue culture vaccine was initially used to protect small ruminants and at present is obsolete. Now homologous PPR vaccine is being used. The vaccine can protect small ruminants against PPR for at least for 3 years. Dose of PPR vaccine available in market is 1 ml and can be given sub cutaneous route at the age of 4 months. Males and goats kept for more than 3 years may be revaccinated after 3 years. It is important to note that farmers should be asked to avoid providing any stress such as transportation, inclement weather, etc. to the goat for a period of at least 3 weeks' post-vaccination.

Conclusion

Goat farming has immense potential to expand. The limitation arising out of animal health problems in goat rearing can be managed by bringing awareness among goat farmers and entrepreneurs regarding major disease/conditions of economic importance such as PPR. Control measures are available and effective; however, implementation on the part of the individual farmers and government needs to have a greener shade.

BOVINE BABESIOSIS (TICK FEVER)¹³

CAUSE

Bovine Babesiosis (BB) is a tick-borne disease of cattle.

The principal strains are *babesia bovis* and *babesia bigemina*, with Rhipicephalus ticks being the major vector. *Babesia divergens* is also found, with the major vector being Ixodes ricinus.

BB is found in areas where its arthropod vector is distributed, especially tropical and subtropical climates. *Babesia bovis* and *B. bigemina* are more widely distributed and of major importance in Africa, Asia, Australia, and Central and South America. *Babesia divergens* is economically important in some parts of Europe and possibly northern Africa.

Transmission of *B. bovis* takes place when engorging adult female ticks pick up the infection. They pass it on to their progeny via their eggs. Larvae (or seed ticks) then pass it on in turn when feeding on another animal. *B. bigemina* is also passed from one generation of ticks to the next. Engorging adult ticks pick up the infection and nymphal and adult stages (not larval stages) of the next generation pass it on to other cattle.

Morbidity and mortality vary greatly and are influenced by prevailing treatments employed in an area, previous exposure to a species/strain of parasite, and vaccination status. In endemic areas, cattle become infected at a young age and develop a long-term immunity. However, outbreaks can occur in these endemic areas if exposure to ticks by young animals is interrupted or immuno-naïve cattle are introduced. The introduction of *Babesia* infected ticks into previously tick-free areas may also lead to outbreaks of disease.

Symptoms:

B. bovis

Conditions are often more severe than other strains.

- High fever
- Parasitaemia (percentage of infected erythrocytes) - maximum parasitaemia is often less than one per cent.
- Neurologic signs such as incoordination, teeth grinding and mania. Some cattle may be found on the ground with the involuntary movements of the legs. When the nervous symptoms of cerebral babesiosis develop, the outcome is almost always fatal.

¹³ <http://www.thecattlesite.com/diseaseinfo/196/bovine-babesiosis-redwater-tick-fever/>

- Dark colored urine
- Anorexia
- *B. bigemina*
- Fever
- Anorexia
- Animals likely to separate from herd, be weak, depressed and reluctant to move
- Haemoglobinuria and anaemia Dark colored urine
- Central nervous system (CNS) signs are uncommon
- Lesions
- In *b. bigemina* parasitaemia often exceeds 10 per cent and may be as high as 30 per cent.

Clinical symptoms for *Babesia divergens* are similar to *B. bigemina* infections.

The survivors may be weak and in reduced condition, although they usually recover fully. Subacute infections, with less apparent clinical signs, are also seen.

Treatment

Mild cases may recover without treatment.

Sick animals can be treated with an antiparasitic drug. Treatment is most likely to be successful if the disease is diagnosed early; it may fail if the animal has been weakened by anemia.

Imidocarb has been reported to protect animals from disease but immunity can develop. There are also concerns with regard to residues in milk and meat.

In some cases blood transfusions and other supportive therapy should be considered.

Prevention

Effective control of tick fevers has been achieved by a combination of measures directed at both the disease and the tick vector. Tick control by acaricide dipping is widely used in endemic areas.

Dipping may be done as frequently as every 4-6 weeks in heavily infested areas. The occurrence of resistance of ticks, chemical residues in cattle and environmental concerns over the continued use of insecticides has led to use of integrated strategies for tick control.

Babesiosis vaccines are readily available and are highly effective. Anti-tick vaccines are also available in some countries and can be used as part of an integrated program for the control of ticks.

Babesiosis can be eradicated by eliminating the host tick(s). In the US, this was accomplished by treating all cattle every two to three weeks with acaricides. In countries where eradication is not feasible, tick control can reduce the incidence of disease.

Treatment for control of tick (EthnoVet):

Mix common salt and few camphor in castor oil or neem oil and apply over the affected area. Whole plant extract of *ghaner* (*Lantana camara*) should be diluted with the urine of cattle and apply externally. Boil 250 gm of tobacco in 2 litres of water and add 5 litres of water and sprayed over the body of 10-20 animals.

THEILERIOSIS

Theilerias are a group of tickborne diseases caused by *Theileria* spp. Both *Theileria* and *Babesia* are members of the suborder Piroplasmorina. Although *Babesia* are primarily parasites of RBCs, *Theileria* use, successively, WBCs and RBCs for completion of their life cycle in mammalian hosts. The infective sporozoite stage of the parasite is transmitted in the saliva of infected ticks as they feed. Sporozoites invade leukocytes and, within a few days, develop to schizonts. In the most pathogenic species of *Theileria* (eg, *T parva* and *T annulata*), parasite multiplication occurs predominantly within the host WBCs, whereas less pathogenic species multiply mainly in RBCs. Development of the schizont stage of pathogenic *Theileria* causes the host WBC to divide; at each cell division, the parasite also divides. Mortality in such stock is relatively low, but introduced cattle are particularly vulnerable. Unlike in babesiosis, in theileriasis there is no evidence of increased resistance in calves <6 mo old.

EAST COAST FEVER

East Coast fever, an acute disease of cattle, is usually characterized by high fever, swelling of the lymph nodes, dyspnea, and high mortality. Caused by *Theileria parva*, and transmitted by the tick vector *Rhipicephalus appendiculatus*, it is a serious problem in east and southern Africa.

Etiology and Transmission

The African buffalo (*Syncerus caffer*) is an important wildlife reservoir of *T parva*, but infection is asymptomatic in buffalo. *T parva* transmitted by ticks from either cattle or buffalo cause severe disease in cattle, but buffalo-derived parasites differentiate poorly to merozoites in cattle and generally are not transmitted by ticks. Hence, buffalo *T parva* are maintained as a separate population. Buffalo *T parva* were previously considered a separate subspecies (*T parva lawrencei*), but DNA typing indicate that the cattle and buffalo parasites are a single species. *T parva* is usually highly pathogenic, causing high levels of mortality, although some less pathogenic isolates have been identified.

Pathogenesis, Clinical Findings, and Diagnosis

T parva sporozoites are injected into cattle by infected vector ticks. An occult phase of 5–10 days follows before infected lymphocytes can be detected in Giemsa-stained smears of cells aspirated from the local draining lymph node. Subsequently, the number of parasitized cells increases rapidly throughout the lymphoid system, and from about day 14 onward, cells undergoing merogony are observed. This is associated with widespread lymphocytolysis, marked lymphoid depletion, and leukopenia. Piroplasms in RBCs infected by the resultant merozoites assume various forms, but typically they are small and rod-shaped or oval.

Clinical signs vary according to the level of challenge, and they range from inapparent or mild to severe and fatal. Typically, fever occurs 7–10 days after parasites are introduced by feeding ticks, continues throughout the course of infection, and may be $>106^{\circ}\text{F}$ (41°C). Lymph node swelling becomes pronounced and generalized. Lymphoblasts in Giemsa-stained smears of needle aspirates from lymph nodes contain multinuclear schizonts. Anorexia develops, and the animal rapidly loses condition; lacrimation and nasal discharge may occur. Terminally, dyspnea is common. Just before death, a sharp decrease in body temperature is usual, and pulmonary exudate pours from the nostrils. Death usually occurs 18–24 days after infection. The most striking postmortem lesions are lymph node enlargement and massive pulmonary edema and hyperemia. Hemorrhages are common on the serosal and mucosal surfaces of many organs,

sometimes together with obvious areas of necrosis in the lymph nodes and thymus. Anemia is not a major diagnostic sign (as it is in babesiosis) because there is minimal division of the parasites in RBCs, and thus no massive destruction of them.

Animals that recover are immune to subsequent challenge with the same strains but may be susceptible to some heterologous strains. Most recovered or immunized animals remain carriers of the infection.

Treatment and Control

Treatment with parvaquone and its derivative buparvaquone is highly effective when administered in the early stages of clinical disease but is less effective in the advanced stages, in which there is extensive destruction of lymphoid and hematopoietic tissues. Immunization of cattle against *T parva* using an infection-and-treatment procedure is practical and continues to gain acceptance in some regions. The components for this procedure are a cryopreserved sporozoite stablate of the appropriate strain(s) of *Theileria* derived from infected ticks and a single dose of long-acting oxytetracycline given simultaneously; although oxytetracycline has little therapeutic effect when administered after development of disease, it inhibits development of the parasite when given at the outset of infection. Cattle should be immunized 3–4 wk before being allowed on infected pasture. Parasitized bovine cells containing the schizont stage of *T parva* and *T annulata* can be cultivated in vitro as continuously growing cell lines. In the case of *T annulata*, cattle can be infected with a few thousand cultured cells. Attenuated strains produced by serial passage of such cultures form the basis of live vaccines used in several countries, including Israel, Iran, India, and the former USSR.

Incidence of East Coast fever can be reduced by rigid tick control, but this is not feasible in many areas because of cost and the high frequency of acaricidal treatment required.

TROPICAL THEILERIOSIS¹⁴

Theileria annulata, the causal agent of tropical theileriosis, is widely distributed in north Africa, the Mediterranean coastal area, the Middle East, India, the former USSR, and Asia. It is transmitted by several species of ticks of the genus *Hyalomma*. *T annulata* can cause mortality of up to 90%, but strains vary in their pathogenicity. The kinetics of infection and the main clinical findings are similar to those produced by *T parva*, but unlike in East Coast fever, anemia is often a feature of the disease. Characteristic signs include fever and swollen superficial lymph nodes. If the disease progresses, cattle rapidly lose condition. The schizonts and piroplasms are morphologically similar to those of *T parva*. Animals that recover from infection are immune to subsequent challenge. Treatment and control are as described for East Coast fever

OTHER THEILERIASES OF CATTLE

The *Theileria orientalis* group, consisting of the closely related parasites *T orientalis*, *T buffeli*, and *T sergenti*, has a worldwide distribution. These parasites are transmitted by ticks of the genus *Haemaphysalis*. The piroplasms are larger than those of *T parva* and *T annulata*, and they multiply principally by intraerythrocytic division. Mortality, particularly in indigenous cattle, is rare, but infection can sometimes result in progressive chronic anemia. *T mutans* and *T velifera* are found in Africa, where they are transmitted by ticks of the genus *Amblyomma*. Multiplication occurs mainly by intraerythrocytic division. The piroplasms are morphologically indistinguishable from those of *T orientalis* and *T taurotragi* (an African parasite of eland and cattle), but the parasites can be differentiated by serologic tests such as indirect fluorescent antibody and by DNA typing. Some strains of *T mutans* are pathogenic as well. In addition, concurrent infection may add to the pathogenicity of *T parva*.

OVINE AND CAPRINE THEILERIASES

Theileria lestoquardi (formerly *T hirci*) causes a disease in sheep and goats similar to that produced in cattle by *T annulata*, with which it is closely related. *T lestoquardi* is transmitted by ticks of the genus *Hyalomma*. The limited available epidemiologic data indicate that *T lestoquardi* has a more restricted geographic distribution than that of *T annulata*, being particularly prevalent in the Middle East and northeast Africa. Mortality can approach 100%. Schizonts can readily be demonstrated in Giemsa-stained smears of needle biopsies from swollen superficial lymph nodes.

¹⁴ http://www.merckvetmanual.com/mvm/circulatory_system/blood_parasites/theilerias.html

Recently, two species of *Theileria*, *T lewenshuni* and *T uilenbergi*, have been identified as the causal agents of a severe disease in sheep in China. These species are morphologically indistinguishable and cause similar disease but can be distinguished by DNA typing methods. They are transmitted by ticks of the genus *Haemaphysalis*. Schizonts are detected in a range of tissues, but later and in smaller numbers than in other pathogenic *Theileria* spp. Piroplasms are consistently detected in RBCs. Morbidity and mortality rates of up to 65% (*T lewenshuni*) and 75% (*T uilenbergi*) have been seen in susceptible animals introduced into endemic areas. Affected animals show sustained fever and anemia.

Treatment for control of tick (EthnoVet):

Mix common salt and few camphor in castor oil or neem oil and apply over the affected area. Whole plant extract of *ghaner* (*Lantana camara*) should be diluted with the urine of cattle and apply externally. Boil 250 gm of tobacco in 2 litres of water and add 5 litres of water and sprayed over the body of 10-20 animals.

RINGWORM:

This is the most common infectious skin disease affecting beef cattle. It is caused by a fungus, and is transmissible to man. Typically, the disease appears as crusty grey patches usually in the region of the head and neck and particularly around the eyes.

As a first step in controlling the disease, it is recommended that, whenever possible, affected animals should be segregated and their pens or stalls cleaned and disinfected. Clean cattle which have been in contact with the disease should be watched closely for the appearance of lesions and treated promptly. Proper nutrition, particularly high levels of Vitamin A, copper and zinc while not a cure, will help to raise the resistance of the animal and in so doing offer some measure of control. Contact your vet and or feed store for products to treat this disease. Using a wormer like Ivomec will kill lice and help prevent cattle from scratching causing skin damage and a place for the fungus to enter.

MILK FEVER¹⁵

- Milk fever, also known as parturient hypocalcaemia and parturient paresis, is a disease which has assumed considerable importance with the development of heavy milking cows.
- Decrease in the levels of ionized calcium in tissue fluids is basically the cause of the disease.
- In all adult cows, there is a fall in serum-calcium level with the onset of lactation at calving.
- The disease usually occurs in 5 to 10-year-old cows, and is chiefly caused by a sudden decrease in blood-calcium level, generally within 48 hours after calving.

Symptoms

- In classical cases, hypocalcaemia is the cause of clinical symptoms. Hypophosphataemia and variations in the concentration of serum-magnesium may play some subsidiary role.
- The clinical symptoms develop usually in one to three days after calving. They are characterized by loss of appetite, constipation and restlessness, but there is no rise in temperature.

¹⁵ <http://www.krishisewa.com/articles/livestock/118-cattles-disease.html>

CALF SCOUR

HOW TO DIAGNOSE AND TREAT SCOURS IN CALVES

Calves may develop scours due to bacterial or virus infections. Scours is known as "calf scours" or neonatal calf diarrhea. The primary causes of scours include: Rota virus, Corona virus, *Cryptosporidium parvum*, *Salmonella*, and *Escherichia coli*.

Step1

Determine if treatment is required. Calves that are moving around in the pasture, with their tails up, probably do not need treatment. Check to see if the diarrhea is yellow or white. If this is the case, treatment is probably not needed.

Step2

Determine if the calf is looking listless. Calves that are lethargic or not participating much in the playful activities with other calves are a red flag to pay attention to. Calves that are also losing condition are also cause for alarm.

Step3

Check to see if the calf is dehydrated. You can check for dehydration by pulling on the calf's neck skin. If the skin "tents" this is a sign of dehydration.

Step4

Determine the calf's body temperature. A normal body temperature ranges from 100.5 °F (38.1 °C) to 102.5 °F (39.2 °C). Anything outside of this range is a sign for treatment.

Step5

Separate the sick calf or calves from the healthy herd. You'll want to do this to avoid spreading the disease further.

Step6

Administer fluids using your veterinarian-approved electrolyte solution. You may need to inject the fluids via IV or orally. Follow the package directions when mixing up the solution.

- Feeding the calf water will not work because it will simply pass through his system and not be completely absorbed.

Step7

Follow up with antibiotics, if approved by your vet.

Step8

Follow appropriate nursing care protocol using your vet's guidelines. This may include providing shelter, feed and a warm place to sleep.

A drawback from providing shelter is maintaining infectious control. You will have to work extra to get rid of soiled bedding and disinfect everything that a calf will touch, from the floor to the fence panels and even the feed bucket.

EnthnoVet practice:

Ingredients needed: Vasambu (*Acorus calamus*) leaves 2 numbers, Dried ginger (*Zingiber officinale*) 50 gm, Guava (*Psidium guajava*) tender leaves 200 gm.

The above materials are ground and made into a bolus and administered orally one or two times.

36. COMMUNITY QUESTION & ANSWER¹⁶

1. What is the best injectable medicine for calf scours?

Answer: There is no injectable medicine available. Scour boluses are available, but generally they're for young calves with bacterial infection of the gut. You may also need to use electrolytes and make sure bedding is cleaned out regularly. Scours is just a symptom of a bunch of different possible diseases or conditions, from feeding too much milk to a gut bacterial infection caused by E. coli, Campylobacteria, Salmonella, etc., or some other illness. Please talk with your vet about treating scours in your calves.

2. I have a calf I'm bottle feeding (50-60 pounds), and it has the scours. What can I do?

Answer: Please contact your veterinarian to see what's going on. Scours is merely a symptom of something else, whether it's too much milk, some gut bacteria causing problems, or another issue that needs to be addressed. You can also start giving the calf electrolytes to make sure it has enough fluids in its system. Don't feed milk at the same time as you're giving them electrolytes.

3. Should I move heifers to a clean pasture, even though cold will be a factor?

Answer: Not a great idea if you don't have a portable shed and bedding to go with it. Clean the barn or stall out and keep replacing old straw with the new so they stay warm. Cold calves won't be healthy calves if they don't have shelter and bedding to lay in. A south-facing shed is perfect for them to stay warm, if you don't have a barn or stable, out in a field or pasture.

4. Can I give a calf too many electrolytes? What if I am wrong about scours -- will they get diarrhea?

Answer: Electrolytes are just vitamins and minerals mixed in water, so too much by accident won't hurt, but don't continuously overdo it because it may cause problems. Scours is diarrhea in calves, and you can't go wrong when you see a calf have runny poop rather than the normal miniature cow-pat that they should have. If you're saying you gave the wrong calf electrolytes, no it won't hurt him, just make sure a) you have the right calf to treat, and b) you follow directions on the package.

¹⁶ <http://www.wikihow.com/Diagnose-and-Treat-Scours-in-Calves>

HEMORRHAGIC SEPTICAEMIA

Synonyms: Pasturellosis, shipping fever, ghatsurp

It is an actual infectious disease of cattle, buffalo, sheep and goat. It distances transportation. In India, the disease is enzootic in nature. Etiology environmental conditions, malnutrition and long distance transportation. In India, the disease is enzootic in nature.

Etiology: It is caused by *Pasteurella multocida*

Transmission:

1. Ingestion of contaminated feed and water and
2. Inhalation.

Symptoms:

1. High fever (106 - 107°F)
2. Loss of appetite
3. Suspended rumination
4. Dullness and depression
5. Rapid pulse & heart rate
6. Profuse salivation and laceration.
7. Profuse nasal discharge
8. Difficult/snoring respiration
9. Swelling of throat region (submandibular oedema)
10. Death within 10-72 hours.

Diagnosis:

1. History of season, climate & stress factor.
2. Symptoms -high fever, swelling of throat region.
3. Postmortem findings - hemorrhages throughout body & submandibular edema.
4. Examination of blood smears and smears from oedematous fluid.
5. Isolation of the organism from blood & edematous fluid.

Control:

a) General measures:

1. Isolation and treatment of the affected animals.
2. Close animal markets, cattle show. Etc.
3. Burning or burial of dead animals.
4. Proper disposal of contaminated feed and water.
5. Disinfection of cattle shed.
6. Avoid long distance transportation and exposure to extreme weather.

b) Vaccination

Vaccination should be given through subcut every year before monsoon

Treatment: Treatment is effective if given in early stage of disease. Immediate consultation of a veterinary doctor for start with specific treatment.

Vaccine:

1. Vaccine- WHO definition-

A vaccine is a biological preparation that improves immunity to a particular disease. A vaccine typically contains an agent that resembles a disease-causing microorganism, and is often made from weakened or killed forms of the microbe, its toxins or one of its surface proteins. The agent stimulates the body's immune system to recognize the agent as foreign, destroy it, and "remember" it, so that the immune system can more easily recognize and destroy any of these microorganisms that it later encounters.

Vaccination is the most effective method of preventing infectious diseases; widespread immunity due to vaccination is largely responsible for the world-wide eradication of smallpox and the restriction of diseases such as polio, measles, and tetanus from much of the world.

2. Objective of vaccination:

- To improve the health and welfare of companion animals, increase production of livestock in a cost-effective manner, and prevent animal-to-human transmission from both domestic animals and wildlife.
- These veterinary vaccines have had, and continue to have, a major impact not only on animal health and production but also on human health through increasing safe food supplies and preventing animal-to-human transmission of infectious diseases.

3. Importance of vaccination

- Control of diseases of companion animals- There is a spread of disease from one infected animal to another healthy animal. Vaccination prevents occurrence of disease by developing immunity against the diseases. Hence controls the spread of the disease.
- Control of emerging and exotic diseases of animals and people: With the increase in connectivity the world is becoming smaller gradually. Many new diseases like Japanese encephlytis are entering our country though the place of origin is in different country. By vaccinating the people and animal coming to our country spread of disease can be controlled.
- Control of zoonotic diseases: There are diseases which spread from animal to human beings and vice versa. By vaccinating the disease spread is controlled.
- Safe and efficient food production: The animal which has been timely vaccinated as per schedule is safe for meat consumption purpose.
- Reduction in the need for antibiotics: The animal vaccinated against bacterial infection is less prone to the disease and hence need for antibiotics for treatment is less.
- Food safety vaccines: There should be a time lag after vaccination of animal during which it should not be slaughtered for meat.

4. Precautions for vaccination program

Immunization program may not be effective and there may be break down of immunity if the execution of vaccination work is not done properly-

- Store the vaccine in refrigerator: It is done to maintain the potency of the vaccine.
- Purchase the standard and quality vaccine: The vaccine made by standard company certified for quality parameters should be purchased.

- Procure the required quantity of vaccine: The optimum quantity of vaccine should be purchased as it should be consumed before the expiry period and number should be sufficient to cover the entire herd.
- Sterilize the needle, syringe and other equipments: The injection used for vaccination should be sterilized.
- Dissolve the vaccine in clean container: Oral vaccine should be given in the clean container.
- Do not give two different vaccines on the same day.
- Do not use the date expiry vaccine.
- Monitor the nutritional status of the animals and birds: The animal or bird should have nutritious diet to produce immunity against the vaccination.
- Give the dewormer before vaccination: Dewormer should be given as per schedule (atleast one week before) to make vaccine more effective.
- Use the exact route as indicated: The route prescribed in vaccine only should be used.
- Do not use chlorinated water, boiled water or alcohol to sterilize the syringe and needle.

5. Common Reasons for Vaccination Failure

- Lack of maintenance of cold chain from the time of manufacture till vaccination.
- Poor immune response in weak and improperly fed animals.
- Lack of herd immunity due to only a few animals being vaccinated.
- Poor quality of vaccine - Quality will deteriorate if repeatedly thawed and cooled.
- Low efficiency or ineffective vaccine – May occur in case of strain variation (e.g. FMD).

6. Vaccination schedule

A. Cattle and Buffaloes

S.no	Name of Disease	Age at first dose	Booster dose	Subsequent dose(s)
1	Foot and Mouth Disease (FMD)	4 months and above	1 month after first dose	Six monthly
2	Haemorrhagic Septicaemia (HS)	6 months and above	-	Annually in endemic areas.
3	Black Quarter (BQ)	6 months and above	-	Annually in endemic areas.
4	Brucellosis	4-8 months of age (Only female calves)	-	Once in a lifetime
5	Theileriosis	3 months of age and above	-	Once in a lifetime. Only required for crossbred and exotic cattle.
6	Anthrax	4 months and above	-	Annually in endemic areas.
7	IBR	3 months and above	1 month after first dose	Six monthly (vaccine presently not produced in India)
8	Rabies (Post bite therapy only)	Immediately after suspected bite.	4th day	7, 14, 28 and 90 (optional) days after first dose.

B. Vaccine for sheep and goat				
Sl No.	Name of disease	Month of vaccination/age	Repeat Dose	Remarks
1	Enterotoxaemia	February	December	Multi component
2	FMD	June		Poly valent
3	H.S.	July		Oil adjuvant
4	Pox	September		Pox vaccine
	PPR	4 months	3years	

i. **Vaccination in poultry:**

Vaccination Schedule for Layer

Vaccination Programme for Layers					
SL.	Age	Disease and vaccine	Vaccine	Administration	Dose/ Remarks
1	0-2 days	Marek's disease	Marek's vaccine "HVT strain"	Subcutaneous (S/c) at hatchery	
2	5th- 10th day	Ranikhet Disease	F1 or Lasota strain	Nasal/ Occular or oral drop or drinking water	2 drop
3	12th-15th days	Infectious Bursal Disease	Gumboro disease (Live) vaccine	Oral drop or drinking water	
4	4th-5th week	Fowl pox	Fowl pox vaccine (BM strain)	Intramuscular (I/M)	
5	5th-7th week	Ranikhet Disease	R2B strain	Intramuscular (I/M)	0.5 ml
6	7th-8th week	Gumboro disease	Gumboro disease (Live) vaccine	Oral drop or drinking water	only in area of outbreak pron
7	13th-15th week	Infectious Brochitis	IB vaccine	Oral drop or drinking water	
8	14th -15th week	Fowl pox	Fowl pox vaccine (BM strain)	Intramuscular (I/M)	
9	15th-18th week	Egg drop syndrom	Egg drop syndrom vaccine (76 killed adjuvanated)	Intramuscular (I/M)	
10	16th-18th week	Ranikhet Disease	R2B strain	Intramuscular (I/M)	

ii. Vaccination Schedule for Broiler

BROILER					
SL. No	Age	Disease and vaccine	Vaccine	Administration	Dose/ Remarks
1	0-2 day	Marek's disease	Marek's vaccine "HVT strain"	Subcutaneous (S/c) at hatchery	
2	5th- 7th day	Ranikhet Disease	F1 or Lasota strain	Nasal/ Ocular or oral drop or drinking water	2 drop
3	12th-15th days	Infectious Bursal Disease (IBD)	Gumboro disease (Live) vaccine	Oral drop or drinking water	
4	3rd-4th week	Ranikhet Disease	F1 or Lasota strain (Repeat)	Nasal/ Ocular or oral drop or drinking water	2 drops
5	4th-5th week	Infectious Brochitis	IB vaccine	Eye drop or drinking water	

37. HANDLING AND RESTRAINING PIGS

By the time they are weaned young pigs are too big to be easily lifted. Older pigs can be moved from place to place using pig boards.

Pigs are very clever and quick to learn. They can be dangerous.

Learning objectives

After studying this unit you should be able to:

1. Safely handle young pigs.
2. Handle older pigs.
3. Restrain the pig.

HANDLING THE YOUNG PIG

Piglets can be caught from behind and held by grasping the hind leg just above the hock. The small piglet can then be lifted by placing the other hand under the chest and lifting the animal. When holding the piglet always support its weight against you. By the time the piglet is weaned it will be too heavy to lift.

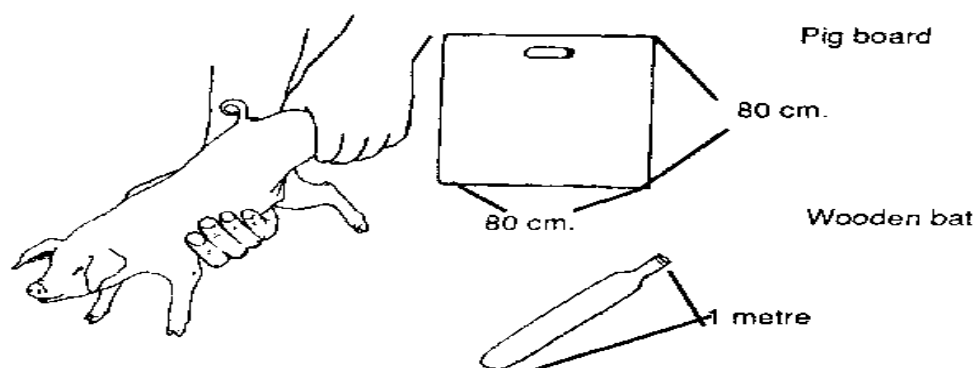

FIGURE 59: HANDLING THE YOUNG PIG

HANDLING THE OLDER PIG

Pigs will naturally head for a gap (or opening) when you approach them or try to catch them. You can use this habit to make the pig go where you want it to. If two pig boards (wooden boards 0.8m square) are placed either side of the pig's head it will move forward in the direction the handlers want it to go. As the animal gets older it can be trained to move under the control of one handler who uses a board and a wooden bat about 1 m long.

The handler always keeps the pig board between himself and the pig. If several people try to drive a pig it can turn and charge between them.

RESTRAINING A PIG

You can restrain a pig by holding it with ropes against a wall or fence. Large pigs can be easily restrained with a rope or wire loop around the snout.

TEETH CLIPPING IN YOUNG PIGS

The teeth of the young pig are clipped as soon as possible after birth. The piglet is born with 8 teeth.

If the teeth are not clipped the sow's (mother) udder may be injured by the suckling piglets. Removal of the teeth also prevents the young pigs injuring themselves while fighting or playing.

Learning objectives

After studying this unit you should be able to:

1. Understand why the teeth of young pigs are clipped.
2. Carry out teeth clipping on the piglet as soon as possible after its birth.
3. Handle the sow and her young with as little stress as possible to both.

WHY ARE THE TEETH OF PIGLETS CLIPPED?

Piglets bite the sow (mother) in their fight to get hold of one of her teats and suckle. The pain caused by this disturbs the sow causing her to get up and prevents her young from feeding. The cuts to the sow's udder also allow germs to infect the udder. In their fight to grasp the teat and suckle piglets will also bite and injure one another. The simple practice of clipping the teeth as soon as possible after birth prevents these problems.

WHEN TO CLIP THE TEETH

The piglet's teeth should be cut as soon as possible after its birth. The teeth can be cut when the pig is only 15 minutes old. The sow and her young should be separated for as short a time as possible. In order to clip the teeth you will need either a pair of tooth clippers, or pliers or forceps.

You will need someone to help you separate the sow and her young. You will also need a box containing bedding and a clean empty pen.

CLIPPING THE TEETH

- If the sow is not tied up separate her from her young and place her in another pen. Take care as the sow with a litter can be dangerous.
- Corner the young pigs and keep them together or place them in a box.
- Hold the head and press the corner of the piglet's mouth so that the jaws open.
- Place the clippers on either side of one pair of teeth making sure that the tongue is not in the way. Tilt the head so that the pieces of the teeth will fall out of the mouth.
- Cut the teeth as close as possible to the gums.
- Clean the clippers before using them on another piglet. Operate on the rest of the litter and when you have finished put the piglets back with their mother immediately. Keep young piglets warm.

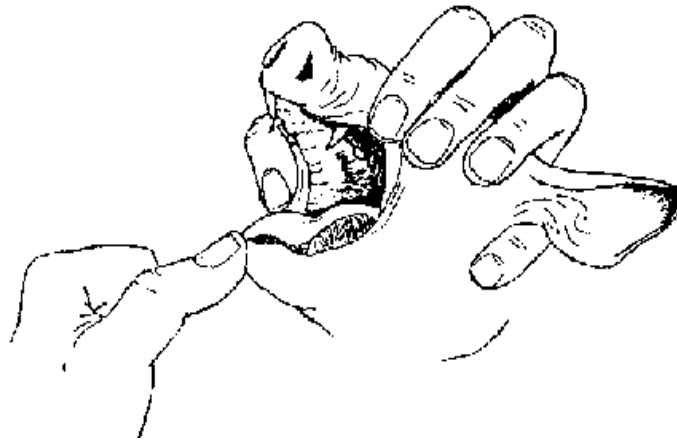

FIGURE 60: CLIPPING THE TEETH

INTERNAL PARASITES OF PIGS

Pigs can be infected with a number of different roundworms. These can result in poor weight gain in adults. In young pigs infection with roundworms can cause diarrhea, weight loss, lung problems and death. Worms from pigs can cause disease in human.

Learning objectives

After studying this unit you should know:

1. The problems caused by roundworms in pigs.

2. How to treat and control roundworm infections of the pig.
3. Problems caused in human by pig parasites.

ROUNDWORM INFECTIONS OF THE PIG

Pigs can be infected with a number of different roundworms. People who keep pigs can notice large roundworms, 25 - 40 cm long in the animals' dung. In pigs 2 to 5 months old the worms cause diarrhea, weight loss and lung problems. The young worm lives in the liver and lungs before passing into the intestine. The damage to the lungs can allow germs to attack and cause coughing and lung infections. The young pig can die.

The worm in the liver of young and adult pigs causes white spots (milk spot) to develop. Such a liver should not be eaten by humans.

TREATMENT AND CONTROL OF ROUNDWORMS

Infected pigs are easily treated by dosing with a suitable treatment, e.g. piperazine. The pregnant sow should be treated before giving birth or she will pass on infection to her litter. One female worm will produce a million eggs a day which pass out in the dung. These eggs infect new hosts and can stay in the ground or the pigsty for up to 5 years.

The pigsty, shelter or pen should be cleaned out and the walls and floor treated with caustic soda which is left for 2 - 3 days before washing it off. If infected pigs have been kept out in a field the land should be ploughed and used for a crop, or as grazing for other animals, before pigs are put back on it.

PROBLEMS CAUSED BY PIG PARASITES IN HUMANS

Pigs can be infected with a parasitic worm called *Trichinella*. The adult worm lives in the intestine while young worms are found in the muscles (meat). It does not appear to be a problem to the pig. Any animal which eats the pig meat can be infected with the worm.

Pigs can be infected with *Trichinella* from eating rats which have the infection. Pigs will also be infected from contaminated meat so all meat fed to the animals (e.g. in swill) should be thoroughly cooked. Thorough cooking of pork will also kill the worm. If humans eat undercooked pig meat from an animal infected with this parasite they will become infected too.

If a pig is left to wander around it may eat plants contaminated with human faeces. In this way, the pig meat can become infected with a tapeworm from humans. If the meat of that pig is not properly cooked people who eat it can become infected with the pork tapeworm.

Do not allow pigs to wander around free.

SKIN INFECTIONS OF PIGS

Learning objectives

1. Recognize mange and lice infections of pigs.
2. Know how to control and treat mange and lice infections of the pig.
3. Recognize erysipelas in pigs.
4. Know how to control and treat tick infections of pigs.

MANGE IN PIGS

Mange is caused by infection with mites and results in thickening and crusting of the skin. The activity of the mites burrowing into the skin makes the pig scratch and the wounds caused can become infected with germs. Mange occurs around the head, ears, legs and tail but will spread over the body if not treated.

Mange is controlled by spraying, dipping or painting the infected areas with a suitable preparation. The pen and shelter should also be thoroughly cleaned out and washed down. Treatment should be repeated after 2 weeks.

After working with mangey pigs wash your hands thoroughly and wash clothing too.

If you have a mange problem in your community which you cannot stop you will need to ask for veterinary advice. To identify the mite causing the problem the veterinarian will need skin scrapings from infected animals. Identifying the mite will allow him to decide what treatment you should use.

LICE AND TICK INFECTIONS

Pigs can suffer from infection with dark colored lice which can be seen on the animal's body. The lice feed on the skin and irritate the pig which will scratch and can cause wounds which become infected. Treatment involves spraying with coumaphos and cleaning the areas where the animals are kept.

Pigs can be attacked by some ticks which take blood. The ticks may carry other infections to the animals. Treatment can be carried out by spraying with a suitable compound or by removing the ticks by hand or by touching them with kerosene or a lighted cigarette. Affected pens should be thoroughly cleaned.

ERYSIPELAS (DIAMOND SKIN DISEASE)

Erysipelas or diamond skin disease of pigs can kill the animals. This is an infection of the pig's body which produces recognizable discoloration on the pig's body. These are reddish diamond-shaped areas on the skin or the animal may have a purplish color to the head and ears. Pigs with erysipelas have a high temperature and do not feed; they squeal if touched. The animal can die from an acute infection or in chronic cases the animal survives but suffers from swollen joints and lameness.

Erysipelas is treated by using the antibiotic penicillin. Animals can be vaccinated against the disease.

HEAT (OESTRUS) IN THE SOW

The female pig (sow) is ready to breed (reaches puberty) at 5 months of age and will show signs of being in heat. Some slow growing types and animals which are underfed will be older when they reach puberty.

The sow will come into heat every 3 weeks throughout the year if she is not mated.

Learning objectives

After studying this unit you should know:

1. When a female pig is ready for breeding.
2. How often the pig comes into heat.
3. The signs of heat in the pig.
4. How to make the pig come into heat.

WHEN IS THE SOW READY FOR BREEDING?

Most breeds of pig reach puberty at 5 months of age but some, e.g. the Chinese pig, come into heat for the first time at 3 months of age when they have enough good feed and water.

The pig should not be used for breeding when she comes into heat for the first time. It is wiser to allow her to grow for another month before using her for breeding. She will then be better able to carry and suckle a good litter of young. Only sows with 14 teats should be used for breeding so that all her litter can feed.

If the pig is not mated she will come into heat every 21 days, providing she has enough feed and water.

SIGNS OF HEAT

The female pig coming into heat is restless and may not eat. The vulva becomes pink and swollen. When the pig is pressed hard with the hands on either side of her back she will stand still, showing she is ready to accept the male.



FIGURE 61: SIGNS OF HEAT IN PIGS

The sow will be in heat for 8 to 36 hours.

HOW TO BRING THE SOW INTO HEAT

Healthy, well fed sows can be brought into heat so that breeding can be controlled.

Putting a sow which is in heat in with those which are not in heat will make some of the latter come into heat. A better method is to pen sows next to a boar so that they can see and smell him. The sows will come into heat especially if the boar is old and smelly.

Remember that failure to come into heat can be the result of poor or too little feed or a health problem in the sow.

PREGNANCY AND FARROWING (GIVING BIRTH)

Pregnancy lasts for 3 months 3 weeks and 3 days.

A well-fed sow will produce at least 10 piglets (litter) from each pregnancy and may have 2 litters each year.

Learning objectives

After studying this unit you should be able to:

1. Care for the pregnant sow.
2. Recognize when the sow is about to farrow (give birth).
3. Recognize normal farrowing.
4. Recognize when the sow has problems and be able to assist.

CARE OF THE PREGNANT SOW

If the sow shows no sign of being in heat 3 weeks after mating she is pregnant. The pregnancy will last about 3 months 3 weeks and 3 days. During the pregnancy, the sow will need plenty of feed high in nutrients and will especially need more feed towards the end of the pregnancy. She should be given some feed high in nutrients e.g. grain and green stuffs every day. Giving the sow access to clean soil or grass with roots from land where no pigs have been kept will allow her to get the minerals she needs.

Give the sow plenty of clean bedding when birth is close.

SIGNS THAT THE PIG IS READY TO FARROW

The sow becomes restless and starts to make a nest within 24 hours of giving birth. The teat will produce milk when gently squeezed.

Blood stained fluid may be passed from the vagina 1 to 2 hours before birth begins and if small greenish pellets appear the first piglet will appear within an hour.

Gently rubbing the udder will make the sow relax and lie on her side in the position to give birth.

NORMAL FARROWING

Farrowing is a natural process and the sow will usually need no help. Once the first piglet is born the others, and the afterbirth, will quickly follow. Farrowing should be completed within 2 to 3 hours. The navel cord will break (you do not need to cut it) and the piglet will immediately search for a teat and milk. If the navel bleeds, tie it tightly with a clean string or cord.

WHEN AND HOW TO HELP IN FARROWING

If the sow shows all the signs of farrowing but she has not produced a piglet and is pawing with a hind leg, or if 45 minutes has passed since the first piglet appeared and there is no sign of the second you will have to help the sow.

- Wash your hands and arms with warm water and soap and scrub under your fingernails.
- Wash the region of the vulva.
- Make your hands soapy or put olive or sunflower oil on your hands.
- Put your hand into the vagina and feel for the piglet or matter causing the blockage and try to remove it.

Clear the piglet's mouth and nose of mucous and if it is not breathing you can slap it to encourage it to breath. Gently rub the piglet dry and put its mouth on a teat.

CARE OF THE SOW AND PIGLET

A healthy well-fed sow will be able to rear at least 20 piglets each year.

If the sow has too many piglets to feed, or if a sow dies, the young can be fostered or hand reared.

Learning objectives

After studying this unit you should:

1. Know if the sow is a good mother.
2. Judge if the piglets are feeding well.
3. Know how to foster piglets.
4. Know how to hand-rear piglets.

HOW GOOD A MOTHER IS THE SOW?

A sow should have at least fourteen teats which should be long and thin enough for the piglet to grasp. Each piglet suckles from its own teat feeding every hour. The first born and stronger piglets use the teats nearest the sow's head which produce most milk. As a sow gets older and has more litters the teats can become large making it difficult for the piglet to suckle. Sometimes the back teats do not produce much milk. A sow may be unable to feed all her young and is no longer fit for breeding.

A sow can suffer from mastitis which may develop as a result of damage to the teats caused by the piglet's teeth. Clipping the teeth of the piglet prevents cuts to the teats.

ARE THE YOUNG FEEDING WELL?

Not all of the piglets will grow at the same rate, some will be born smaller than the others. They fight for feed and the smaller piglets will grow at a slower rate and even die. You can expect to see a difference in weight gain and growth between the members of any litter, but if all of the piglets do not grow well and there are no obvious signs of disease you should suspect poor milk production by the mother. This is often the case with old sows.

It can become necessary to foster the piglets, i.e. put them with a different sow for feeding.

FOSTERING PIGLETS

It is essential for all piglets to take colostrum from the mother. They will take the first feed within 1 hour of being born.

If a sow dies during farrowing her litter can be fostered to another. The orphans should be mixed in with the sow's own litter so that she will accept them. However, the foster mother will not be able to feed both litters at the same time and it will be necessary to use several foster mothers to feed the orphans.

HAND REARING PIGLETS

A sow may die and there is no foster mother available. The litter can be reared by hand feeding. To hand rear a litter the following will be needed:

- Feeding bottles and teats (nipples) which are thoroughly cleaned between each feeding.
- A clean dry box containing clean bedding for the newborn piglets which can be kept in a warm place.
- Regular feeds must be given at intervals of 1 to 2 hours.
- Cow's colostrum is the best substitute for the sow's colostrum and after 3 to 4 days the piglets can be given milk.

CASTRATING PIGLETS

Castration, or the removal of the testicles, is carried out on the male pig which is not needed for breeding.

If the blood vessel to the testicle is cut straight through, or pulled heavy bleeding can occur. Bleeding is reduced by scraping the twisted blood vessel with a knife until it is cut through.

Castrated animals are quieter and easy to handle.

The castrated animal is fatter and produces meat which does not have a strong smell.

Learning objectives

After studying this unit you should know:

1. Why male pigs are castrated.
2. When is castration carried out.
3. How to restrain pigs for castration.
4. How to castrate animals.

WHY ARE PIGS CASTRATED?

Male pigs (boars) can fight causing injury to one another. Castrated pigs are quieter and easier to handle. Castrating the pig makes it put on more fat and the meat does not have a strong piggy smell. Young pigs should be castrated at 2 to 3 weeks of age.

RESTRAINING THE PIG FOR CASTRATION

You will need someone to hold the piglet for castration. The pig should be held by the hind legs with its head down and its body should be firmly held between the handler's knees.

Castration cuts

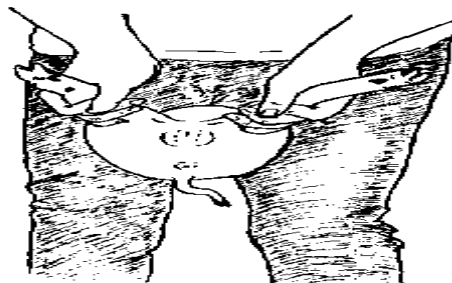

FIGURE 62: CASTRATION CUTS IN PIGS

You will need a very sharp, clean knife, scalpel or razor blade. Remove the sow from the litter and if possible put her where she cannot see or hear them.

- Clean the scrotum with warm water and soap and dry it.
- Move the testicle into the scrotum with your finger and then firmly grip the scrotum below the testicle between your thumb and index finger.
- Make a cut 1 - 2 cm long in the bottom of the scrotum. The testicle should pop out through the cut.
- Pull the testicle out of the scrotum and cut through the white cord *leaving the red blood vessel uncut.*
- Pull the testicle out slightly further and twist it around several times before *cutting the twisted blood vessel by scraping up and down with the knife.* This helps to reduce bleeding. *Do not pull to break the vessel.*
- Do not put your fingers in the scrotum. Apply either tincture of iodine, gentian violet, Dettol or an antibiotic powder or a sulpha powder to the castration wound. Remove the second testicle in the same way.

Put the piglets and their mother on clean bedding. Watch piglets for signs of infection in the wound for the next week. Infected castration wounds swell, piglets do not want to walk or are lame.

FEEDING PIGS

The pig is omnivorous and can eat meat and plants. The digestive system of the pig can also use bulky feeds containing a lot of roughage.

Pigs must have plenty of clean, fresh water every day.

Learning objectives

After studying this unit you should know:

1. What types of feed to give pigs.
2. How often you will need to feed pigs.
3. How and when to wean piglets.

THE TYPES OF FEED TO GIVE TO PIGS

Pigs will eat anything. They will eat grass and all types of plants. They can be kept in a well fenced field where they will eat all of the plants and grass there. The pig not only eats the green parts of plants but will also dig into the ground and eat all the roots. A pig with a nose ring cannot root up plants.

The pig's eating habit can be used by man. If a pig is put in a field it will clear it, plough it and fertilize it.

Pig's will grow and get fat more quickly if they are fed concentrate feed. Grain which has been well ground into meal is a good feed. Waste vegetables and household scraps can also be given to pigs. Household scraps, especially those containing meat, must be well boiled (pig swill) before being given to the pig.

The pig must always be able to drink fresh clean water. A sow with young will need 20 - 30 litres of water a day.

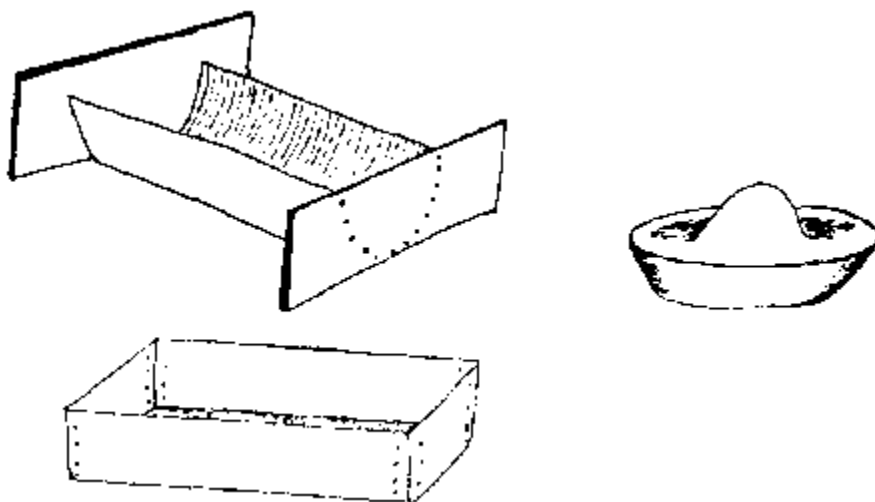

HOW OFTEN WILL A PIG NEED FEEDING?

Pigs can be kept in a sty when they will need to be fed twice a day with one feed in the morning and one in the evening. Pigs in the field can be offered meal once a day or given extra feed, e.g. vegetable waste or swill, when it is available.

WEANING

Piglets show an interest in solid feed when they are 1 or 2 weeks old. They can be offered a handful of cereal, sugar or powdered milk to start with. Piglets will take milk from the mother until they are about 7 weeks old. They will gradually take less milk and eat more solid feed until they are weaned. Piglets in the

field will naturally start to eat solid feed but it must be offered to those that are housed. The young animals need to be gradually given new feed to avoid digestive problems.

Remember that a pig should rush to eat its feed. Lack of interest in feed is a sign of ill health and you will need to look at the animal to determine the cause of health problems.

HOUSING FOR PIGS

Pigs can be kept in a field where there is a shelter or they can be kept in a pig sty.

Pigs should not be allowed to wander about free. There will be no control over what they eat or where they go and disease will spread.

Learning objectives

After studying this unit you should know:

1. How to keep pigs in a field.
2. The types of housing (buildings and pens) for pigs.
3. Housing piglets.

KEEPING PIGS IN A FIELD

Wild pigs live amongst bushes and the roots of trees. When pigs are kept with access to a warm, low area to lie and sleep in, as they would in the wild, the pigs do better. Pigs can be kept in a field where they can feed on grasses and plants. If pigs are kept this way, the field must be surrounded by either a strong fence or a wall. Pigs will push their way out of a field if the fence is not strong enough. The animals are given shelters called pig arks to sleep in. These can be made of wood or metal sheets and should contain bedding. The arks can be moved to fresh ground when necessary.

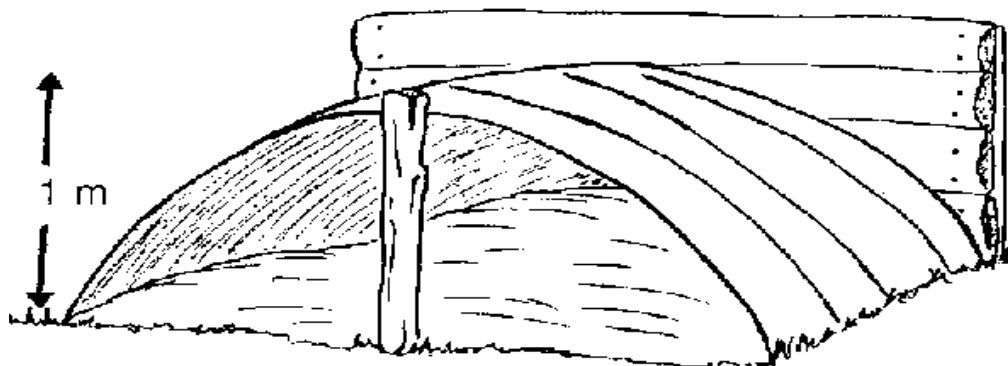

FIGURE 63: HOUSING AND PENS FOR PIGS

HOUSING AND PENS FOR PIGS

Pigs can be kept alone or in small groups in a pig sty, a concrete or solid floored pen with a low shelter.

When building a sty you should choose an area which is never flooded in the rainy season. It should not be too near to houses so that smells and flies are a nuisance. The floor should be concrete and sloping away from the sleeping area so that urine flows out and away. The concrete floor should be laid on a good foundation and will need to be 5 - 6 cm thick. If the concrete is too thin and cracks, the pigs will soon start to dig it up. An earthen floor cannot be kept clean and will lead to problems with parasites and other diseases. The walls of the sty need to be fairly smooth so that they can be kept clean. Cracks in the walls will allow dirt and germs to accumulate.

The animals should be given plenty of bedding in the shelter. Pigs will always dung away from their sleeping and feeding areas. The dung can be removed every day allowing the pen to be kept clean and avoiding the buildup of waste and smells.

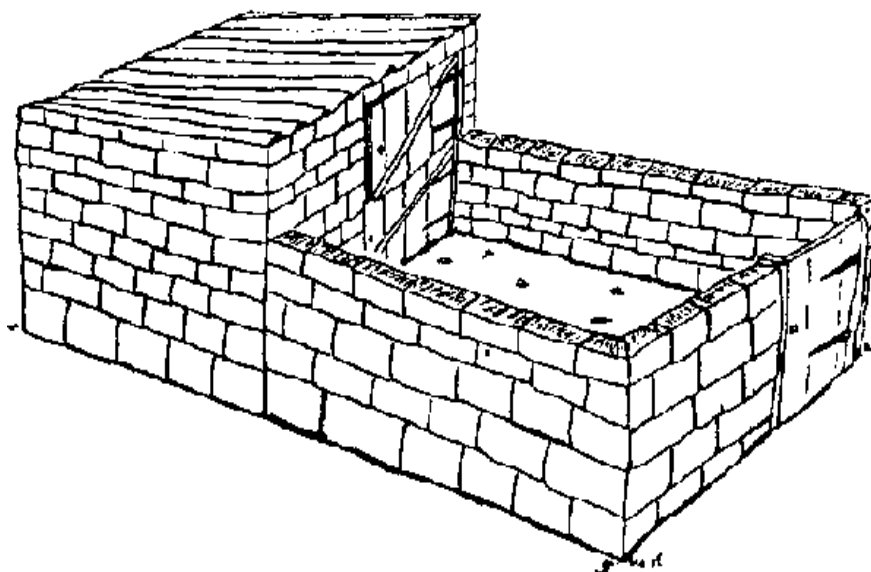

FIGURE 64: HOUSING FOR PIGLETS

HOUSING FOR PIGLETS

Breeding sows and their litters can be kept in sties or using the open field system. Plenty of bedding should be given to help keep the young animals warm and it must be changed frequently. If a litter is raised in a sty, the sty should be thoroughly cleaned and scrubbed out after the litter has been weaned and moved elsewhere. If a litter is raised in the field, the shelter should be moved to a new site for the next litter to avoid disease problems, especially from parasitic worms, developing.

Whatever the housing method used piglets should have access to a warm area which the sow cannot reach. This is called a creep and piglets can be given feed here and can lie down without the risk of the mother lying on top of them. The sow is prevented from entering the creep by placing a temporary wall of boards or strong rails across part of the shelter. The bottom rail is about 30 cm from the ground allowing the small piglets to pass under it.

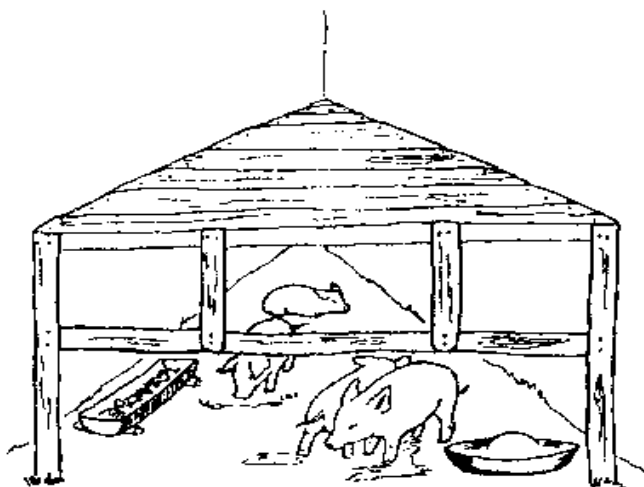

FIGURE 65: HOUSING FOR PIGLETS (B)

Do not allow pigs to wander free around the community. This results in the spread of disease among the animals and also between them and people.

EAR TAGGING OR NOTCHING (IDENTIFICATION)

Ear tagging or notching allows you to identify your pigs by sight. Notching is easy to do and costs nothing. You can identify up to 121 pigs in this way.

This method can be used to identify other animals, e.g. sheep and goats.

Learning objectives

After studying this unit you should know:

1. Why do we identify animals.
2. How to notch the ear.
3. Reading the number of the pig.

WHY WE NEED TO IDENTIFY ANIMALS

If you have a few pigs or other animals, identifying them is no problem. You will be able to identify them by sight and may well have given them a name. You will need some way to identify a large number of animals especially if you are going to keep records. There are many ways to identify animals including numbered collars, tattoos, and plastic tags. Notching the ear is easy and is the cheapest way.

NOTCHING THE EAR

A V-shaped notch can be cut out of the edge of the ear using a pair of clean scissors. Make the notch a few centimeters deep so in future you will be able to read it from a distance.

The notches on the left ear are for single numbers and on the right ear the notches are for tens.

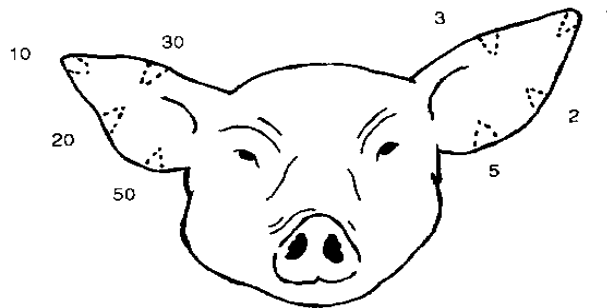

FIGURE 66: NOTCHING THE EAR

RECORDING THE NUMBER OF THE PIG

Look at the notches on the right and the left ears then add up the number on each ear to give the number of the animal.

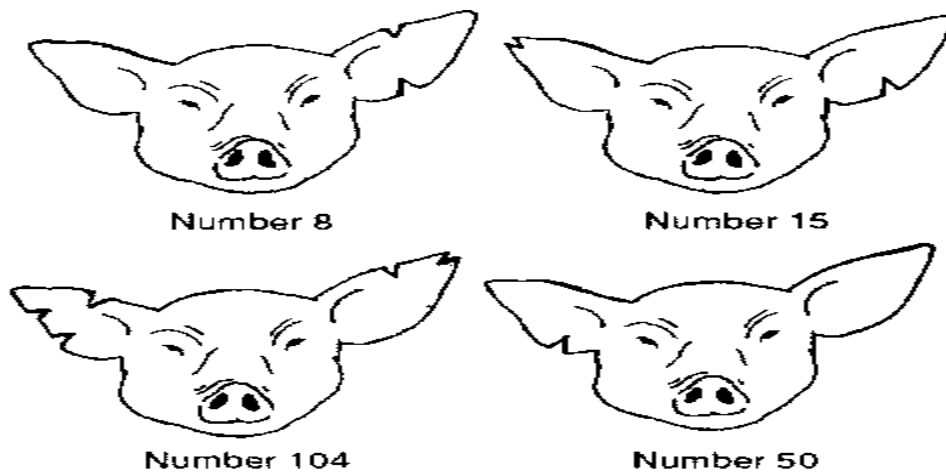

FIGURE 67: RECORDING THE NUMBER OF THE PIG

38. KEEPING CHICKENS AND DUCKS

It is not a good practice to allow chickens, ducks and other birds to freely wander around the community to feed and drink whatever they can find.

Providing shelter, food and clean water to these birds will result in more meat and eggs.

Birds can easily become sick and some diseases kill many birds. Veterinary advice on vaccinations to stop diseases is essential.

Learning objectives

When you have studied this unit you should know:

1. Traditional ways of keeping birds.
2. Better ways of keeping chickens and ducks.
3. The quality of eggs.
4. Vaccination and veterinary aid for chickens and ducks.

TRADITIONAL WAYS OF KEEPING BIRDS

Many communities keep birds to provide meat and eggs for feasts, weddings and other social activities. Sometimes birds are sold for the extra money needed for urgent medicines or food. Many people in the community may keep birds but with limited good results. This can be because:

- Birds are not fed well, but are left to pick up what food they can find on the roads, and to drink dirty water.
- They are not provided with shelter (housing) and can become the victims of cold, rain, foxes and other predators.
- The types of birds (breeds) kept in the community are small birds or those which do not lay large numbers of eggs.

Because of the way they are kept most of the young die and very few birds reach the age of one year. The birds that do survive are small and produce little meat. Many birds must be killed to provide sufficient amounts of meat and little money is obtained by selling them.

BETTER WAYS OF KEEPING CHICKENS AND DUCKS

You can improve the amount of meat and eggs you get from birds by:

- Keeping better breeds (types) of birds which are bigger and lay more eggs.
- Improving the quality of the birds you have by mating them with better quality males.
- Provide housing for birds and good feed and water.

You should try to find out which breeds are available and try to obtain birds which are bigger, produce more meat, and which lay more eggs. You should encourage the community to start to keep these birds or at least to use some to improve the birds they have. There are several ways of introducing better quality birds into the community's flocks:

- Buy male birds of the better breed to mate with females you have.
- Buy day old chicks from the better breed and rear them.
- Buy some birds at 2 to 3 months of age (this is the best way).

THE QUALITY OF EGGS

Chicken eggs will stay fresh longer than the eggs of a duck. Eggs should be kept in a cool place. If placed in a fridge the chicken eggs will stay fresh for 3 weeks while those of the duck must be used within 10 days.

- An egg produced by a female bird kept without a male is called a non fertile egg and will keep fresh for a long time.
- Eggs from a female kept with a male bird are alive and the young chick will start to grow in them if they are kept in a warm place.
- To check eggs hold them against a light or the sun, or candle them.

THE FERTILITY OF THE EGG

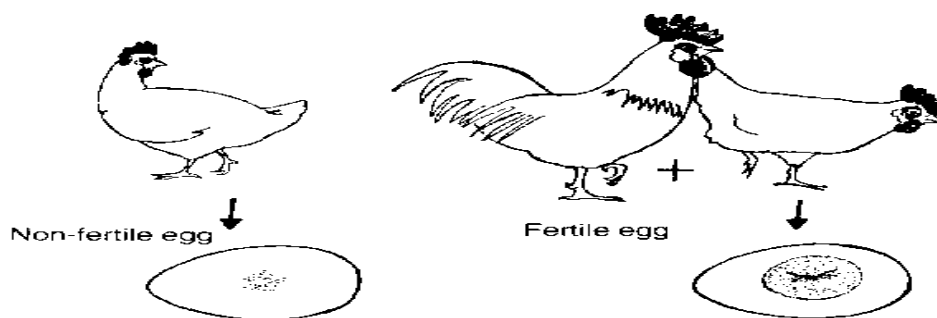

FIGURE 68: THE FERTILITY OF THE EGG

Eggs should be cleaned before they are sold or used. Wipe them with a damp cloth but never wash them in warm water. If eggs are placed in a container of cool clean water, bad eggs which cannot be eaten, will float to the top of the water. Good eggs stay at the bottom. When you use eggs, the condition of the yolk (yellow) and the white of the egg, tells you how good the egg is.

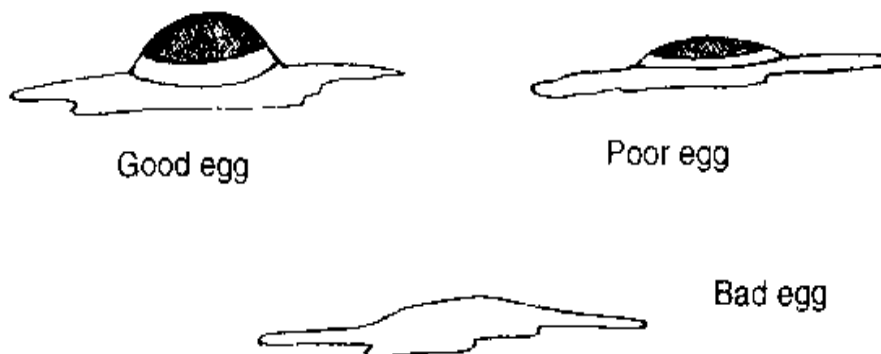

FIGURE 69: THE QUALITY OF EGGS

Take the business of keeping birds seriously. The benefits from keeping them are the same as those gained from keeping other animals.

HOUSING FOR CHICKENS AND DUCKS

If birds are allowed to wander around freely, disease can spread quickly through all the birds kept in the community.

Keeping birds in a closed area and providing them with shelter is the first step towards improving them.

A covered shelter (house) will give chickens and ducks protection from wind, rain, snow and predators such as foxes.

Learning objectives

After studying this unit you should know:

1. Why chickens and ducks should be housed.
2. How many birds can be kept together in a house.
3. How to build a house for chickens.
4. Nesting boxes (for laying eggs).
5. Runs (fenced areas) for birds.
6. The differences between houses for chickens and ducks.

WHY WE HOUSE CHICKENS AND DUCKS

If chickens and ducks are kept in houses:

- They will be protected from the sun, rain, cold and snow.
- They will be protected from other animals such as foxes and birds of prey, from theft and from being killed on the streets.
- Young birds are protected.
- Food and water can be controlled.
- Birds can be prevented from eating bad food or drinking dirty water.
- Nest boxes can be provided to make it easy to collect eggs.
- The spread of disease can be stopped.

HOW MANY BIRDS SHOULD BE KEPT IN A HOUSE

There must be enough space to hold all the birds plus the feed and water containers (troughs). If too many birds are kept together they will start to peck (bite) each other. If any bleed, the problem will become worse, as more birds start to peck. Young birds will need less space than older birds and perches must be provided for chickens to roost on at night.

The ground or floor area required is:

- 50 chickens can be kept in 16 square metres (4m × 4m).
- 1 metre of perch must be provided for every 5 adult chickens.

HOUSING FOR CHICKENS

Suitable housing for chickens should be:

- Built on high ground close to the home of the owner so that he can keep an eye on it.
- The house should be 2 metres high and it is better if the first 50 cm of the walls are brick, stone or concrete while the rest is wood, wood and mesh wire, corrugated iron sheeting or any other suitable materials. Small houses can be made from wood and mesh wire.

RUNS FOR BIRDS (FENCED AREAS)

Every house will need a run for the birds to be able to exercise in, pick up grass, insects etc. The run must be fenced around with wire or other suitable material and if possible should be shaded by some trees. Part can be covered to allow birds to use it on rainy days. If possible the run should be divided into two areas to

keep birds out of one area to allow fresh grass to grow 50 chickens require a 16 square metre house and 500 square metres of run.

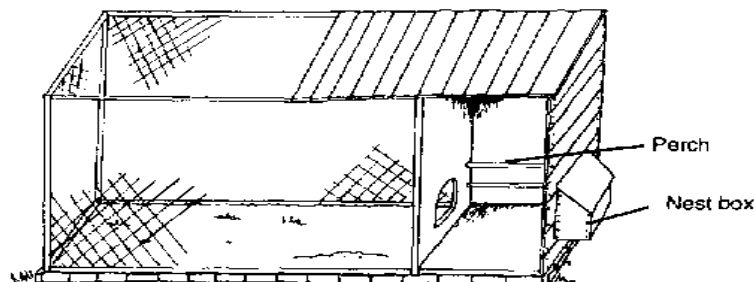

FIGURE 70: RUNS FOR BIRDS (FENCED AREAS)

NESTING BOXES (FOR LAYING EGGS)

Nesting boxes are boxes in which the hen can lay her eggs. You can make them from wood, baskets or pottery. Line them with straw or hay as a nest. Wooden boxes can be built on to the side of the house and opened from the outside to remove the eggs.

HOUSING FOR DUCKS

Housing for chickens can be used for ducks. However if you keep ducks you should remember:

- Ducks do not require perches and nesting boxes will need to be low to allow ducks to use them, or sloping ramps must be placed to allow ducks to get to the boxes.
- You will need to provide ducks with a container of water at least big enough for them to put their heads and necks into the water.

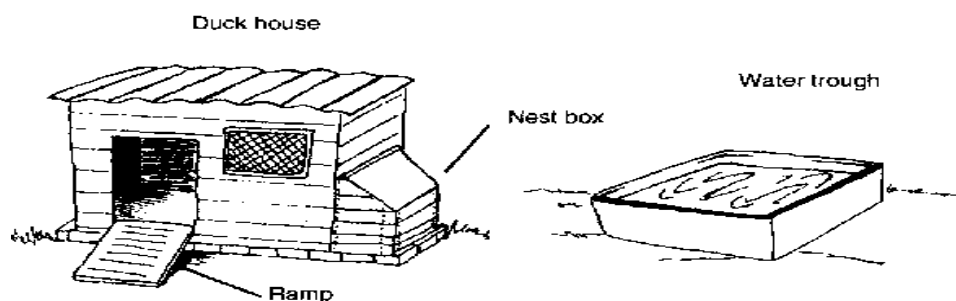

FIGURE 71: HOUSING FOR DUCKS

Laying ducks must be kept in the house each morning until they lay their eggs.

FEEDING CHICKENS AND DUCKS

In order to get good meat and egg production from birds they must be given good feed containing necessary nutrients.

If birds are allowed to wander freely and eat whatever they can find they will not grow properly, will produce little meat and few eggs.

Learning objectives

After studying this unit you should know:

1. The digestive system of birds.
2. What the bird needs in its feed.
3. The different feeds for chickens and ducks
4. Rations for chickens and ducks.
5. How much water birds need.

THE DIGESTIVE SYSTEM OF THE BIRD

The bird has no teeth; food is swallowed whole and goes into the crop where it is stored and mixed with saliva. If you feel the crop you can tell if a bird has been feeding or not.

The feed passes from the crop into the stomach where it mixes with the juices before passing into the roundish, thick walled, muscular organ called the gizzard. The gizzard contains small stones which the bird has eaten to help the gizzard to grind up the food for digestion. Nutrients are absorbed as ground up feed passes along the intestine.

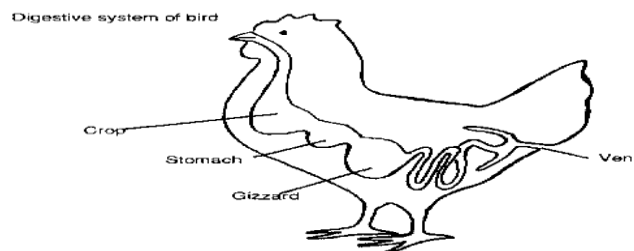

FIGURE 72: DIGESTIVE SYSTEM OF THE BIRD

Birds do not produce liquid urine. Waste from the kidneys forms a thick white material which is mixed with the faeces (droppings). Both are then passed out through the cloaca. The duck produces wetter droppings than the chicken.

WHAT THE BIRD NEEDS IN ITS FEED

Like other animals, birds require carbohydrates, proteins, fats, minerals and vitamins in their feed .

At different times of their life birds will require rations that contain different amounts of carbohydrates, proteins, fats, minerals and vitamins:

- From hatching (1 day old) to 3 months of age, birds will need feed which contains large amounts of protein for body growth.
- When birds are laying eggs minerals are important in producing good eggs.
- Birds kept for meat will need a lot of protein in their feed.

Feed materials for birds

Different feeds are important for the nutrients which they contain.

- Carbohydrates are found in grains which can be fed whole or ground as meal. Birds can be given corn, rice, maize, barley, oats, sorghum, finger and bulrush millet, or bran from rice or other grains.
- Cake from the processing of groundnuts, cottonseed or dates can also provide carbohydrate and protein. Soya bean meal also contains proteins. These types of protein-rich feeds are from plants while animal products such as fish meal, milk powder and dried blood also contain proteins and can be fed to birds.
- Birds must not be given too much animal protein. Not only is it expensive but too much of it may cause some diseases to occur in the animals. Too much fish meal can make eggs taste fishy.
- Fats are found in cottonseed, groundnuts and sunflowers.
- Minerals are in bone meal (ground bone) egg shells and old seashells which can be ground and added to the feed. If cuttlefish bone is available locally it is an excellent source of minerals.
- Vitamins may be supplied by adding green plants to the feed or by adding commercially produced vitamins.

Your veterinary officer will be able to advise you about commercially available vitamin supplements and how to use them.

Your waste food can be fed to birds if it is cut up and boiled. It can then be mixed with meal and fed to the birds.

RATIONS

The ration will change with the requirements of the bird. Young birds need a ration which is rich in protein while laying birds need plenty of minerals. Some examples of rations are given.

Age of Bird	Whole & ground grain	Cake plant/animal	Protein	Minerals
up to 8 weeks	7 parts	2 parts	1 part	0.25 part
8 - 12 weeks	8 parts	1.5 parts	1 part	0.25 part
Laying	8 parts	1.5 parts	0.25 part	0.50 part

TABLE 8: RATION FOR BIRDS

The ration should be thoroughly mixed and then water added until it becomes crumbly (like grain) before feeding it to either chickens or ducks.

For chickens, whole grain can be scattered over the run encouraging birds to scratch as they feed and so take in minerals from the soil. Ducks can be offered whole grain in a trough of water or given dry.

Always clean out unused feed daily. Green vegetables can be hung up in the run to encourage the birds to show an interest and not peck at each other.

WATER

Birds need clean fresh water at all times. Every 4 chickens will need 1 litre of water every day and this will double as the weather becomes hotter.

Ducks need more water than chickens each day. Ducks do better if they have enough water in which to dip their heads and necks.

PROBLEMS CAUSED BY POOR FEED (DEFICIENCIES)

A deficiency means that the bird does not get enough of a particular nutrient. All animals can suffer from deficiency problems but in birds a deficiency very quickly shows signs of:

- *poor health*
- *leg problems*
- *poor feathering*
- *egg production drops*
- *eggs have thin shells*
- *birds easily take infections*

Learning objectives

After studying this unit you should know:

1. Protein deficiency.
2. Problems caused by a lack of minerals.
3. Problems caused by vitamin deficiencies.

PROTEIN DEFICIENCY

If the feed contains too little protein (animal or plant) the birds will become weak and may develop infections. They do not grow well and meat production is badly affected. Egg laying decreases or stops.

MINERAL DEFICIENCIES

Lack of calcium in the feed can cause:

- The bones of the leg to curve making the bird unable to walk properly
- Soft shelled eggs or eggs without shells are laid

If birds lay eggs that have either no shell or a soft shell these eggs will be broken and can be eaten by other birds. If this happens the chicken can develop a habit of eating eggs which then becomes a problem.

To prevent these problems birds must be given plenty of minerals as powdered shell or bone. If birds are allowed to scratch for grain they will take in minerals they need from the soil in the run. A good source of minerals is to feed crushed egg shells to the birds.

PROBLEMS CAUSED BY A LACK OF VITAMINS

If vitamins are not present in the feed then:

- Birds do not grow well, are weak, cannot move properly and the feathers are ruffled.
- Chest problems can occur and birds have nose and eye discharges.
- The toes curl inwards and birds have difficulty in moving.

These problems can be prevented by adding commercially bought vitamins to the feed or providing the birds with green vegetables in addition to the feed. Vitamin deficiencies can cause birds to start feather picking which becomes a problem.

Results of deficiencies

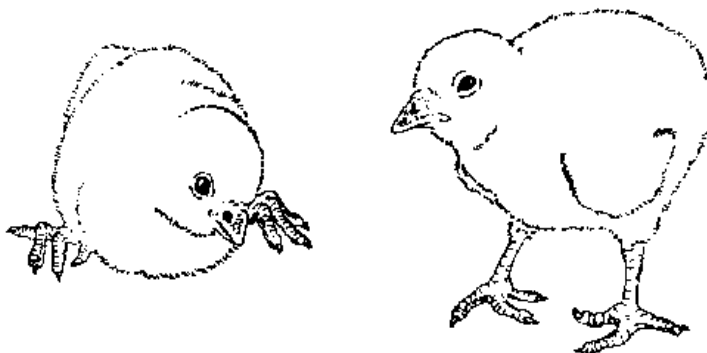

FIGURE 73: PROBLEMS CAUSED BY A LACK OF VITAMINS

INCUBATORS AND BROODERS

Natural incubation by the female bird is the simplest way of hatching eggs. To hatch a large number of eggs you can use a small incubator which is heated by kerosene (paraffin) or electricity.

The condition of the eggs in the incubator can be checked by the method of candling (looking at the eggs with light).

When the young chicks are hatched they are kept in a brooder which has some form of heating and suitable feed and water containers (troughs).

Learning objectives

After studying this unit you should know:

1. How to use an incubator.

2. How to check eggs by candling.
3. How to keep young birds in a brooder.
4. The types of food and water troughs to use.

INCUBATORS (FOR HATCHING EGGS)

If your community has a small incubator you will be able to incubate and hatch eggs with good results if you do the following:

- Choose eggs that are not too small, too large or which have thin or cracked shells.
- Run the incubator for a few days first to check that the temperature is steady at 39.5°C.
- Make sure that the incubator is level and that the temperature of the room where it is kept stays fairly constant (15 - 20°C).
- Make sure that you have enough kerosene or that your electricity supply is reliable.
- Make sure that the thermometer is on a level with the eggs.
- Control the moisture and check that there is always water in the tray inside the incubator.
- Do not touch the eggs with a dirty hand or after you have been handling any kerosene.
- Turn the eggs twice a day for the first 18 days and move them around (as the mother bird would do).

The incubation time for chickens is 21 days and from day 18 the eggs should not be touched and the incubator should not be opened.

Duck eggs need 28 days to incubate and must be sprinkled with water twice a day for the last 14 days.

CANDLING (CHECKING THE EGGS)

Eggs can be incubated and after a lot of care no young hatch because the eggs were not fertile. In order to avoid this happening you need to check the eggs. To do this you will need a small box with an electric light, torch or any other source of light in it. If you hold the egg against the light (or strong sunlight) you will be able to see if it is fertile or not.

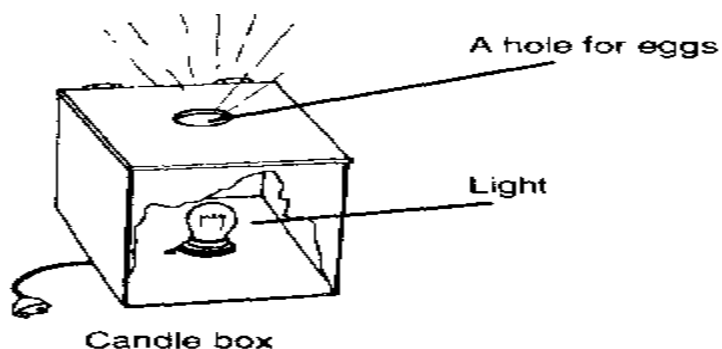

FIGURE 74: CANDLING (CHECKING THE EGGS)

You will need to check eggs:

- Before putting them in the incubator
- 7 days later
- On day 18 of the incubation Period

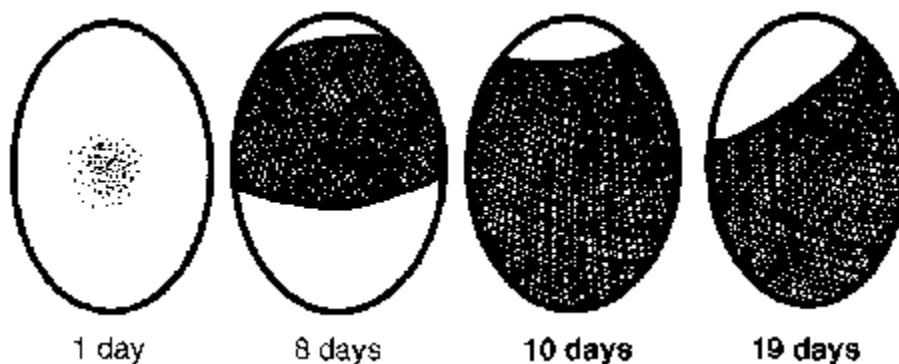

FIGURE 75: QUALITY TESTING OF AN EGG

BROODER (FOR KEEPING VERY YOUNG BIRDS)

If you buy young birds, or hatch them in an incubator, you will need to keep them in a brooder for a few weeks. You can buy a brooder or make your own.

Brooders have a source of heat to replace the heat that the young would have from their mother. In the brooder, they are protected from animals and the weather.

A simple brooder is made from a heavy box or basket and a hurricane lamp (kerosene lamp) as the source of heat. A 1 metre square box will make a brooder for 25 baby birds. The lamp is surrounded with wire

mesh to stop the birds from touching it. Troughs (containers) for feed and water must be placed in the brooder and the birds can be kept in it until they are 4 weeks old.

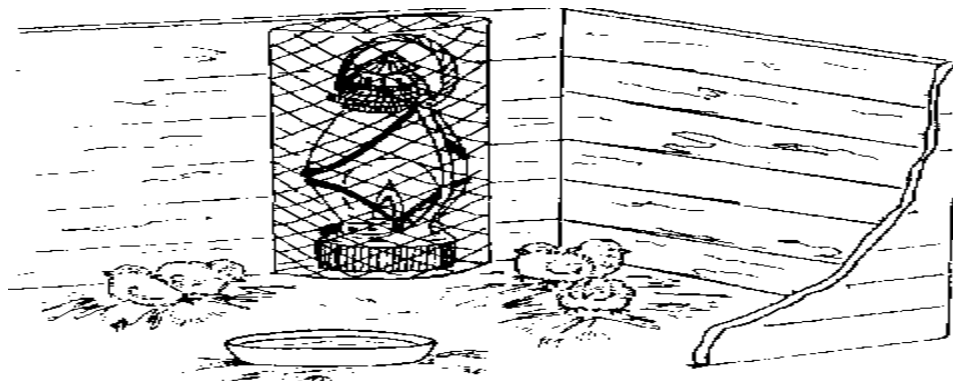

FIGURE 76: BROODER (FOR KEEPING VERY YOUNG BIRDS)

When birds have reached 4 weeks of age they do not need the heat of a lamp and are too big for the brooder. They should be placed in a fenced area (run) with a box covered with hay, straw, paper or cardboard. They can go into the box for warmth when they need it.

WATER TROUGHS (CONTAINERS)

Birds will drink a large amount of water and in hot weather can drink up to half a litre a day. Water troughs must be clean and birds should not be able to get inside them. You can buy troughs or cover a suitable container with wire. Water can also be given using a bottle held over a container.

Ducks need enough water to cover their heads. They can splash water around which can cause problems. Placing the water container for ducks in a wood and wire mesh frame stops the birds reaching the muddy ground.

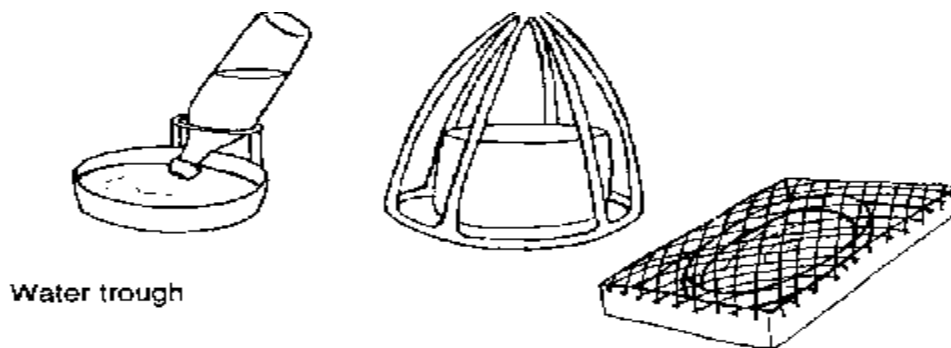

Water trough

FIGURE 77: WATER TROUGHS (CONTAINERS)

FEED TROUGHS (CONTAINERS)

Feed troughs can be bought or made from wood. The troughs must be big enough for all the birds to eat from it.

A good trough for chickens is made from a wooden base with two perches on each side for the birds to stand on to feed. The height of the trough varies with the age of the birds. Across the top of the trough is placed a pole which will turn around if any bird tries to perch on it.

Ducks need shallow troughs or flat containers for feed.

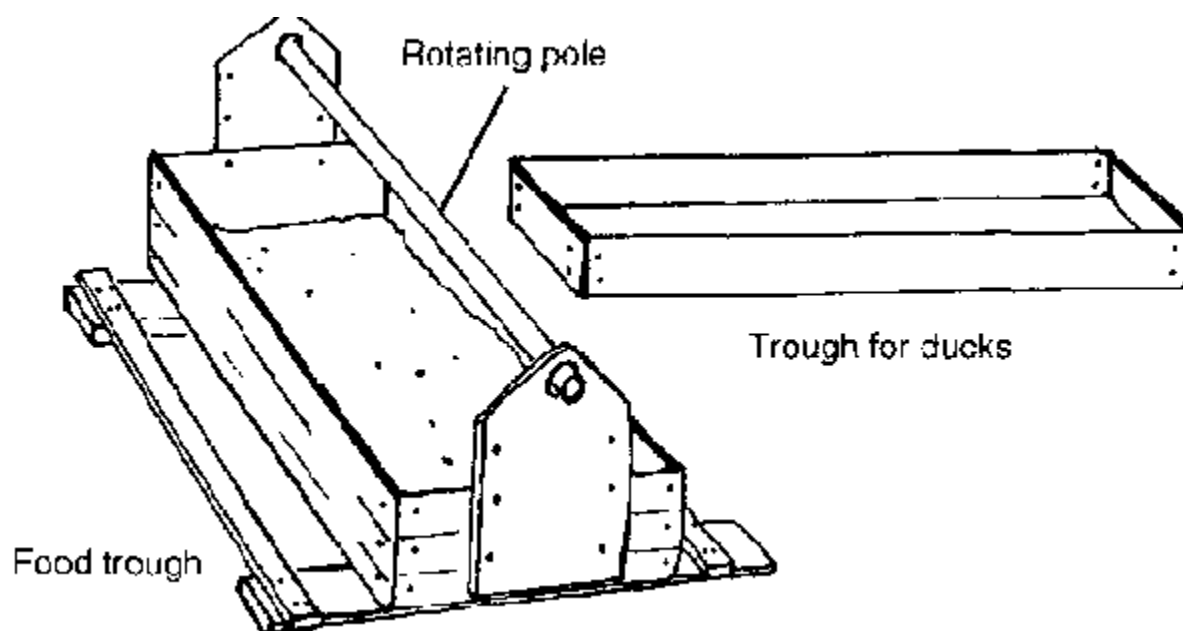

FIGURE 78: FEED TROUGHS (CONTAINERS)

BROODING

When the female bird sits on her eggs in a nest to incubate them she is brooding.

Natural incubation or brooding is the simplest way of hatching a small number of eggs. A broody hen (chicken) will incubate her own eggs or those of another hen or a duck.

Broody hens may refuse to leave the eggs to eat or drink. They can suffer from external parasites (e.g. mites, fleas). Care must be taken to feed the hen and treat her for parasites.

Learning objectives

After studying this unit you should know:

1. How to know that the hen is broody.
2. Using the broody hen to incubate chicken and duck eggs.
3. Care of the broody hen.

THE BROODY HEN

New breeds (types) of chickens may not be good brooders. A good test to check the broodiness of the bird is to put some white balls, or a few hardboiled eggs, in its nest for a day or two. If the bird stays in the nest, and will not easily move off, replace the eggs with 10 - 15 fertile eggs which have been checked.

Natural incubation is the simplest way to hatch small numbers of eggs and the broody hen can be used to incubate and hatch her own eggs or those from another bird. A hen can incubate 12 to 15 chicken eggs or can be used to incubate up to 10 duck eggs.

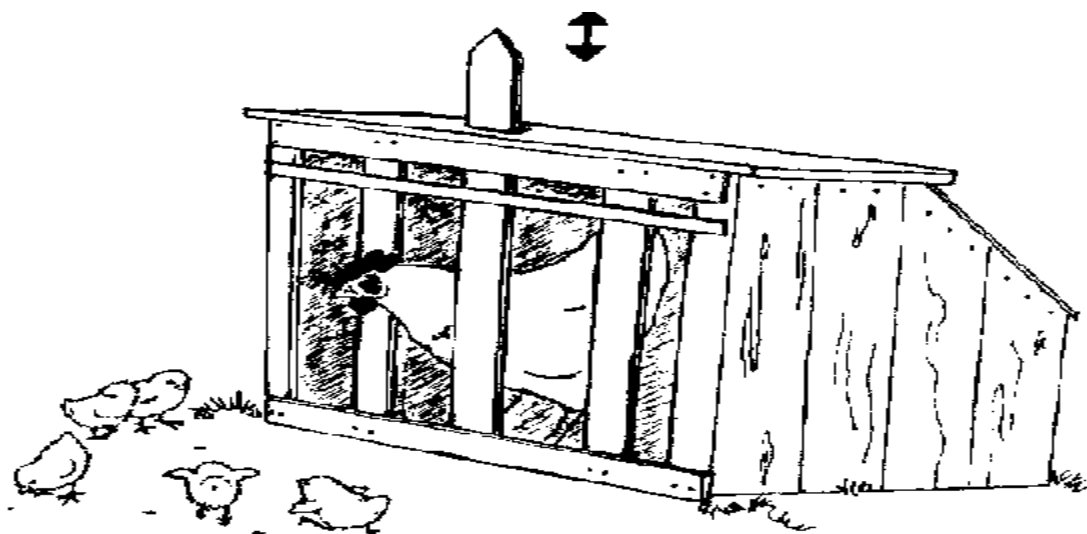

FIGURE 79: THE BROODY HEN

The broody hen is kept in a nesting box. Take her off the nest for 20 minutes each day to give her feed and drink. If a hen is used to incubate duck eggs you will need to sprinkle them with water for the last 14 days of the incubation period.

The eggs of turkeys can also be incubated by a hen. A female turkey will lay up to 15 eggs but a brooding hen can only incubate up to 9 turkey eggs.

CARE OF BROODING HENS

To ensure that the brooding hen does not have any external parasites, she should be treated with a suitable dusting powder before being placed in the nesting box. The nesting material should also be lightly dusted with the powder. This will prevent any parasites being passed on to the chicks. Any holes in the box should be closed to prevent rats getting at the eggs and eating them.

White diarrhea disease kills large numbers of chickens. Do not hatch the eggs of birds which have been infected with this disease. The germ which causes the disease will be in the eggs and will infect the chicks. Ask your veterinary service about this disease in your area.

PRODUCTION

Poultry enterprises may vary from basic backyard poultry keeping to mechanized and automated production plants. Various types of poultry enterprises are illustrated in Table 9.

TABLE 9: TYPES OF POULTRY ENTERPRISES

	Backyard poultry	Farm flock	Commercial poultry farm	Specialized egg production	Integrated egg production
Subdivision of egg production	Pullet growing, feed production	Hatchery production separate from farming	Feed production separate from poultry farms	Chicken meat production becomes independent of egg production	Separate enterprises reintegrated as a business
Main management characteristics	Natural hatching	Artificial hatching and sexing	Feed mixing	Egg processing plant	Controlled-environment houses
Type of farming	Subsistence farming	Mixed farming	Joint egg and meat production	Eggs industry (single commodity)	Egg complex
Labour	Part-time	Part-time	Full-time	Division of management and labour	Separate daily work and random work
Building	Free range	Water feeder	Water feeder	Manure disposal equipment	Egg belt automatically controlled house

Backyard poultry production is at the subsistence level of farming. Birds live free range and hatch their own eggs. Their diet is supplemented with crop waste or food leftovers. The labour involved in backyard poultry production is part-time.

Farm flock production is slightly more specialized. Eggs are hatched at a separate location where the hatch and the sexing of the birds are controlled.

Commercial poultry farm production involves full-time labour and is geared toward producing on a sufficient scale for the sale of both eggs and poultry meat.

Specialized egg production consists of separating poultry for meat and egg production. In the egg producing plant, specialized employees oversee specific aspects of egg production.

Integrated egg production is the most advanced enterprise and involves full mechanization and automation of the egg production cycle including battery egg laying, temperature controls, scientific feeding and mechanized egg collection methods.

TYPES OF BROODERS

Oil barrel - charcoal¹⁷

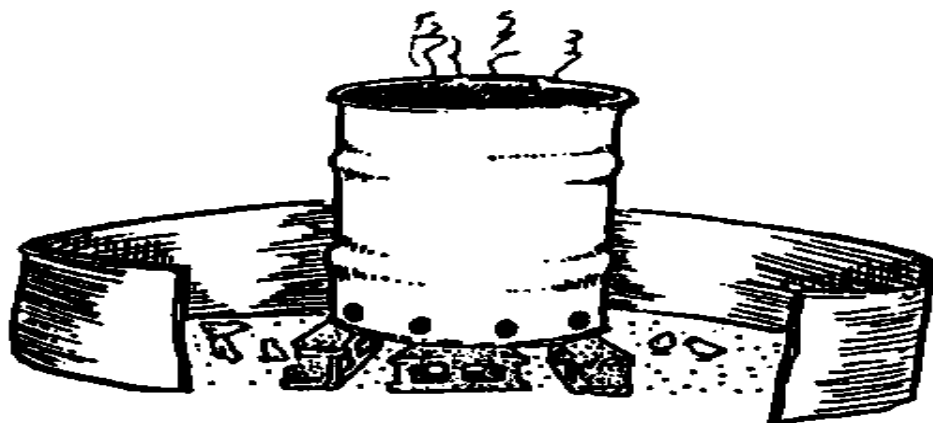

FIGURE 80: OIL BARREL - CHARCOAL

All of the above poultry-keeping methods are used in the developing world, but the majority of the enterprises are backyard poultry and farm flock production. The poultry and egg sectors are highly fragmented. Most of the production is carried out by a large number of farmers, each with a very small flock. The greater part of produce is sold in markets close to the farms.

¹⁷ Source: Reid et al., 1990

Day-old chicks are usually obtained from local hatcheries licensed by international hybrid breeding companies. Farmers or cooperatives of farmers may choose between varieties of chickens for egg production and meat production.

The small chicks can be either naturally or artificially brooded. If artificially brooded, small chicks must be placed in a separate house from laying chickens and it is necessary to protect the chicks from predators, diseases and catching colds. This stage of brooding lasts for eight weeks. In the first four weeks of life, small chicks need to be housed in a brooding box. Some typical types of brooders are shown below and on the previous page.

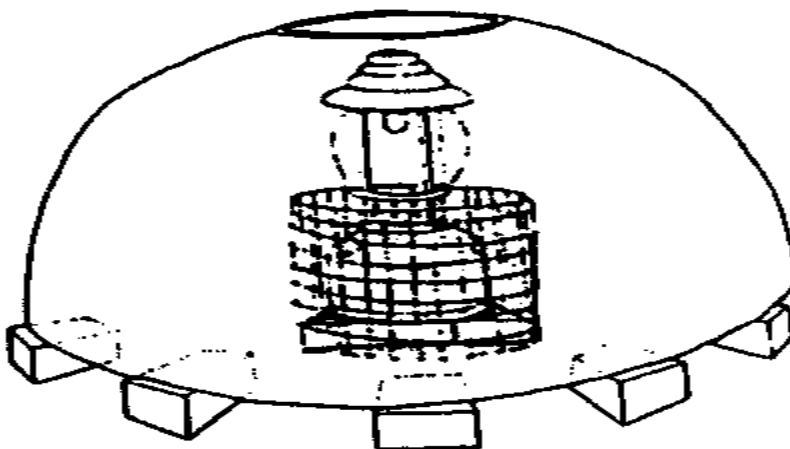

FIGURE 81: KEROSENE BROODER

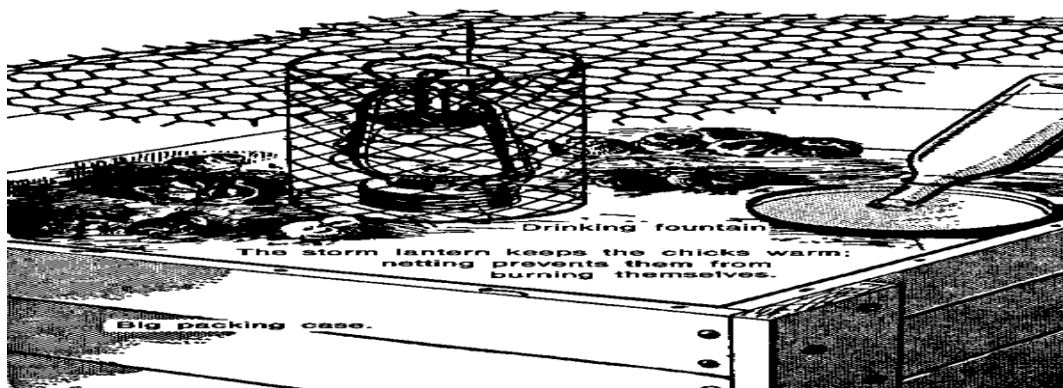

FIGURE 82: STORM LANTERN BROODER

After the first month, small chicks are removed from the brooder box and placed in the brooder house. At two months of age, the chicks enter the grower stage which lasts until they are five months (20 weeks) old. Growers may either be housed separately from small chicks or continue to be reared in brooder-cum-grower

houses. It is important to properly manage the growers as their reproductive organs develop during this period and this will affect their egg production capacity in the future.

When the growers reach 18 weeks of age they are moved to laying houses and begin to lay eggs, which are, however, small and unmarketable. It is not until they are 21 weeks old that the growers reach their commercial laying stage. Layers may be placed in intensive, semi-intensive or free-range types of housing.

The choice of housing is determined by climate, type of production desired and the farmer's financial resources. Some examples of laying houses are shown on the next two pages.

Photographs 1 through 5 are other examples of laying houses.

FACTORS AFFECTING EGG PRODUCTION

Typically, a layer's production cycle lasts just over a year (52-56 weeks). During the production cycle many factors influence egg production; therefore, the cycle must be managed effectively and efficiently in order to provide maximum output and profitability. The following factors influence egg production.

Breed. The breed of the laying bird influences egg production. Management and feeding practices, however, are the key determining features for egg production.

Mortality rate. Mortality rate may rise due to disease, predation or high temperature. The mortality rate of small chicks (up to eight weeks of age) is about 4 percent; that of growers (between eight and 20 weeks of age) is about 15 percent; and that of layers (between 20 and 72 weeks of age) is about 12 percent. The average mortality rate of a flock is from 20 to 25 percent per year.

Types of laying houses¹⁸

¹⁸ Kekeocha, 1985; Oluyemi and Roberts, 1979

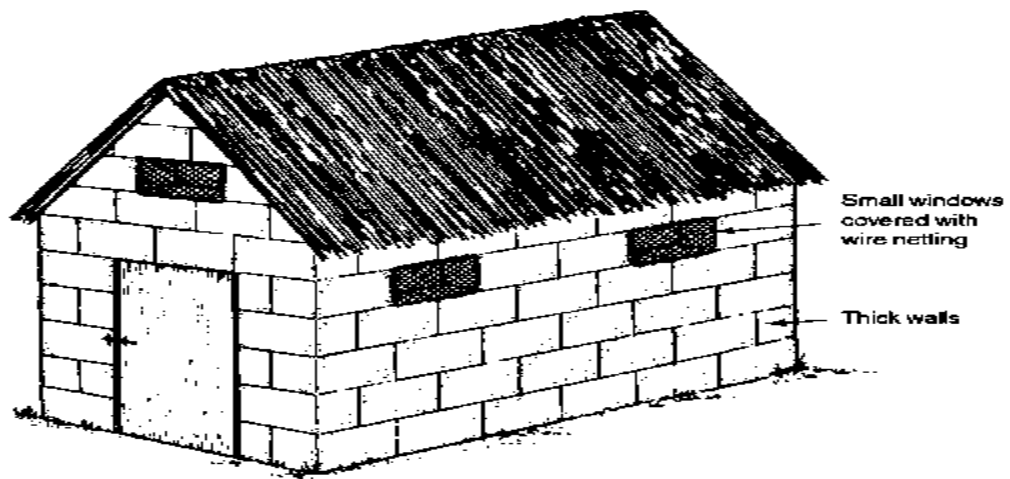

FIGURE 83: HOUSING FOR HOT - ARID CLIMATES

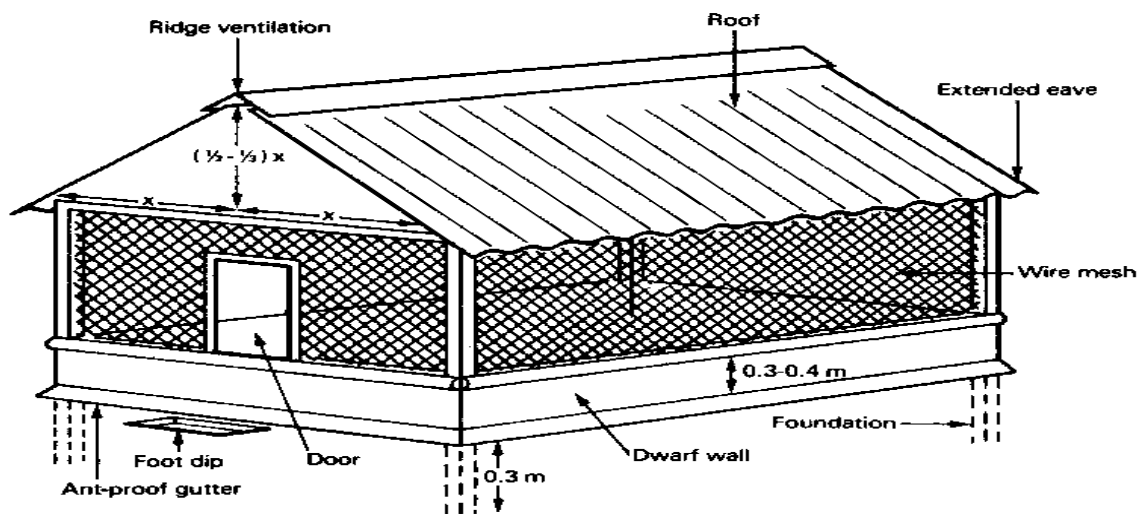

FIGURE 84: OPEN HOUSE TYPE

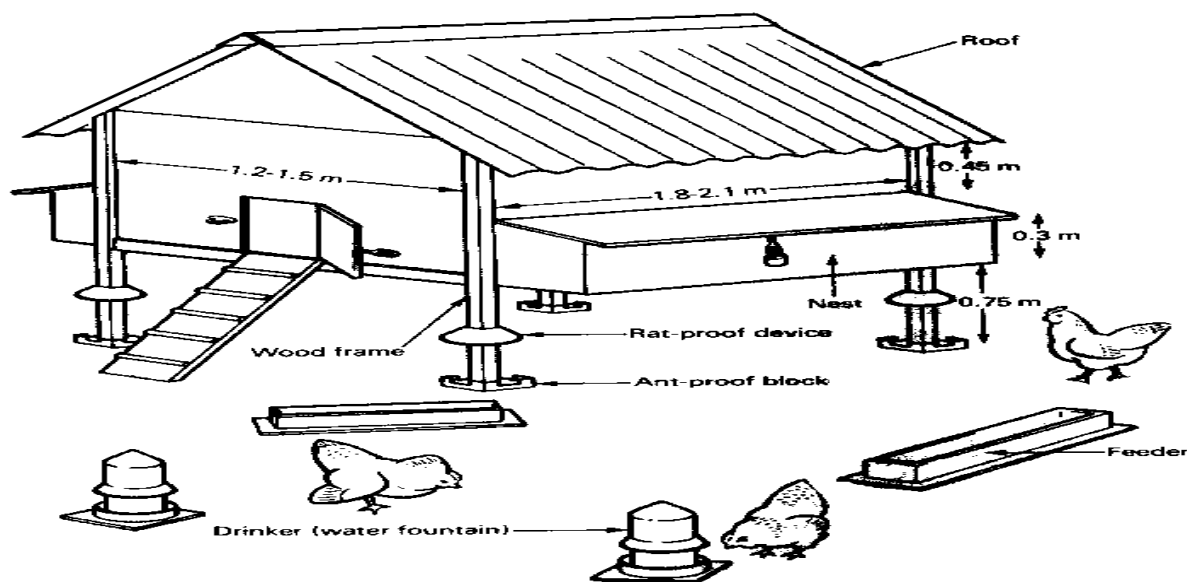
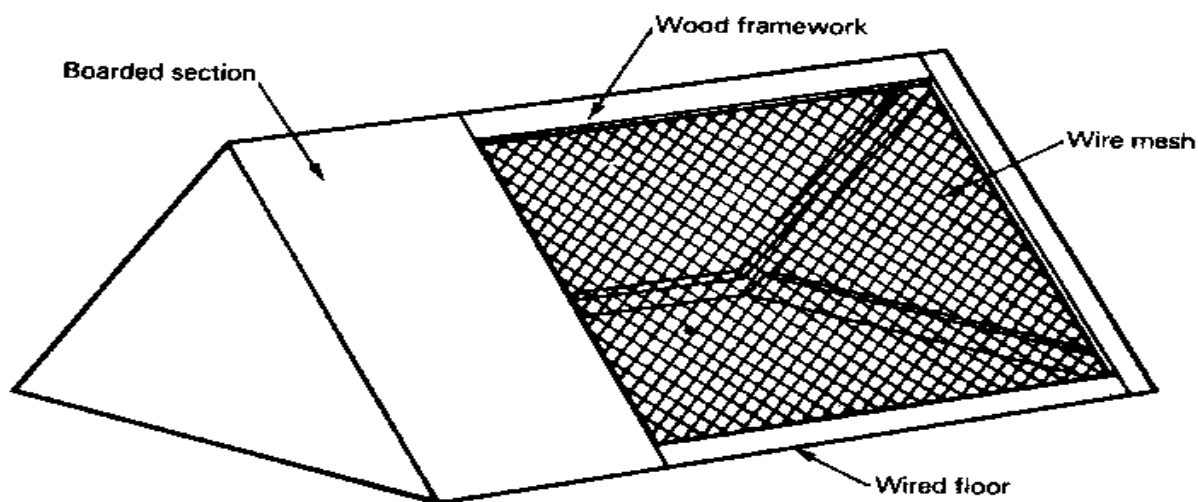

FIGURE 85: MOVEABLE TYPE HOUSING



Age. Birds typically begin producing eggs in their twentieth or twenty-first week and continue for slightly over a year. This is the best laying period and eggs tend to increase in size until the end of the egg production cycle.

Body weight. In general, optimum body weight during the laying period should be around 1.5 kg, although this varies according to breed. Underweight as well as overweight birds lay eggs at a lower rate. Proper management and the correct amount of feed are necessary in order to achieve optimum body weight.

Laying house. The laying house should be built according to local climatic conditions and the farmer's finances. A good house protects laying birds from theft, predation, direct sunlight, rain, excessive wind,

heat and cold, as well as sudden changes in temperature and excessive dust. If the climate is hot and humid, for example, the use of an open house construction will enable ventilation. The inside of the house should be arranged so that it requires minimum labour and time to care for the birds.

Lighting schedule. Egg production is stimulated by daylight; therefore, as the days grow longer production increases. In open houses, found commonly in the tropics, artificial lighting may be used to increase the laying period. When darkness falls artificial lighting can be introduced for two to three hours, which may increase egg production by 20 to 30 percent.

In closed houses, where layers are not exposed to natural light, the length of the artificial day should be increased either in one step, or in a number of steps until the artificial day reaches 16 to 17 hours, which will ensure constant and maximized egg production. Effective day length should never decrease during the laying period.

Feed. Free-range hens will produce more meat and eggs with supplemental feed, but only if they are improved breeds or crossbreeds. The selection of local hens is done on the basis of resistance and other criteria rather than feed utilisation for production.

Fresh and clean water should always be provided, as a layer can consume up to one-quarter of a litre a day.

Lighting schedule¹⁹

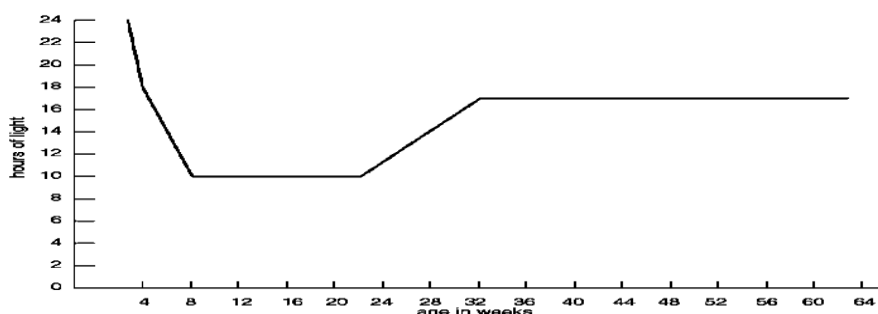

FIGURE 86: LIGHTING SCHEDULE FOR BIRDS

¹⁹ Source: Smith, 1990

Culling. Culling is the removal of undesirable (sick and/or unproductive) birds, from the flock. There are two methods of culling:

- Mass culling, when the entire flock is removed and replaced at the end of the laying cycle; and
- Selective culling, when the farmer removes individual unproductive or sick birds.

Culling enables a high level of egg production to be maintained, prevents feed waste on unproductive birds and may avert the spreading of diseases.

Climate. The optimal laying temperature is between 11° and 26° C. A humidity level above 75 percent will cause a reduction in egg laying.

Temperature and its effects on egg production²⁰

Temperature (°C)	Effects
11 – 26	Good production.
26 – 28	Some reduction in feed intake.
28 – 32	Feed consumption reduced and water intake increased; eggs of reduced size and thin shell.
32 – 35	Slight panting.
25 – 40	Heat prostration sets in, measures to cool the house must be taken.
40 and above	Mortality due to heat stress.

TABLE 10: TEMPERATURE AND ITS EFFECTS ON EGG PRODUCTION

When the temperature rises above 28° C the production and quality of eggs decrease. Seasonal temperature increases can reduce egg production by about 10 percent.

Management factors. Effective and efficient management techniques are necessary to increase the productivity of the birds and consequently increase income. This entails not only proper housing and feeding, but also careful rearing and good treatment of the birds.

²⁰ Source: Kekeocha, 1985

Vaccination and disease control. Diseases and parasites can cause losses in egg production.

Some of the diseases are as follows:

- bacterial: tuberculosis, fowl typhoid
- viral: Newcastle, fowl plague
- fungal: aspergillosis
- protozoan: coccidiosis
- nutritional: rickets, perosis

Some of the parasites are:

- external: lice, mites
- internal: roundworms, tapeworms

Vaccinations are administered to birds by injection, water intake, eye drops and spraying. Clean and hygienic living quarters and surroundings may eliminate up to 90 percent of all disease occurrences.

INTERNAL PARASITES OF CHICKENS AND DUCKS

The gut of chickens and ducks can be infected with a number of different roundworms. Heavy infections cause weight loss, diarrhea and poor egg production.

The thin, red gizzard worm lives in the wall of the gizzard of ducks and is the cause of loss of appetite, weight loss, diarrhea and death of birds.

Both chickens and ducks can be infected with very small parasites called coccidia which live in the wall of the gut. These cause diarrhea, weight loss and can result in the deaths of very many young birds.

Learning objectives

After studying this unit you should know:

1. The problems caused by worm infections of chickens and ducks.
2. The problems caused by coccidia in chickens and ducks.
3. How to treat infected birds.
4. Ways of preventing parasitic infections of birds.

PARASITIC WORMS OF CHICKENS AND DUCKS

Chickens and ducks become infected with worms from soil, feed or water contaminated with worm eggs. Worm eggs survive in warm, damp conditions.

A large white roundworm (10 cm long) is found in the intestine. Small, fine hairworms live in the gut walls. Other worms, about 1 cm long, can be found in the lower region of the gut.

- Worm infections are of greatest importance in young birds and cause poor appetite, loss of weight and diarrhea. Heavy infections can cause death. In older birds loss of weight and poor egg production occurs.
- The gizzard worm causes loss of appetite, weight loss, and diarrhea and may result in the death of ducks, especially young birds.

COCCIDIA IN CHICKENS AND DUCKS

Coccidia cannot be seen without a microscope. Many different coccidia infect different parts of the gut in both chickens and ducks. Birds are normally infected with a number of different coccidia.

Birds are infected by contaminated soil, feed or water and will suffer few problems if the infection is low. Young birds, especially under a month old, can be badly affected. Diarrhea occurs and the droppings may be bloody. Coccidia can kill young birds within 2 weeks of the disease appearing.

Coccidia are the cause of a dangerous disease of young chicks. Ask your veterinarian for advice on this disease. It may kill all the young birds in your community.



FIGURE 87: COCCIDIA IN CHICKENS AND DUCKS

TREATING PARASITIC INFECTIONS OF BIRDS

Worms can be killed by treating the bird with a suitable anthelmintic. Ail worms are killed by tetramisole or levamisole. Birds are either treated separately or the drugs are mixed with the feed or water. Coccidia are treated with several drugs which are added to the drinking water or feed.

PREVENTING PARASITIC INFECTIONS IN CHICKENS AND DUCKS

Infection with all internal parasites in both chickens and ducks can be controlled by keeping birds in clean conditions and stopping them wandering around free.

- Cages and houses should be kept clean with droppings removed every week.
- Feed and water containers should be cleaned out every day.
- Do not allow wet muddy areas to develop around water containers or anywhere else.
- Cages and houses should be thoroughly cleaned before new birds are placed in them.
- Do not keep birds on the same area of ground year after year as contamination of the soil will increase.
- Young birds should be kept separate from older birds.
- Do not place young birds, especially under 3 months old, in runs where older birds have recently been kept as they may develop infection with coccidia.
- If possible regularly treat young birds for coccidia (ask your veterinarian for advice).

When you buy new birds ask your veterinarian or agricultural officers who is selling good birds which will not bring disease into your community's birds.

EXTERNAL PARASITES OF CHICKENS AND DUCKS

A number of lice and mites infect birds and cause severe irritation which leads to loss of feathers, loss of weight and low numbers of eggs.

Small ticks feed on the blood of birds and can carry germs which will cause other diseases.

External parasites will hide in the walls, floors and bedding of the cages and houses where birds are kept. In order to control the parasites, it is necessary to keep these places clean and kill any parasites there.

Learning objectives

After studying this unit you should know:

1. The mites, fleas and lice which infect chickens and ducks.
2. Problems caused by flea, lice and mite infections.
3. Tick infections of chickens and ducks and the problems they cause.
4. How to treat infected birds.
5. How to keep houses and cages clean and free of parasites.

FLEAS, MITES AND LICE INFECTING CHICKENS AND DUCKS

Fleas:

Fleas are small and dark in color and can jump high into the air. They feed on blood and can live without food for a long time. The eggs and young of fleas are found in the birds' nests and cracks in walls and floors of buildings.

One type of flea is found on the wattles and comb of chickens and does not jump away. Its bite causes ulcers to form and large numbers can kill young birds. It also infects ducks and is found around the eyes. They can bite people.

Mites:

A number of different mites infect birds and cause irritation and loss of feathers. The scaly leg mite can cause lameness. Red mites can kill birds and will also bite people.

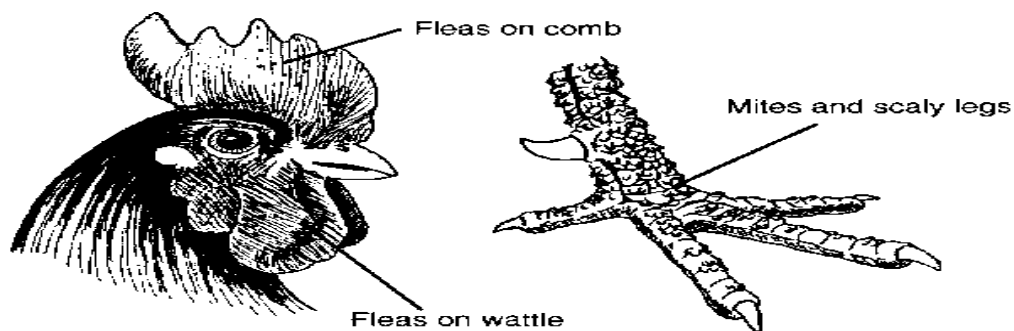

FIGURE 88: FLEAS, MITES AND LICE INFECTING CHICKENS AND DUCKS

Lice:

Chickens can be infected with a number of lice which suck blood and chew the skin. Ducks can also suffer from infections with lice. The parasites can attack all areas of the body and are found on the skin and feathers.

Lice infections cause irritation and prevent birds from resting, sleeping and eating properly. The birds lose weight and egg production drops. Loss of feathers can occur in chickens.

In ducks infection with lice can damage feathers so that the birds die from cold.

Ticks infections of chickens and ducks

Both chickens and ducks can be attacked by the small, blue or brownish fowl tick. They live in cracks in walls or trees and can live for several years without feeding on the blood of a bird. The tick feeds at night and can cause egg laying to stop. It causes tick paralysis in ducks and spreads other infections.

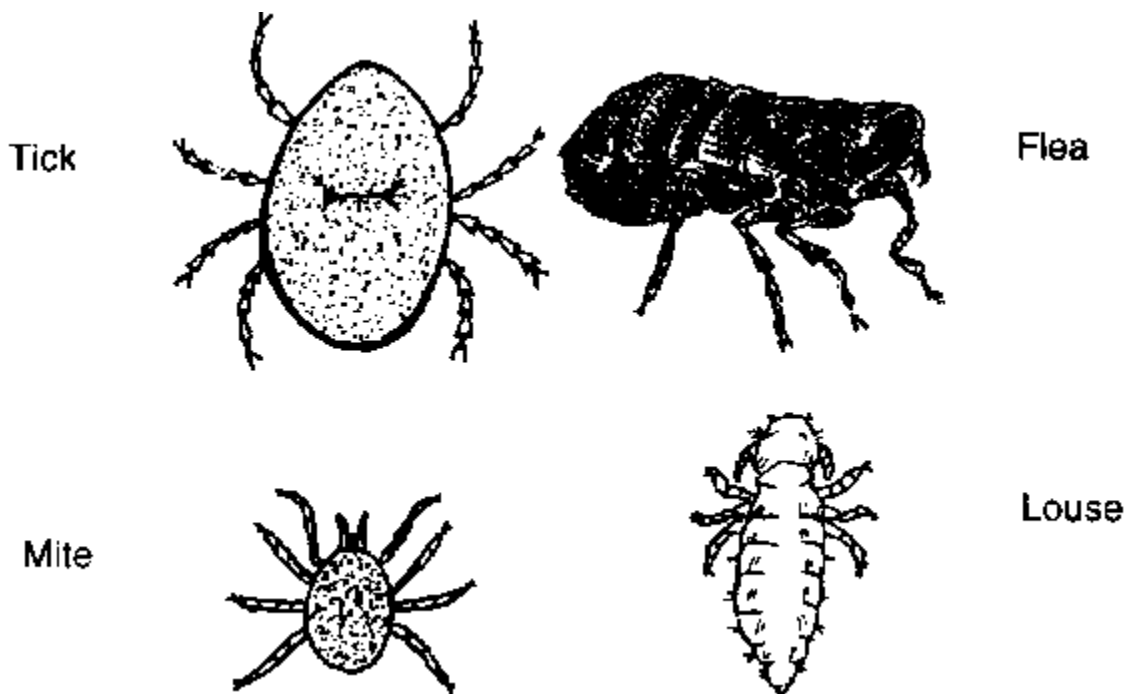

FIGURE 89: THE INFECTIONS OF CHICKENS AND DUCKS

HOW TO TREAT INFECTED BIRDS

To control external parasites birds must be treated with a powder or spray containing, e.g. trichlorphon or malathion. The cages and houses must be thoroughly cleaned.

Chickens will clean their feathers daily with soil or sand (a dust bath). A shallow box containing sand and ashes (left from a fire) will be used by birds and helps to keep the feathers clean and free of infections. A light dusting of a dusting powder will make the dust bath better.

HOW TO TREAT INFECTED BIRDS

Scaly leg of chickens can be treated by dipping the leg in paraffin (kerosene) and then gently brushing the leg. Paraffin must not be allowed to touch the skin or feathers.

CLEANING CAGES AND HOUSES

If birds are infected with external parasites it will be necessary to thoroughly clean out cages and houses. All bedding and dirt must be removed and all parts of the equipment should be thoroughly scrubbed with soap and hot water. If possible you should then spray or paint the equipment with a mixture of paraffin and creosote in equal amounts or with nicotine sulphate (40%). Your veterinary service will advise you on what is available locally for you to use.

You can use a hand pump to spray houses. You can spray with a treatment for external parasites and your veterinary officer can advise you on this.

Remember:

Some of the external parasites of chickens and ducks can bite humans and cause irritation and skin rashes, especially in children.

Infected birds must be treated and the places where they are kept should be thoroughly cleaned and sprayed to kill any parasites there.

Ask your veterinarian for advice as external parasites can be a great problem in keeping birds

39. FIRST AID IN ANIMALS

First aid is the immediate treatment of injured animals or those suffering from sudden illness. The aims of first aid are to preserve life, to reduce pain and suffering and to prevent the deteriorating situation to promote recovery.

PRECAUTIONS to be taken before first aid:

- Before administering first aid, assess the situation for danger to yourself or others.
- Injured animals are usually in pain and may bite. Make sure that the animal is correctly restrained before handling or lifting. One should not put oneself or others at risk while giving first aid.

LIMITATIONS OF FIRST AID:

Under the Veterinary Surgeons' Act 1966, no-one is allowed to practice veterinary surgery unless they are registered in the VCI or State Veterinary Council.

What is classed as Veterinary Surgery?

Veterinary surgery includes the followings:

- The diagnosis of diseases and injuries including diagnostic tests
- Giving advice based on such diagnosis
- The medical and surgical treatment of animals.
- Surgical operations

Classification of Emergency for providing first aid:

An emergency can be classified as one of three types:

- **Life-threatening emergencies.** These require immediate action by the owner or first aider at home, and the vet and nurse at the surgery.
- Emergencies requiring **prompt attention** at the surgery but where life is not immediately threatened.
- **Minor** - where telephone advice and first aid enables the owner to keep the animal comfortable until an appointment with a veterinary surgeon

Examples of different types of Emergency:

LIFE-THREATENING:

- Unconsciousness
- Conscious collapse with dyspnoea or cyanosis

- Severe haemorrhage
- Severe burns
- Poisoning
- Snake bites

Prompt Attention is needed in following conditions:

- Conscious collapse
- Dyspnoea,
- Fractures / dislocations
- Haemorrhage
- Gaping wounds
- Severe dysuria
- Dystocia

Minor conditions are as follows:

- Insect stings
- Minor wounds (where the haemorrhage is easily controlled by bandaging)
- Minor burns
- Abscesses
- Slight lameness
- Haematuria

Examination of an Injured Animal is made in first for the followings:

The initial checks that must be made for:

- AIRWAY
- BREATHING
- CIRCULATION

ABC of First Aid:

AIRWAY: The followings may be performed:

- Check that the airway is clear
- Pull the tongue forward
- Remove any collar or harness

BREATHING

- Look and listen
- If the animal is not breathing, proceed with artificial respiration

CIRCULATION

- Check the heartbeat/pulse
- Apply regular, intermittent gentle pressure to the chest if you are sure there is no heartbeat

ABC OF FIRST AID

- As soon as the airway, breathing and circulation have been assessed and any necessary action taken:
- Control any severe haemorrhage. Pressure can be applied using a bandage, a towel, or even your hand
- Check the animal's level of consciousness
- Treat for shock by keeping the animal warm. This is best done by covering the animal in a blanket to conserve body heat.

Examination of an injured animal

Any examination should be done methodically in order to ensure that no areas are missed. Examinations usually start at the head. All areas of the body should be checked for any abnormal swelling, haemorrhage, discharge, deformity, fracture, wound or sign of pain should be noted.

Examination of an injured animal

- **Nose** - Haemorrhage (epistaxis) and whether is present from one or both nostrils
- **Mouth**
 - Color of mucous membranes
 - should be pink
 - Fractured teeth
 - Ulcerated tongue or strange odours which could indicate poisoning
- **Eyes**
 - Color of conjunctival membranes (pink – normal; yellow – jaundice; blue – cyanosis; pale – shock or blood loss; red – toxins, heatstroke)
 - Any injuries to eyeball or eyelids
 - Size of pupils
- **Ears** – Haemorrhage
- **Skull** - Fractures
- **Limbs** - Fractures, deformities, wounds, paralysis, loss of function.
- **Rib cage** - Fractured ribs or wounds penetrating chest.

- **Abdomen** - Bruising or swelling (could indicate internal bleeding).

Spine - Deformities indicating fractures or dislocation

- **Pelvis** - Fractures, deformities.
- **Perineal region** - Haemorrhage from prepuce, vulva or anus which may indicate internal bleeding.
- **Tail** - Voluntary movement.
- **General body surface** - Matting of the fur which could indicate an underlying wound.

RECOVERY POSITION

Put any injured animals into the recovery position and contact the veterinarian for advice.

- **Lay animal on its right side.** This allows access to the left side so that the heartbeat can be palpated and cardiac massage to be performed if necessary.
- **Straighten the head and neck.** This opens the airways.
- **Pull the tongue forward and to one side of the mouth.** This again opens the airways and also allows any secretions (vomit, saliva etc) to drain away
- **Remove the collar or harness.** This again ensures that the airways aren't restricted
- **Check the heart and pulse rate.** This lets you know if the animal is alive and also whether there are any problems with the circulation.
- **Check the breathing rate.** This lets you know whether the animal is breathing or not, and therefore whether artificial respiration is necessary. Slow or fast breathing rates can also indicate different conditions e.g. fast breathing rate could be due to heat stroke
- **Check for signs of bleeding.** This lets you know if there are any serious wounds that need dressings immediately. Bleeding also tells you the animal is alive!
- **Check body temperature.** Low temperatures could be due to shock or hypothermia and high temperatures could indicate heat stroke.
- **Check the state of the limbs.** Look for fractures or wounds.
- **Check the level of consciousness.** This is done by checking reflexes. Knowing whether an animal is conscious or unconscious is important and will need to be reported to the vet.
- **Check the color of the membranes.** Normal mms are pink. Pale mms can indicate shock or blood loss, blue (cyanotic) mms indicate a problem with getting oxygen, and very red mms can indicate infection

- **Check for signs of unusual odour.** Unusual smells can indicate the cause of the collapse – e.g. the smell of pear drops can be a sign of diabetes. A sweet smell could be antifreeze – a poison which is attractive to dogs

RULES OF FIRST AID

- Don't panic
- Maintain the airway
- Control haemorrhage
- Contact the veterinary surgeon as soon as possible

First Aid Kit

Which items should a first aid kit contain?

- **Bandages**
 - Roll of adhesive bandage (e.g. elastoplast) OR cohesive bandage (sticks to itself but not to fur e.g. Vet Wrap)
 - 2 x rolls of white open-weave/conforming
- Tweezers to remove thorns etc
- Sterile eye wash bottle
- Roll of cotton wool
- Sterile wound dressings
- Dog muzzle (or length of non-stretch bandage)
- Swabs
- Nail clippers to cut overlong or broken nails
- Antiseptic wash e.g. Hibiscrub
- Round-ended scissors
- Salt – to clean wounds mix 1 teaspoon of salt to 1 pint of water
- Cotton wool
- Thermometer & lubricant

Sticky tape

- Address and telephone number of veterinary practice
- Leaflet containing basic first aid advice – to use as a reference
- Dog lead

- Buster collar

For larger animals it is also useful to have:

- Access to a rug or blanket that can be used as a stretcher

EMERGENCY PROCEDURE

When you come across an accident or an animal in severe distress, immediately proceed with the basic emergency drill, as given below:

- If breathing appears to have stopped completely, check for a heartbeat.
- Normal heartbeat can be felt by placing the fingertips on the lower part of the chest wall on the left side, just behind the front leg.
- Airway - Ensure that there is nothing blocking the animal's nasal passage. Squeeze the nasal passage with a flat palm. Blow into the nose; it helps clean the nasal passage.
- Bleeding - To control bleeding, tightly press a cold compress or cloth against the wound. Repeat and bandage. If blood is bright red and pumping, it is from an artery. Apply a tourniquet above the wound. If the blood is dark red and flowing regularly, apply the tourniquet below the wound.
- Collapse, Convulsions and Lack of Consciousness – Ensure the animal in place where it will not receive any further injury. Start artificial respiration. Convulsions occur in cases of heat stroke, severe exhaustion and poisoning. Do not restrain an animal when it is having a spasm. Administer glucose and a warm drink orally, once the animal recovers from the fit. Give Diazepam (to calm down the animal) orally after consulting a veterinarian.

COMMON PROBLEMS AND HOW TO ADMINISTER FIRST AID:

Blood in Vomit - Don't feed the animal, take it to the vet. The bleeding could be due to:

- A foreign body like a sharp edged nail, glass etc.
- Internal injuries.
- Nasal bleeding.

Burns - Wash with plenty of cold water. Give a painkiller tablet. Cover the burnt area with a clean soft cloth, either dry or soaked in tea decoction. Keep the animal clean and warm to avoid shock. The animal must be given either plain water or water diluted with glucose. Call the vet.

First aid and Treatment of Burns:

- Depending on the type and extent of the burn, it can often be treated at home.

- Electrical burns can cause shock and must be treated immediately by a veterinarian.
- If shock occurs, keep the animal warm with heating pads or hot water bottles and a blanket or heavy coat.
- Thermal burns can be treated topically by applying aloe or vitamin E oil.
- Friction burns can be treated topical ointment.
- If foreign matter is embedded the animal should be taken to a veterinarian.
- Chemical burns: Flush immediately with large quantities of cold water

Choking - If something is stuck in the throat, try to get it out with your fingers or a long spoon. Hold the tongue down with a hanky if necessary. If the animal loses consciousness, clear the throat by massaging it downwards. Open the mouth and examine for any foreign body which is causing choking. If visible and not sharp, then slowly pull out with forceps and give artificial respiration. Never give your dog or cat small chicken or fish bones. These are the most common causes of choking in pet animals.

Heat Stroke - Increase in body temperature beyond the point of normal physiological temperature is called a heat stroke. It is due to hot weather, high humidity, inadequate ventilation, exposure to direct sunlight and overcrowding. The symptoms of a heat stroke are:

- High rise in temperature.
- Oral mucosa inside mouth and tongue.
- Inner lips turn bright red in color.
- Red eyes.
- Weakness.
- Convulsions.
- Panting, Heavy breathing.
- High pulse rate.
- Collapse/shock.

First Aid:

- Place animal in a cool, well ventilated place or a shaded area.
- Give small amounts of cold water containing glucose or sugar frequently.
- Ice packs should be applied on the head, forehead and all over the body. If you cant get ice, apply water all over the body and cold towel compresses on the head and chest
- Once first aid has been administered, and the animal is stable, consult a vet.

FIRST AID KIT:

Nobody can fully plan for an emergency, but it always helps to be equipped with the basics. Keep a first aid kit in your house and car for when you come across a sick or injured animal. The first-aid kit should contain:

1. Gauze Bandages
2. Cotton Wool, Cotton Rope
3. Adhesive Tape
4. Dettol, Savlon
5. Scissors
6. Antiseptic, Antibiotic Ointment
7. Betadine Lotion
8. Disposable Gloves
9. Clean piece of white cloth
10. Tabs of Paracetamol/Crocin, Avil, Perinorm, Brufen, Analgin/Novalgin
11. Tissue Paper
12. Thermometer
13. Tincture of Benzene
14. Tincture of Iodine
15. Useful extras – Torch, Blanket, Old Rugs, Paper, Pencil Chains and Tape Muzzle

SUGGESTED CONTENTS FOR FIRST AID BOX:

- **Sterile Saline Wash.** Sterile saline wash is useful if the animal has debris or smoke in their eyes. Apply liberally and try to flush the eyes until all debris is removed. You can also use sterile saline to flush out minor wounds.
- **Water.** Water can also be used to flush out minor wounds. It is useful for rehydrating a pet, soothing burns, washing off toxins, soaking a paw, or cooling an overheated pet.
- **Bandages.** Gauze, clean rags, even a sock can be used as bandage material to help control bleeding and keep wounds clean until they can be treated by the veterinary surgeon. Sanitary pads can be used to cover wounds before applying a bandage. Non-adhesive vet wrap is also great to have in a pet first aid kit, as it does not stick to animal fur and is easier to remove.
- **Tape.** Micropore tape is useful for securing dressings (and is easy to tear). Alternatively, duct tape can be useful for holding temporary bandages in place.
- **Blanket/towel.** A blanket or towel can be used to help keep your pet warm and combat shock.

- **Gloves.** If you can wear gloves when dealing with an injury it helps to reduce any further contamination of the injury. Discard after use.
 - **Plastic pouches/bags.** Used to cover foot injuries and help keep them clean, fasten with tape. This will help minimise blood spillages on to carpets, furniture and your car.
 - **Scissors.** For cutting tape, gauze, splints, or fur.
 - **Tweezers.** Tweezers can be useful for removing objects like thorns from a paw. Tweezers are more likely to remove the entire object, where as fingers can break an object and leave part remaining.
 - **Washing up liquid.** Washing up liquid, is very effective in removing toxins from the skin and fur. Just remember to rinse thoroughly with water afterwards.
 - **Contact details.** It is worth making a note of phone numbers for your local vet and the emergency service.
1. List of medicines and indications for each drug

DIARRHEA AND CONSTIPATION

When an animal passes watery droppings many times a day it has diarrhea.

Animals with diarrhea lose water and salt from their bodies. They become weak, thin and can die. It is common in young animals and kills many.

Constipation occurs when the animal cannot defecate or it passes droppings with difficulty.

Learning objectives

After studying this unit you should know:

1. How to recognize diarrhea and constipation.
2. What causes diarrhea and constipation.
3. Diarrhea in different animals.
4. Treatment and control of diarrhea.
5. Treatment of constipation.

RECOGNIZING DIARRHEA

Diarrhea is a condition in which animals pass watery droppings (faeces) many times a day. The droppings are loose, runny and smelly and are a different color from normal. Droppings can become dark green, dark brown or reddish black in color because of blood in it. In some cases, e.g. rinderpest, the animal has diarrhea which has a very bad smell.

Causes of diarrhea

Diarrhea may continue for one or two days and then stop. This type of diarrhea is caused by:

- The wrong feed was given to the animal.
- A sudden change in the animal's feed.
- Feeding silage can sometimes cause diarrhea.
- Feed was old, rotting or fermenting.
- Diarrhea can be caused by germs (a high body temperature may occur).
- Infection with parasites can cause diarrhea which sometimes contains blood.

DIARRHEA IN RUMINANTS

Diarrhea in cattle, sheep, goats and buffaloes can be caused by:

- Germs and internal parasites, especially in young animals on pasture.
- Germs infecting the intestines of young animals (body temperature not usually elevated).
- Overfeeding calves with poor quality powdered milk

If cattle have diarrhea and also have mouth lesions (not normal) you must ask your veterinarian for advice.

Diarrhea in sheep and goats can result from:

- Infection with a germ (body temperature may be elevated).
- Internal parasites in young animals on pasture.
- *Young animals can show diarrhea after weaning.*
- Diarrhea in the pig can be caused by infection with germs (body temperature may be elevated) and internal parasites.

DIARRHEA IN CHICKENS AND DUCKS

- White diarrhea disease of chickens is caused by a germ (bacteria) which passes from the mother to her young. In adult birds it causes greenish-brown diarrhea but in the young bird the diarrhea is white in color.
- Diarrhea containing blood can be caused by the small parasites called coccidia which infect the gut.

Treatment

Diarrhea accompanied by fever is caused by germs. If the diarrhea continues for more than two days and the body temperature has gone up, you should ask your veterinarian for help. The animal may be treated with antibiotics or by sulpha drugs.

Diarrhea will cause the animal to lose water and salts and if this is allowed to continue the animal can die. If you cannot get veterinary help you can give the animal a home treatment of rehydration fluid. To make rehydration fluid mix six teaspoons of sugar and half a teaspoon of salt with 1 litre of clean, warm water. Give this as a drench (500 ml for sheep or goats) four times a day for 3 days. Larger animals require more fluid, 5% of body weight 2 times per day.

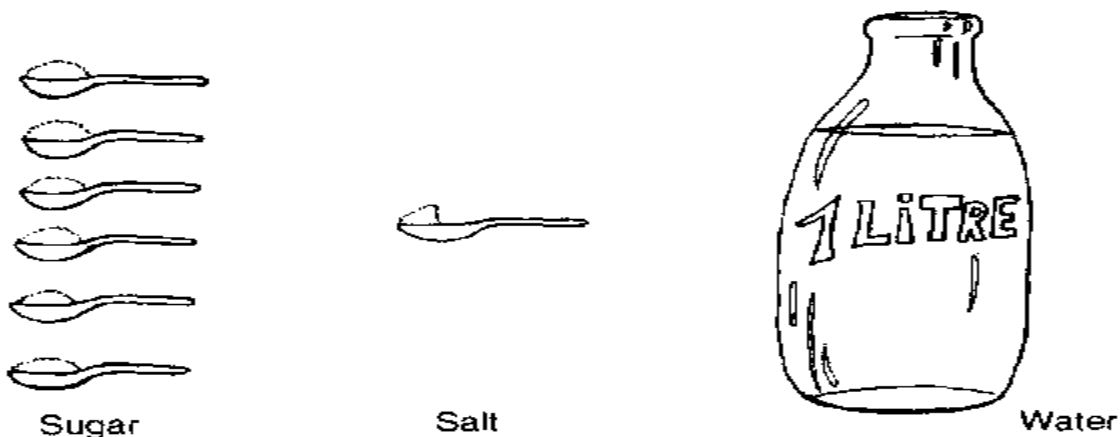

Constipation

Constipated animals cannot defecate or they pass very hard droppings with difficulty. The animal with constipation is easy to spot.

Constipation is treated by giving an enema. Warm soapy water is injected into the rectum. Epsom salts or commercially produced oils can be given by mouth to relieve constipation.

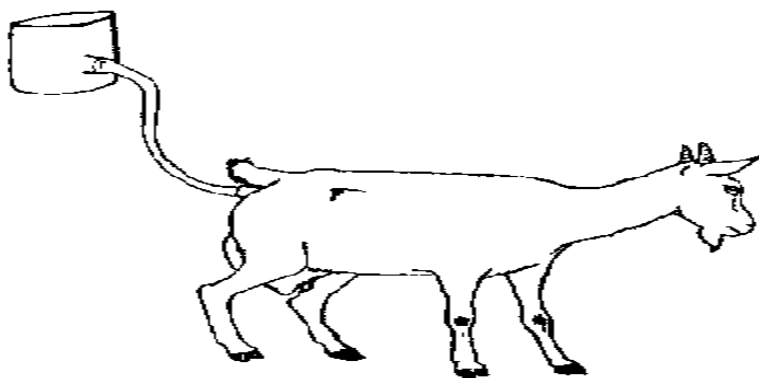

SALIVATION AND MOUTH PROBLEMS

Saliva is produced by glands in the mouth and helps in the chewing and swallowing of food.

Excessive salivation, when saliva shows as dripping, threads or froth around the mouth, is not normal.

Excessive salivation accompanied by mouth lesions and fever is a sign of disease.

Learning objectives

After studying this unit you should know:

1. Recognize excessive salivation.
2. Recognize choking (feed stuck in the gullet).
3. Know the types of mouth lesions.
4. Blisters in the mouth.
5. Treatment of mouth problems.

EXCESSIVE SALIVATION

Excessive salivation accompanied by chewing movements may be caused by a number of different things.

Open the animal's mouth and check what is causing the problem. It may be due to:

- Foreign bodies (thorns, nails, pieces of feed) in the mouth or between the teeth
- Teeth problems and abscesses
- Poisoning
- Pieces of feed stuck in the oesophagus (gullet) causing choking

CHOKE (FEED IN THE GULLET)

This happens when large or dry pieces of feed become stuck in the gullet (oesophagus). It is common in cattle and can occur in horses. The obstruction must be removed.

Choke in ruminants causes bloat (tympany). The best way to remove the obstruction is to push upward toward the mouth from the outside on the left side of the neck.

Another way is to press hard on the top of the mouth with your fingers to make the animal open its mouth. Then pour a small amount (10 - 20 ml) of oil into the mouth of the animal or pass a stomach tube down the gullet.

SALIVATION ACCOMPANIED BY MOUTH LESIONS

Sometimes an animal produces excessive saliva which drips or froths from the mouth. This is because of a lesion in the mouth or on the tongue or lips. Mouth lesions can be:

- Red spots and blisters (watery fluid filled bags of skin) in the mouth
- The skin comes off from some areas leaving red tissue showing
- The tongue is swollen

Excessive salivation, mouth lesions and fever are signs of infectious disease and you should get your veterinary officer to look at the animal immediately.

Rinderpest and foot and mouth disease cause excess salivation and mouth lesions. Other diseases also cause these signs.

Dress lesions of the mouth with antiseptic. Your veterinarian may recommend antibiotic injections for several days

FEVER

It is important to know the body temperature when checking the health of an animal. Use your thermometer to take the body temperature if you think an animal is sick

If the body temperature is higher than normal the animal has a fever. Fever is one of the commonest signs of an infectious disease.

A small rise in body temperature is called a slight fever and a large rise is called a high fever. When the body temperature is lower than normal the animal has a subnormal temperature, which could be caused by starvation, bleeding or dehydration.

Fever, like diarrhea, causes the animal to lose a lot of water and salts from the body.

Learning objectives

After studying this unit you should know:

1. When an animal has fever.
2. What causes fever.
3. What to do with a fevered animal.

FEVER

You should know the appearance of the healthy animal. If you believe that an animal is not healthy, talk to the owner or keeper to discover all that you can about it. Examine the animal and use your thermometer to take the body temperature.

If the body temperature is higher than normal the animal has a fever. The increase in the temperature tells you how great a fever the animal has.

The normal body temperature of sheep is 39°C. If the temperature is 40°C or 41 °C, then the sheep has a slight fever. If the temperature is from 41.5°C to 42°C, then the animal has a high fever. A temperature of 38°C is subnormal.

For all animals, a rise of 1°C or 2 °C in body temperature is a slight fever while any temperature more than 2°C above normal is a high fever.

THE CAUSE OF FEVER

Fever, especially high fever, is the result of an infectious disease caused by germs. When some types of germs get inside the body of a healthy animal, it will become sick. Animals can get germs from:

- Breathing in germs from the air.
- Dirty water and bad feed.
- Dirty animal housing from which droppings and urine have not been cleaned.
- Milk, saliva, urine or blood from sick animals.
- Fly bites and injuries.

Treatment of fever

If an animal has a fever, separate it from the others and keep it in a shady, cool place with plenty of clean, fresh water. If the animal has a slight fever and shows no diarrhea, constipation, discharge from the eye or mouth or any other signs of ill health, it should be given some good feed. Keep a check on it for a day or two to see if the fever drops.

If the animal has a high fever and diarrhea, a discharge or other signs of ill health you should give it only clean fresh water and if possible get veterinary help. Watch closely for signs of improvement over the next two days. If the animal does not return to normal (eating, drinking and movement) you will have to contact the veterinarian to discover the problem and to how to treat it.

COUGHING AND BREATHING PROBLEMS

A cough is a strong, forceful expiration (breathing out) through the mouth.

A sneeze is a short, forceful expiration through the nose.

Difficulties in breathing and very fast breathing are other problems of the respiratory system and are not normal conditions.

Breathing problems accompanied by fever and discharge from the nose are very bad signs and mean that the animal has an infection.

Learning objectives

After studying this unit you should know:

1. When an animal has a cough.
2. Sneezing.
3. Discharge from the nose.
4. Treating animals with respiratory problems.

Coughing

A cough is a strong forceful expiration. Coughing is caused by:

- Infectious diseases of the lung or windpipe.
- Parasites in the lung.
- Fluid or mucous in the lung or windpipe.

- A medicine (drench) going into the lungs instead of through the gullet to the stomach.

Pigs can cough as a result of being given dusty (powdery) feed.

Sneezing

A sneeze is a strong, forceful expiration through the nose. It can be caused by an infection of the inside of the nose or from maggots of the nasal fly.

Difficulties in breathing

Infection of the lungs or windpipe will cause the animal to have difficulty in breathing. It will make noises as it breathes.

A blockage of the windpipe caused by a foreign body or an abscess will also cause difficulties in breathing.

Fast (rapid) breathing

Fast breathing is caused by an infectious disease and is associated with a fever. It is easily noticed by looking at the movements of the chest as the animal breathes.

Treatment

If an animal coughs, and there is no discharge from the nose or a sign of fever, you should suspect a foreign body, dust in the windpipe or lungs or lungworms as causes of the problem. Check for any foreign body or if necessary treat for lungworms.

A cough accompanied by a fever and discharge from the nose and eyes is caused by an infection. You should ask your veterinarian for help but if this is not possible you can give the animal antibiotics or a sulpha drug for three or more days.

Sneezing when there is no fever is caused by a foreign body or nasal fly maggot in the nose. If an animal has a foreign body or abscess in the windpipe it will have difficulties in breathing but will not have a fever.

EYE PROBLEMS

Injury or infection of the eye or vitamin deficiencies can cause blindness in animals. Blind animals may not survive because they will be unable to find feed.

A problem in one eye is the result of injury or a foreign body. A problem in both eyes accompanied by fever, means that the animal has an infection or a serious disease. If blind in both eyes but without a fever, you should suspect a vitamin deficiency such as deficiency of vitamin A or B to be the cause.

Learning objectives

After studying this unit you should know:

1. The structure of the animal eye.
2. Causes of eye problems.
3. Treatment of eye problems.

The eye

The eye is important to the survival of the animal. The glass-like surface of the eye is called the cornea. The eye can be covered by the eyelids which protect it.

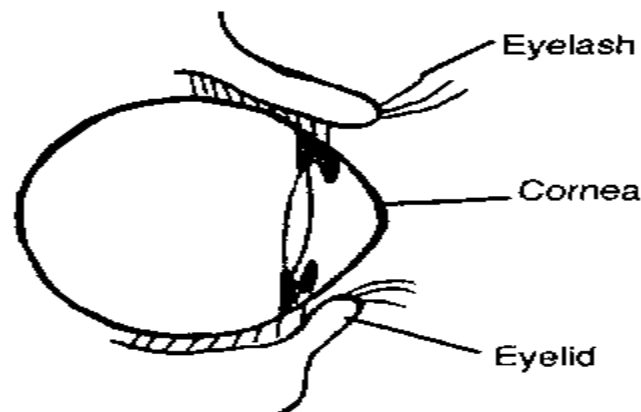

Eye problems

If one eye is red, swollen and watery this may be due to:

- A foreign body such as sand, dust or a seed in the eye.
- An injury or cut to the cornea.
- Eye infection caused by flies or dirt.

If both eyes are swollen, red and watery and perhaps the animal is unable to open its eyes, this is a sign of infection. You should check the body temperature for fever. Many diseases cause eye problems.

Blind animals

It can be easy to spot a blind animal as it will start to walk into objects. A blind animal will be difficult to keep. To check for blindness make a threatening (quick) movement towards the animal's face with your hand without touching the animal or creating a wind which it might feel. If it does not blink, it is usually blind.

Vitamin A, which is present in green feed, silage and good hay is important for good eye sight. If animals are fed only old, dry feed or graze pasture in drought areas they develop night blindness and cannot see at dusk or night.

Treatment

To treat eye problems, you should:

- Ask someone to control the animal for you if it has a foreign body (dirt, sand) in the eye.
- With clean hands, and using the thumb and first finger, open the eyelids and press gently inwards.
- Use a clean, soft cloth to remove the foreign body from the eye.
- Put a drop of oil or ointment in the eye.



If you have difficulty in removing a foreign object:

- Put a drop of olive, castor or cod liver oil in the eye as this can help to remove dirt.
- Put a little sugar in the eye, this will cause tears which will wash out the eye.

Use eye drops or ointment to treat red, swollen eyes

Treatment

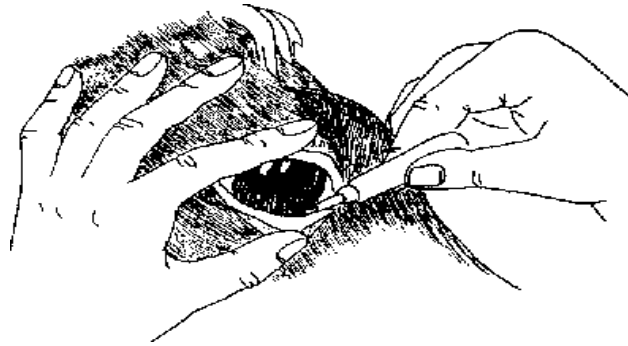

If you cannot open a swollen eye do not force the eyelids open. You must get veterinary help. If both the eyes are swollen, red and watery and the animal has a fever put the animal in a shady place away from others. This is a sign of infectious disease and the animal may need to be treated with antibiotics.

Vitamin A and B1 deficiency are prevented by feeding silage or supplemental feed during the dry season. These vitamins can also be injected to treat these vitamin deficiencies.

WOUNDS AND BLEEDING

A wound is a cut or tear in the skin. All wounds bleed, they are painful and can become infected with germs or maggots.

Sometimes an animal can bleed from wounds inside its body which have been caused by parasites, by an accident, or in the female from problems as she gave birth. This is internal (inside) bleeding.

The blood carries oxygen from the lungs to every part of the body. If the body loses too much blood it will not get enough oxygen and the animal will die.

All wounds should be carefully cleaned and the bleeding stopped.

Learning objectives

After studying this unit you should know:

1. The causes of wounds.
2. First aid for wounds.
3. How to stop bleeding.
4. Internal bleeding.

5. Treatment of old wounds.
6. The navel cord and wounds from castration.

First aid for wounds

Animals can be injured by the horns and bites of other animals, thorns and sharp objects such as glass, wire and nails. These wounds will become infected with germs because of the conditions in which animals live.

If there is not too much bleeding, clean the wound with salt water and remove all dirt from it. Cut away the hair or wool from around the wound. If you have any disinfectant use it to dress the wound. Dusting powder can be used to keep the wound clean.

Bleeding

Bleeding from small or surface wounds can be stopped by pressing down hard on the wound with a clean cloth. If the blood soaks through the cloth put another on top rather than remove the first one. When the bleeding has stopped clean the wound and treat it.

You will need veterinary help to deal with bleeding from large or deep wounds. If you cannot stop the bleeding by pressing down with cloths you can use a tourniquet.

A tourniquet is a piece of rope or cloth which is tied across a blood vessel. It can only be used for wounds in the legs or tail.

You do not use a tourniquet around the neck.

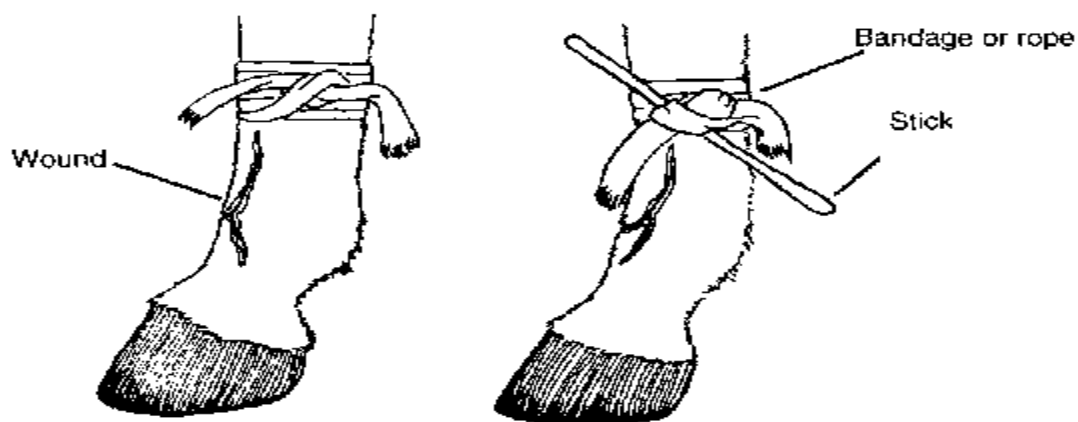

Tie the rope around the limb above the wound. To tighten it put a stick under the rope and twist it tight until the bleeding stops. Do not leave the tourniquet on for more than 20 minutes. Release it slowly and if necessary tighten it again. Clean and treat the wound after the bleeding has stopped.

Bleeding from a broken horn

If the horn of an animal is broken, try to stop the bleeding by putting a pad or clean cloth on it and holding it in place with a bandage. A temporary tourniquet around the base of the horn will stop bleeding.

If this does not stop the bleeding, a red-hot piece of metal can be placed directly on the bleeding spot for half a minute to cauterize the horn and the blood vessel. This may have to be done to several bleeding spots on the horn or to the skin surrounding the horn.

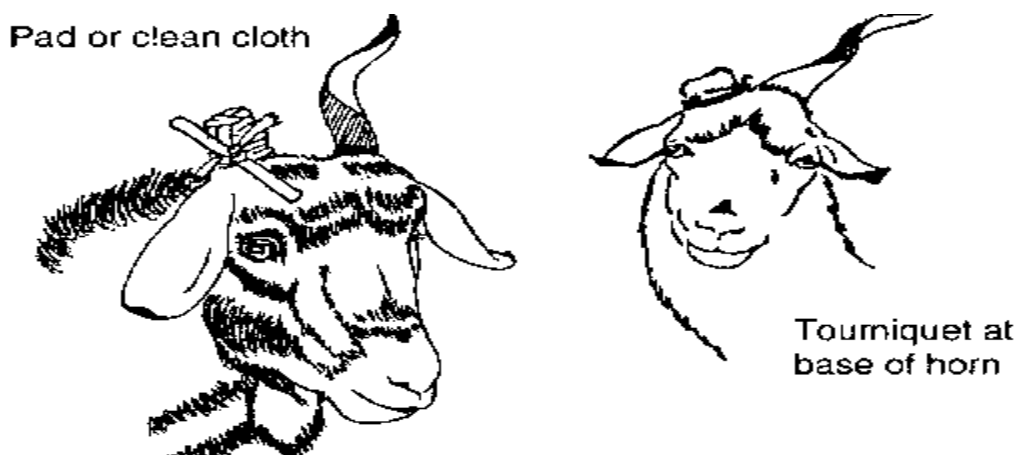

FIGURE 90: BLEEDING FROM A BROKEN HORN

Remember do not leave a tourniquet on for a long time. If bleeding continues release the tourniquet every 20 minutes and then tighten it again.

Internal bleeding

This type of bleeding is dangerous. It can be:

- From the lungs and gut after an accident
- From the uterus or vagina after giving birth

The signs of internal bleeding are that the animal becomes weak and the rate of breathing increases. An animal with internal bleeding should be placed in a quiet, warm place and should be given water with a pinch of salt in it. Do not try to walk the animal as it may collapse and die.

You will need to ask for veterinary help if you believe that an animal has internal bleeding. In many cases there is nothing you can do to stop it. It is better to slaughter the animal.

In the horse and donkey internal bleeding from the vagina can occur after birth. If you cannot get veterinary help, pack the vagina with a clean cloth or towel which has been boiled and then cooled. Leave the towel in the vagina for a day or two then remove it.

Old wounds

If wounds are left without treatment maggots will infest the wound and cause more damage.

In some cases, gangrene, will develop in a wound. The wound worsens and turns black in color with a very bad smell. Ask your veterinarian for help immediately.

Wounds from operations

Wounds can be caused by operations carried out on the animal. Wounds are caused by:

- Castration
- Docking (cutting the tail)
- Dehorning (removing the horn)
- Cutting the navel cord immediately after birth
- Cuts when the wool was sheared

All wounds should be cleaned with disinfectant. If you have a powder for wounds you should use this daily until they heal.

Infected wounds or operations often swell from pus. The swelling is soft to the touch. These wounds, called abscesses, should have the pus removed by cutting through the skin with a sharp knife or scalpel to allow the pus to drain out. Abscesses are treated daily to keep the drain incision open, squeeze out the pus and flush out the wound with clean water or liquid disinfectant. An antibiotic or sulfa drug should be given by injection or orally for 3 -5 days.

FRACTURES (BROKEN BONES)

If a bone is broken and there is no wound or bleeding it is called a closed fracture. When the bone is broken and there is bleeding this is called an open fracture.

Bone fractures in animals are difficult to treat especially in large animals.

It may be possible to successfully treat leg fractures in small, young animals.

You will need veterinary help to deal with all sorts of broken bones.

Learning objectives

After studying this unit you should know:

1. What can cause fractures.
2. Signs of fractured bones.
3. Treatment for fractures.
4. Dislocation of bones.

Cause of fractures

A fracture is a broken bone. Any one of the bones in the body can be broken but it is most common for the bones of the legs to be broken.

Fractures can result from the animal being kicked, falling, putting its leg in a hole or from fighting another animal.

How to recognize when a bone is broken

A fracture will happen suddenly; it is not like a disease which takes time to develop. Sudden pain and an abnormal movement (lameness) often mean a fracture.

The animal will be unwilling to use the part of its body where the fracture is. You may hear the sound (crack) of the two ends of the broken bone as the animal moves. The area around the closed fracture will become swollen.

In an open fracture, there will be a wound and bleeding. The ends of the broken bone may show through the wound.

Dislocation of bones

This happens when the ends of two bones (joint) move apart from each other. You can feel that the joint is dislocated when you touch it.

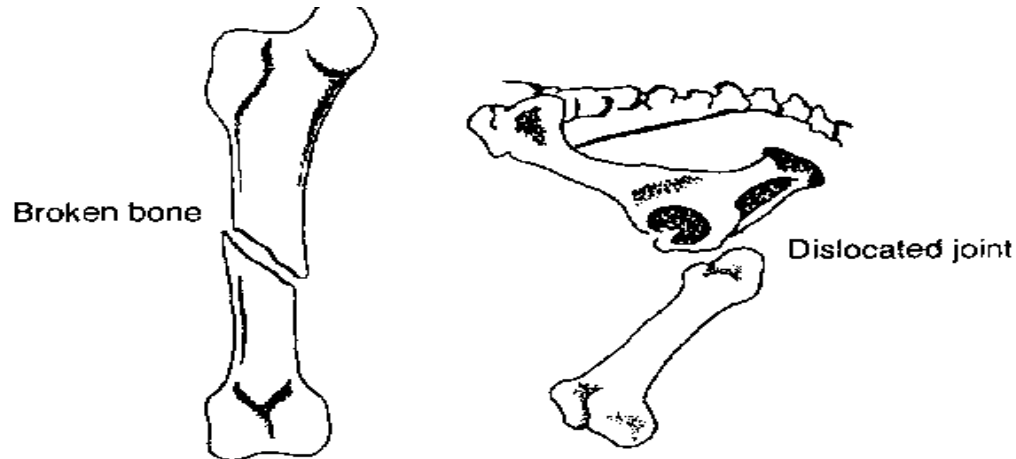

FIGURE 91: DISLOCATION OF BONES

Treatment of fractures

In the case of a large animal you must prevent the animal moving and ask for help from your veterinarian. He may decide that the animal should be slaughtered.

Broken legs commonly occur in small or young animals. It may be possible to treat. You should ask your veterinarian for help but if this is not possible ask the community health worker or the bone setter in the community to splint it. You can sometimes put dislocated bones back into place if you have someone to help you.

LUMPS UNDER THE SKIN

A lump under the skin can appear in any place on the body. Lumps may grow and increase in size or stop growing.

Some are hot and painful. Some lumps contain pus (yellowish matter) or blood.

Learning objectives

After studying this unit you should know:

1. What are abscesses.
2. Abscesses of the lymph nodes.
3. How to treat abscesses.
4. Blood lumps under the skin.
5. What are hard lumps under the skin.

Abscesses (lumps of pus)

Abscess means infection under the skin. An abscess is a swollen, red and painful lump under the skin. It contains pus (yellowish matter).

An abscess is caused by germs. Germs get under the skin by:

- Bites from other animals or insects such as ticks and flies.
- Sharp objects such as thorns or nails piercing the skin.
- Injections or vaccinations which have been done with dirty needles.
- Diseases cause abscesses. The lymph nodes (glands) can develop abscesses in some diseases

Abscesses in the lymph nodes (glands)

The lymph nodes in animals are similar to those which you have in your body under the jaw and armpits. When an animal is infected the lymph nodes (glands) often become swollen and can be felt as lumps under the skin. In some diseases this swelling becomes an abscess.

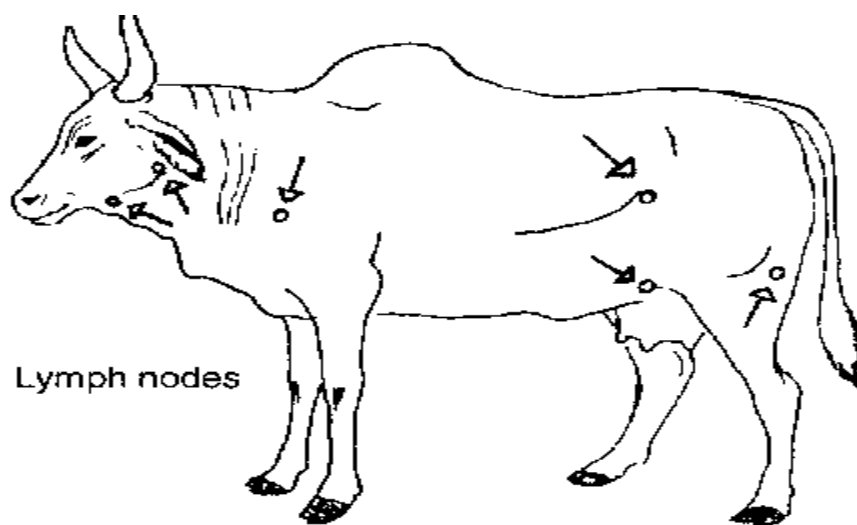

FIGURE 92: ABSCESSES IN THE LYMPH NODES (GLANDS)

Treatment of abscesses

Some abscesses will break open and the pus will come out. You may need to open an abscess and can do so when it is soft. To do this quickly you should:

- Clean the abscess and the area around it with soap and water. Stick a clean needle into the abscess. If blood comes out put the needle into another point on the abscess. If pus comes out when the needle is put into the abscess, remove the needle and with a clean sharp knife, razor blade or scalpel make a small hole through the skin into the pus pocket. Then cut downwards through the skin into the pus and allow the pus to drain out of the abscess.
- When the pus has been removed, the abscess is treated as a wound.
- If the abscess is not ready to open soak a cloth in hot water and put it over the abscess for 10 minutes at a time. You will need to do these 4 times daily for a few days until the lump has become large and soft and can be opened.

Pus contains germs. You should clean up the pus and collect it in a piece of paper or cloth and burn it. Wash the area of skin around the abscess. Wash your hands and disinfect all needles and instruments used.

If the abscess is deep under the skin and does not break and the animal has a fever, you will need to ask your veterinarian for help. Antibiotics or sulpha drugs can be given by mouth or by injection for 3 days if you cannot get veterinary help.

Do not open abscesses of the lymph nodes but give an antibiotic or sulfa drug for 3 days to treat the infection.

Lumps of blood under the skin

This will result if an animal has been kicked or beaten. The lump is soft and not hot or painful and will disappear in 2 to 3 weeks.

You should not hit animals or try to lift an animal by holding its skin. This will cause blood lumps under the skin. If you want to sell animals for slaughter this will show as red-blue areas in the meat.

Solid lumps

These are hard lumps which are not hot like abscesses or soft like blood lumps. Solid lumps may increase in size continuously or stop growing after some time. You will need to ask your veterinarian for advice on an animal which develops this type of lump.

Strangles in horses

This is an abscess of the lymph glands under the jaw in young horses, mules and donkeys. The animal has a high temperature, there is an abscess under the jaw and a thick creamy discharge from the nostrils. You must isolate the animal and get veterinary help to open this abscess.

POISONING

Animals do not normally eat poisonous plants. A lack of other feed may cause animals to eat such plants. They may eat unfamiliar poisonous plants if they are moved to a new area where there are different poisonous plants.

Poisons such as warfarin (rat poison) and strychnine can be the causes of poisoning of animals. Arsenic dips may still be used in some areas and can lead to poisoning.

Sometimes animals are purposely poisoned by people.

Snake bite is the most common form of dangerous poisoning.

Learning objectives

After studying this unit you should know:

1. Signs of poisoning in animals.
2. Causes of poisoning of animals.
3. Treatment of poisoned animals.
4. How to treat snake bites.

Signs of poisoning in animals

A poisoned animal may die suddenly or will show the following signs:

- Excessive salivation.
- The mouth is open and the tongue hangs out.

- Diarrhea and vomiting.
- Difficulty in breathing.

Causes of poisoning in animals

There are many causes of poisoning in animals:

- There are very many poisonous plants. You should talk to your community and discover what poisonous plants are in your area.
- Seeds for planting may have been treated with chemicals. If animals or humans eat these they can die.
- Strychnine is a poison which can be used to kill wild dogs and wolves. It will also poison other animals
- Weed killers used in agriculture may be poisonous.
- Chemicals used to kill insects on plants or used for dipping against external parasites.
- Old paints, kerosene, diesel and other fuels and oils.
- Poison used to kill rats and mice.
- Animals can be poisoned by salt if they are not able to drink a lot of water.

Sometimes people deliberately poison animals.

Treating poisoned animals

You cannot do much in a case of poisoning. You should ask for veterinary help as soon as possible. Try to discover what caused the poisoning and stop other animals from being poisoned.

- Charcoal mixed with water and given as a drench is a good treatment for poisoning. Give 1 g m for every 20 kg of body weight.
- Kaolin (china clay), a white powder, can be mixed with water and given as a drench. Give 10 gm to a small animal and 200 gm to a horse or camel.

Snake bites

There are numerous snakes which are poisonous to animals and man. Animals are mainly bitten in the face and legs.

Usually we discover the animal was bitten by a snake when it is too late to do anything. If you are with an animal when it is bitten, you should examine the animal and move the hair or wool to find the two small, but deep, wounds made by the fangs of the snake.

You should use a tourniquet to stop the poison from a bite on the leg going through the body. Release the tourniquet every 20 minutes to allow the blood to flow. You should send for veterinary help immediately as it will be necessary to give the animal an injection against the snake poison. Disposal of dung

The droppings or dung of domestic animals must be disposed (got rid of). Infections, e.g. parasites, can spread through dung. It will also be used by various flies as a place to lay their eggs.

Animal dung can be used to fertilise soil for crops, can be dried and used for fires or may be mixed with clay to make building materials.

Learning objectives

After studying this unit you should know:

1. How we can use animal dung.
2. Why we need to dispose of dung
3. How to safely dispose of dung.

What dung can be used for

Animal dung is used for a variety of different things throughout the world:

- Cattle dung is mixed with clay or mud to make bricks or the walls of houses.
- It is dried for fuel for fires.
- It is used as a fertiliser on soil used for growing crops.

Animal dung is an excellent fertiliser for soil and can be used to improve the quality of any soil which is used to produce crops.

Why we need to dispose of dung

Germs which cause disease and the eggs of parasites which infect the animals are present in the dung. Removing dung from where the animals are kept helps to reduce the spread of disease. If animals are kept in stables or other enclosed areas the dung must be removed regularly as it will become the breeding place for germs.

Dung will also be used by flies which will lay their eggs in it and the maggots will feed on the dung. The flies carry germs from the dung and can spread disease. Some of the flies which breed in dung bite animals and suck their blood. These flies can also spread disease, e.g. surra in camels.

Disposing of dung

Collect the dung into heaps to slowly rot. As it rots the dung produces heat which will kill germs and the eggs of parasites. The heap should be mixed and replied regularly in order that all the material it contains becomes hot.

When it is well rotted, the dung can be used to fertilize agricultural land.

Do not make dung heaps close to houses or too close to stables or other animal housing. Flies attracted to it will become a nuisance. The smell can also be unpleasant. Do not place dung heaps on land which is near to water or may be flooded when the rainy season comes. Dung can contaminate the water and spread disease to animals which drink it. If a lot of animal dung or waste enters a stream or river it can cause the death of fish.

40. HEALTH OF THE COMMUNITY

In order to be healthy, we need foods such as milk, eggs and meat which we get from animals. The animals we keep must be healthy so that the food we get from them is good for us.

When animals are kept in contact with the community, we should control where they are allowed to go, what they drink and what they eat.

Learning objectives

After studying this unit you should know:

1. How to keep animals in the community.
2. Animals and the community's water supply.
3. Handling meat, eggs and milk for the community.

ANIMALS IN THE COMMUNITY

Traditionally animals may be left to wander around the roads or between the houses in a community. They are allowed to eat whatever they can find and to drink dirty, stagnant water. This is not a good way to keep animals which can easily become sick or stolen when kept like this.

At the same time it is not good for the community as the animals can spread disease to people or spoil the community's water supply. You should talk to the people in your community and advise them of the problems which can come from keeping animals in this way. Advise them on how to house animals and take care of them.

THE COMMUNITY'S WATER SUPPLY AND ANIMALS

Your community may get its water supply from a pond, river, spring, tank, well or borehole. You should help to keep this water clean and safe to use.

- Do not allow people to throw dead animals into the water.
- Do not bury animals near the water or allow dung in or near it
- River or stream water for use by the people should be drawn up stream from the village. Boil, filter or disinfect it before use. Let animals drink water further downstream.
- If your water comes from a pond or borehole have special troughs built for the animals to drink from. Do not let animals drink directly from the pond. Animal droppings and urine will get into the water which is bad for the health of people and will spread disease amongst animals.

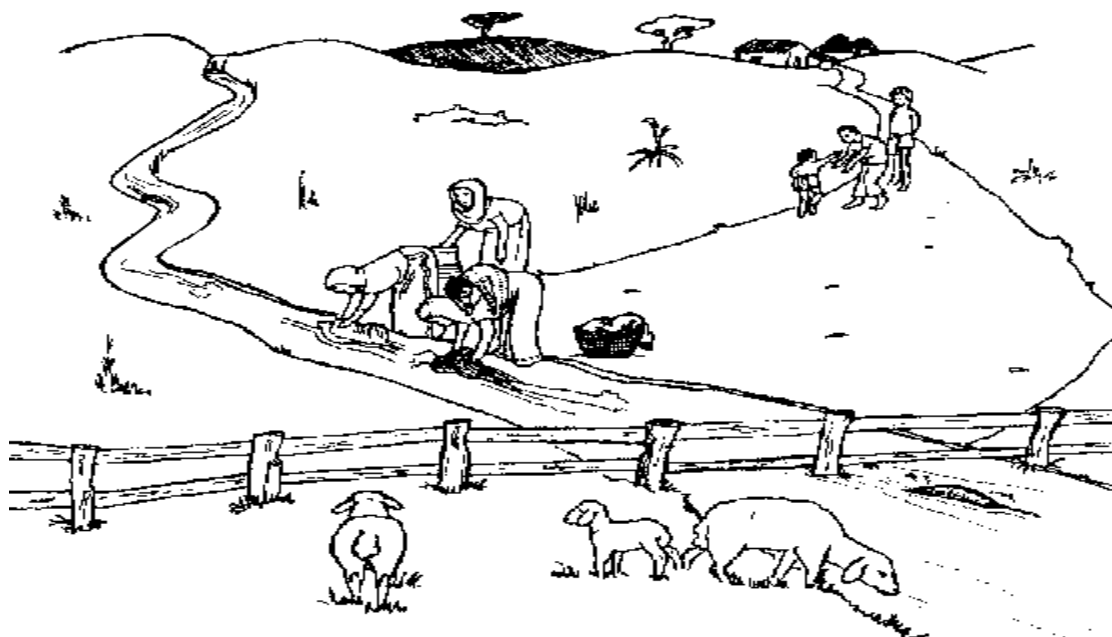

FIGURE 93: COMMUNITY'S WATER SUPPLY AND ANIMALS

SLAUGHTERING ANIMALS

Animals to be slaughtered for meat should be healthy. They should be hung during slaughtering and fully bled. The slaughterhouse (abattoir), or the place of slaughtering, should be fenced off and kept clean. Unusable animal organs and waste should be buried in a deep hole. They should not be thrown into a river or given to dogs.

MEAT FOR THE COMMUNITY

Meat should be sold separately from other foods. It must be protected from heat, flies and other animals. Hands should be washed before and after handling raw meat. Any surfaces on which meat has been placed and any knives should also be thoroughly cleaned.

Meat must be sold fresh each day or dried, salted or cooked. Dried or salted meat will keep for a long time. Cooked meat should be eaten at once or within a very short time of cooking.

Eating raw or uncooked meat can be very dangerous. Eating infected meat can cause vomiting, diarrhea, fever and sometimes death.

EGGS AND MILK

Milk is the one animal product which everyone uses in their food. It can be the source of several diseases.

Eggs provide a good body-building food. Chicken eggs may be eaten raw when fresh. Duck eggs should always be cooked before they are eaten.

SIZE AND WEIGHT OF ANIMALS

It is very important to know how much medicine you need to give to each animal. This book deals with 14 different types of animals which can be divided into groups according to their size.

Large animals:	Camel, horse, large cattle and buffalo.
Medium animals:	Small cattle, donkeys, mules, llamas and large pigs.
Small animals:	Sheep, goats, alpacas, small pigs, young cattle, young buffalo and young camels.
Very small animals:	Young sheep, goats and piglets.
Birds:	Chickens, ducks and turkeys.

DISINFECTANT FOR WOUNDS

These are usually liquids and are used to clean dirt from the wound and kill germs.

- Salt water: Add a large spoonful of salt to a litre of clean water to make a very cheap and good disinfectant for wounds.
- Acriflavine: An orange or red powder. Prepare by adding one part of powder to 1 000 parts of clean water. -This is very good for cleaning wounds and abscesses after removing the pus.
- Tincture of iodine: A dark brown liquid used to dress wounds.
- Gentian violet: A liquid for dressing wounds and burns.
- Alcohol: Clear like water, this is good for cleaning wounds and also the hands before carrying out operations e.g. castrating animals.
- Dettol and TCP (solution of phenol and sodium salicylate): Trade names for disinfectants which can be used on the animal, for your hands and instruments.

R2 DISINFECTANTS FOR ANIMAL HOUSES AND EQUIPMENT

- Hot water and soap. Carbolic soap is the best if you can find it.
- Jeyes, Chlorox and creosote can be used by adding 5 parts to 100 parts of water.

R3 DRESSINGS FOR MOUTH LESIONS (MOUTH WASH)

Use a big syringe to flush out the mouth.

- Salt and water or potassium permanganate or hydrogen peroxide.
- Copper sulphate (blue stone). Use 2 parts in 100 parts of water.

R4 DRESSINGS FOR THE FOOT

These solutions are used to kill germs causing foot rot or infecting wounds of the foot.

- Tincture of iodine or Dettol or TCP (solution of phenol and sodium salicylate).
- Copper sulphate (blue stone) use it as a 10% solution by adding 10 parts to 90 parts of water.
- Formaldehyde: This is available as a 40% solution in bottles. Add one part of this to 8 parts of water to make a solution of the correct strength.
- Chloramphenicol: A spray. This is good for use on the foot and on other wounds.

R5 ANTIBIOTIC POWDERS FOR WOUNDS

These must only be used to kill germs in wounds.

- Chloramphenicol, tetracycline or any antibiotic as a powder can be dusted over the wound.

good against both young and adult flukes.

1. INJECTIONS

There are several ways to inject animals with drugs and vaccines.

Intramuscular injections (i.m.)

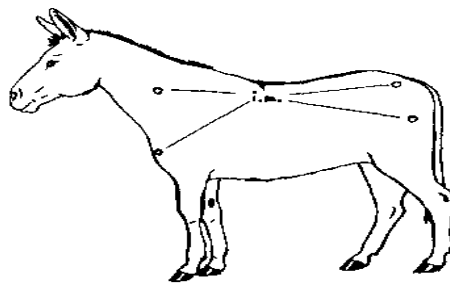

Inject into the muscle of the hip, the upper back leg, the middle of the neck, the shoulder or chest muscles. Point the needle straight into the muscle. Before injecting the drug, pull back the plunger a little to make

sure that the needle did not enter a blood vessel. If blood enters the barrel of the syringe pull the syringe out and try another place. If no blood enters the barrel inject the drug into the animal.

INTRAVENOUS INJECTIONS (I.V.)

This injection is made into the big vein (jugular) in the neck. This vein collects blood from the head and carries it to the heart.

You will need someone to help you to control the animal and to find the vein. In order to make the vein show, block it at the base of the neck. Use your hand to do this in small animals and for large animals use a rope around the bottom of the neck. Blocking the vein will make the blood build up inside it and it will stand out like a cord or rope under the skin. Put the needle into the vein. Check that the needle is in the vein by pulling the plunger of the syringe, back a little when blood should show in the barrel. Remove your hand, or the rope, from the bottom of the neck and slowly inject the drug.

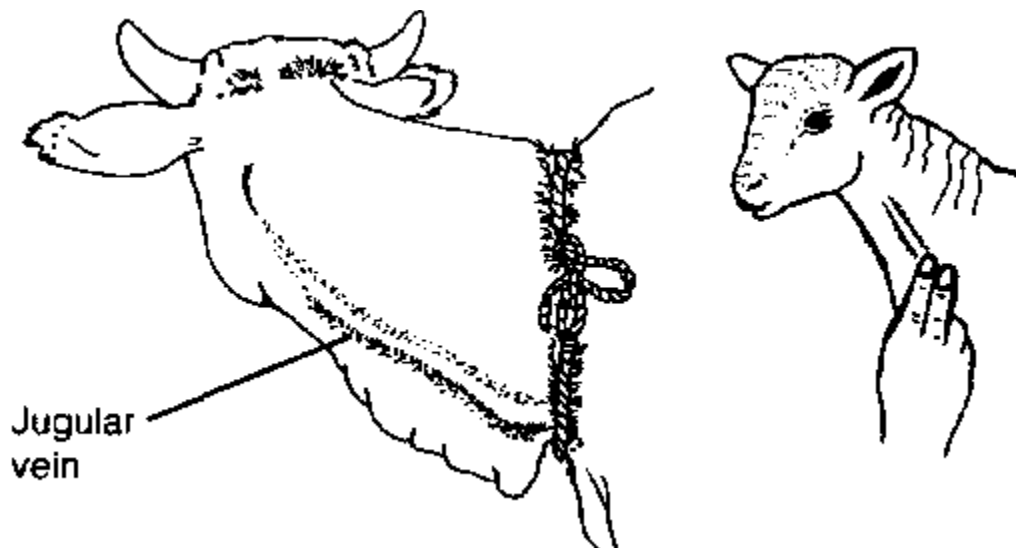

SUBCUTANEOUS INJECTION

This means injecting under the skin. It is done by picking up a loose fold of skin from the neck or shoulder. Take care not to inject into your fingers or that you push the needle in so much that it comes out on the other side of the skin fold.

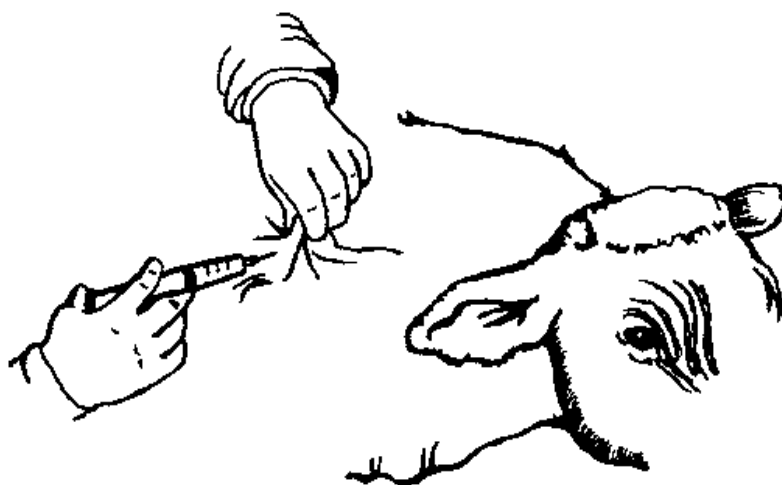

INTRAMAMMARY INJECTION

Used to empty antibiotics in an intramammary tube into the udder or to put drugs into the udder using a teat catheter.

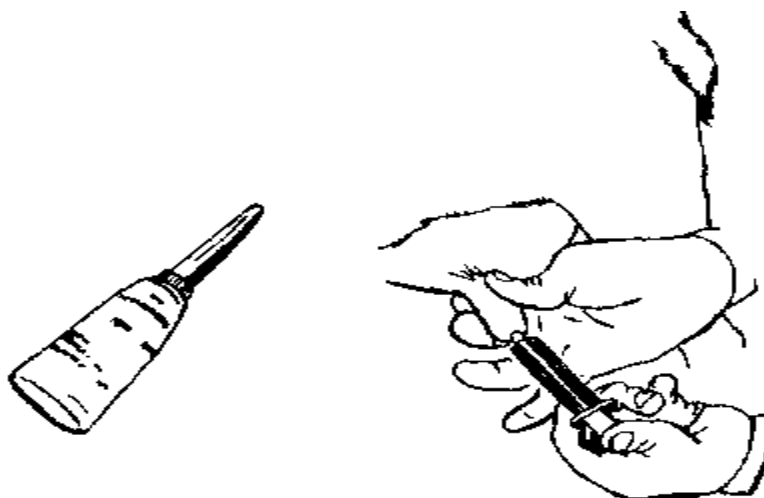

Remember that before you make any injection you should:

- Pick an area of skin free from faeces or mud
- Use a clean sterilised syringe and properly fitted needle
- Make sure your hands are clean

2.VACCINATIONS

Animals can be protected against some germs and diseases by giving them a vaccine. Vaccines are very important in stopping the spread of disease and are given by injection or by the mouth.

Some of the diseases discussed in this book, e.g. rinderpest, rabies, anthrax, African horse sickness and foot and mouth disease, can be prevented by vaccination. Some vaccines only need to be given once to the animal to protect it, but other vaccines, e.g. anthrax and foot and mouth disease, need to be given every year.

Talk to your veterinarian about the vaccines which are available and the way they must be given to the animals. You will also need to know how to keep the vaccine until it is used. Hot weather can spoil some vaccines and your veterinarian will advise you on keeping vaccines.

Remember when you vaccinate animals to change the needles after every few injections to prevent the spread of germs.

Talk to the people in your community and encourage them to vaccinate their animals. Keep records of all vaccinated animals .

.....				
Vaccine			Rinderpest	
Type (of animal)			Cattle.....	
Age of animal			6 months old.....	
Frequency (No. of times to vaccinate)			Once.....	
Route (how to give vaccine)			Subcutaneous injection	
Vaccine	Type	Age	Frequency	Route

3.DRENCHING

Animals can be given medicine by drenching. Medicine is poured into the mouth from a bottle.

Drenching must be carried out carefully to make sure that the animal receives all of the medicine it needs and that none enters the lungs where it can cause respiratory problems or death.

Drenching with a bottle

Prepare the drench to be given to the animal. The drench can be given from a bottle provided by the veterinarian or use a clean glass bottle (Pepsi or beer bottle). A short piece of rubber tubing (20 cm) can be attached to the mouth of the bottle. To drench large animals:

- Restrain the animal.
- Hold the animal's head so that it is level or only slightly raised.
- Put the rubber tube into the mouth with the end of the tube or the bottle either on the middle of the tongue or in the cheek beside the teeth. Take care to avoid getting the glass bottle between the teeth when it could be broken.
- Pour the medicine in slowly, a little at a time, allowing the animal time to swallow the liquid.

If the animal coughs at any time allow it to lower its head and stop drenching when it is coughing. Take time to drench the animal. If a very large amount of medicine, such as more than half a litre, has to be given, it can take up to 15 minutes to give all of the drench.

Sheep and goats are more difficult to drench than cattle. They should be held so that their feet remain on the ground and the nose should be raised no higher than the eyes. Drench pigs and horses very slowly.

Sheep can be given a drench using a dose syringe or by using a rubber tube attached to a funnel.

Drenching with a bottle



4.BOLUSES (TABLETS)

Medicines can be given to animals as a bolus or tablets (pills). Large animals, e.g. cattle, buffalo and camels, can be given medicine in boluses, oval or round balls of the medicine. The bolus may sometimes be contained in a plastic container which stays in the rumen and the medicine slowly comes out over many months. This type of bolus is used to give cattle drugs against worms in the gut. Sheep and goats can be

given boluses (or capsules) by using a balling gun. A pig cannot be given a bolus as it has a sort of pocket in its throat in which the medicine can become trapped.

The balling gun

A balling gun is a simple metal tube which is wider at one end to form a small container (head) in which the bolus is placed. A bar of metal or fixed rings are on the opposite side of the rod to allow the user to have a firm grip and to stop the tube being swallowed by the animal. A metal rod or plunger can be pushed through the hollow tube to push out the bolus when the balling gun has been pushed into the animal's mouth.

Giving an animal a bolus

Giving a bolus with a balling gun is done by:

- Place the bolus in the head of the gun.
- Restrain the animal to be treated and open its mouth.
- Put the balling gun way back into the mouth so that the head is placed behind the base of the animal's tongue.
- Push the plunger slowly to push the bolus out.

The animal should swallow the bolus immediately, but if it starts to choke or cough, lower its head so that the bolus drops out as it coughs.

Tablets may also be pushed over the back of the tongue by hand but you must take care not to be bitten. Wetting boli or dipping in oil makes them easier to swallow.

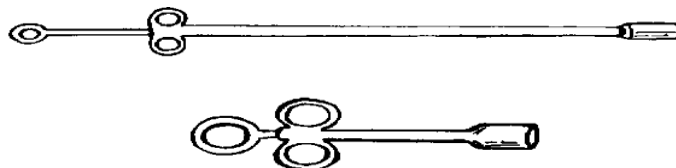

5.STOMACH TUBING

Large quantities of liquid medicine are mainly given through a long rubber tube directly into the stomach. A stomach tube can also be used in the case of bloat (tympany) to release gases from the rumen. There are different varieties of stomach tubes for animals of different sizes. You will need to practice this technique as there is a risk of the tube passing down the windpipe into the lungs and causing death of the animal.

In order to stop the animal chewing the stomach tube you will need to put a metal pipe, or a block of wood with a hole in it, into the animal's mouth. Pass the stomach tube through the pipe or the wood into the stomach. Watch the animal carefully for signs of coughing. If the animal coughs the tube is in the lungs and you must take it out immediately.

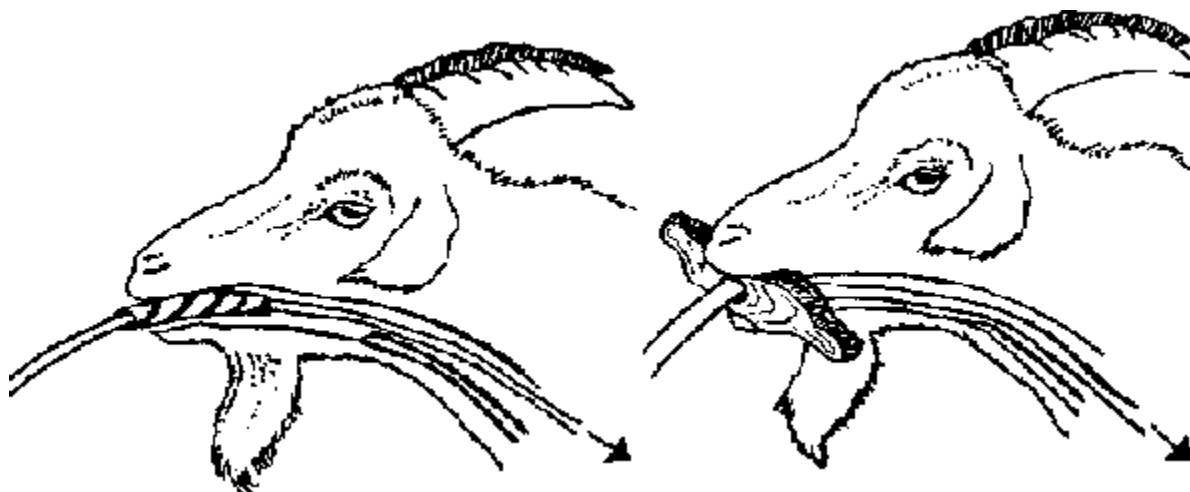

If the animal does not cough smell the end of the tube and you should notice the bad smell of stomach gases. When you are sure that the tube is in the stomach you can pour the medicine down the tube.

Do not use the stomach tube unless you have been trained to do it.

6.CLEANING THE UDDER

Many animals are kept for their milk. The value of any milk animal is reduced if it has mastitis. The condition of the udder and the cleanliness of the milk is very important for the well-being of not only the animal but also of the people who use the milk. Cleaning the udder and mastitis were described in Unit 22.

If mastitis continues in a group of animals it is advisable to use a teat disinfectant when milking them. A teat dip is a liquid in which the teat is dipped after milking the animal. After milking germs can pass into the udder through the teat canal. Dipping the teat in a disinfectant stops any germs from entering the udder and causing mastitis.

If mastitis is a problem in your community talk to your veterinarian about it. He can advise you on improving milking hygiene and the best disinfectant to use as a teat dip.

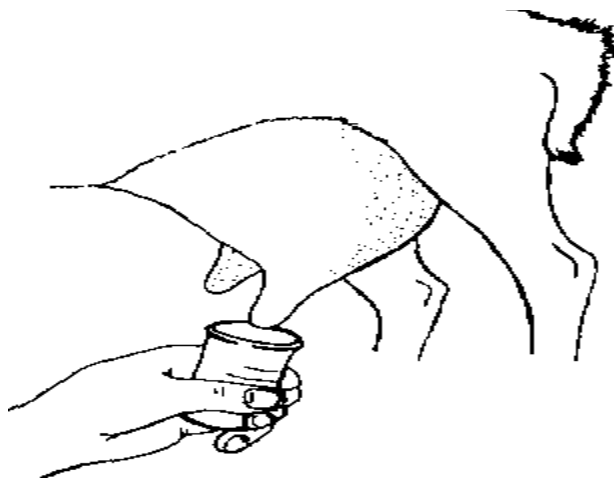

7.DIPPING

Dipping is the most efficient and practical way of treating ruminants for skin parasites. Your community or area may already have a tank for dipping which you can use or the veterinary service may have a mobile dip tank which can be taken to your community when needed. Your community may decide to construct a tank. You will need to talk to your veterinary officer for advice on what to treat animals with and how to use the tank. He will also be able to advise you on how to construct a tank.

The dipping tank

The animals are first collected in a collecting pen. They are then driven into a narrow passageway (race) which is too narrow for them to turn around. In the race is a footbath (trough of water) through which the animals walk. This removes mud from the feet before they enter the tank.

The animals are forced forward into the tank and are completely dipped in the treatment it contains. The animals walk out of the tank along another passageway (race) which has a sloping concrete floor to allow all solution dripping off the animals to run back into the tank. This race is only wide enough to take one animal at a time and can be fitted with gates to allow animals to be held and marked or given individual treatment.

The dip should have a roof to protect it from rain. It should be well fenced around so that animals cannot get at it.

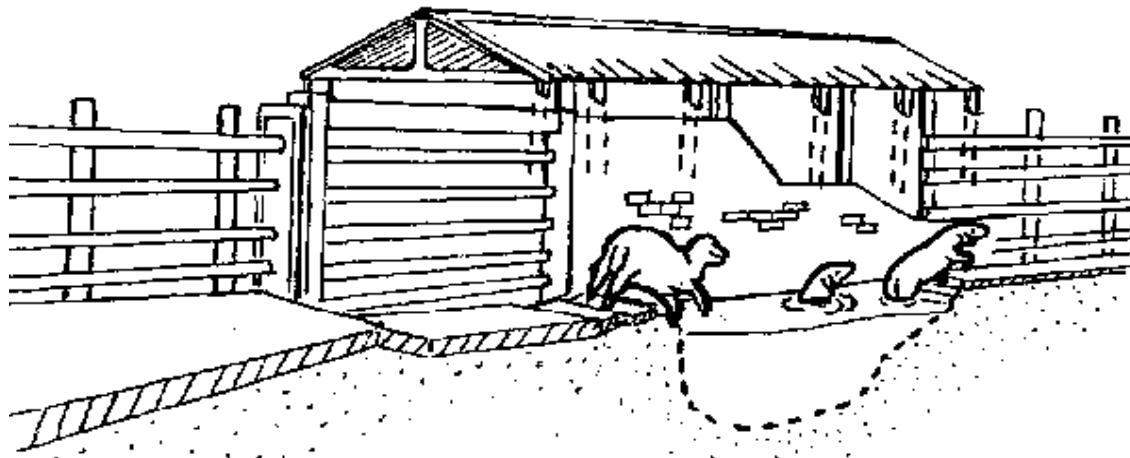

How much dip to use

For large numbers of cattle a tank that will hold 13,500 to 16,000 litres will be needed. For smaller numbers of animals a tank holding 9,000 litres will do.

When the tank is filled, the capacity (volume) of the tank can be worked out by counting the number of drums, of a known size, used to fill the tank with water. Mark the wall at intervals, or use a measuring stick, to show the amount in the tank. Add the correct amount of dip treatment to the water.

After the dip tank is used you will need to record the amount of dip left in it. Water can be lost from the tank in hot weather or rain will make the level rise. Before the tank is used again you will need to check the level of water and dip in the tank. You will need to add water and the correct amount of dip to bring the volume to the correct level again.

Using the dip

When using the dip you should always remember:

- Do not dip on cold or wet days.
- Do not dip animals when they are hot or they may drink the dip. Keep the animals in the collecting pen and allow them to drink before they are dipped.
- Always make sure that the head of each animal is pushed beneath the surface of the water and completely covered.
- Do not keep dipped, wet animals standing around. Allow the dip to drain off then move them to pasture.

- Periodically test the concentration of dip in the tank and keep it at the correct strength.
- Care should be taken to allow animals to enter and leave the tank one at a time. If they struggle to leave the tank some may be pushed under and drown.
- Do not dip small and large animals together as the larger ones can jump onto smaller ones and push them under.
- Do not dip pregnant animals that are close to giving birth. Help young animals through the tank using a crooked stick.
- Keep the footbath and races clean, clear waste material (e.g. straw) off the top of the dip after it is used.
- Always completely clean out the dip tank once or twice a year.
- Keep a record of the animals which have been dipped.

Always remember that the treatments you use can be poisonous to your animals and you if they are not used properly. Be careful when you use these treatments. Your veterinary officer will advise you when to treat your animals, what treatment to use and how to do it correctly. Always follow his advice on handling the treatments and how you can get rid of the waste.

If dip solution gets into a water supply used by animals it can cause their deaths by poisoning. If it gets into rivers, streams or ponds it will kill any fish there.

8.KNOTS AND TETHERING

A tether is the rope or chain by which an animal is tied. Ropes are used to tie up animals, to cast them and to confine them to one place.

It is important to keep a length of rope to use in your work and you must have some knowledge of the type of knots which are used to tie up or cast animals.

Non-slip knots

This type of knot is used to tie an animal with a rope around the neck or its legs. This knot will keep the rope around the neck or leg fixed and will prevent the rope from becoming tight and hurting the animal. It is also used around the neck of cattle when they are cast.

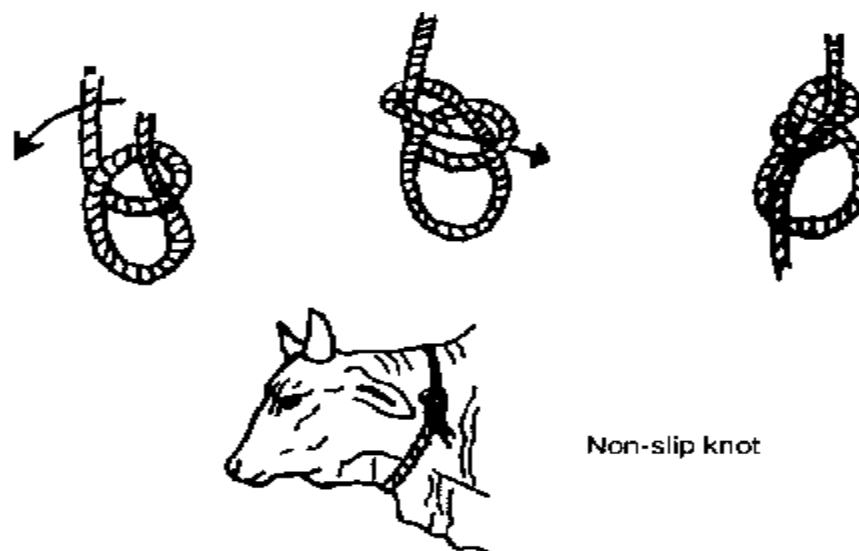

FIGURE 94: NON-SLIP KNOTS

Safety knot

Use this knot when you want to be able to quickly release a knot. Pulling the free end of the rope will quickly free the animal. Use it to tether horses or to tie together the legs of an animal which has been cast.

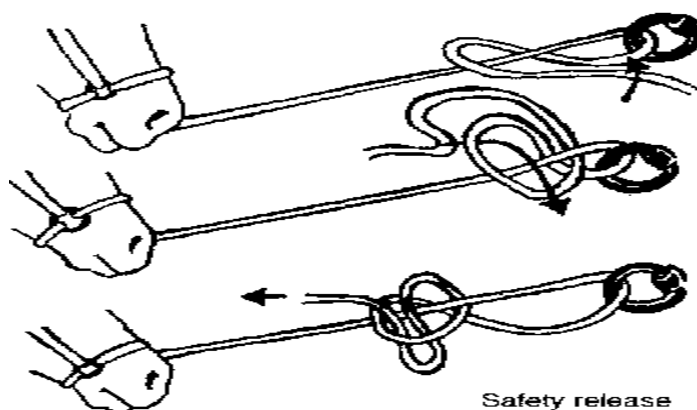

FIGURE 95: SAFETY KNOT

Double loop

This is used to make a loop in the end of a rope when making an halter to put around the head of an animal. It is also used when a rope is put around the horns of an animal to control it.

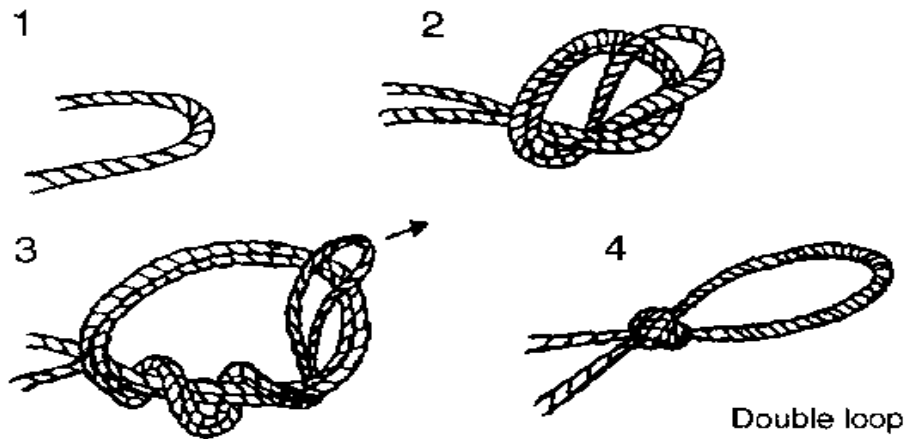

FIGURE 96: DOUBLE LOOP

Tying two ropes together

Use this when you need to join two lengths of rope together. The two ropes are held together and a loop is made towards the ends. The free ends of the rope are then passed through the loop four times and the knot is pulled tight. The ends of rope at the knot can then be cut.

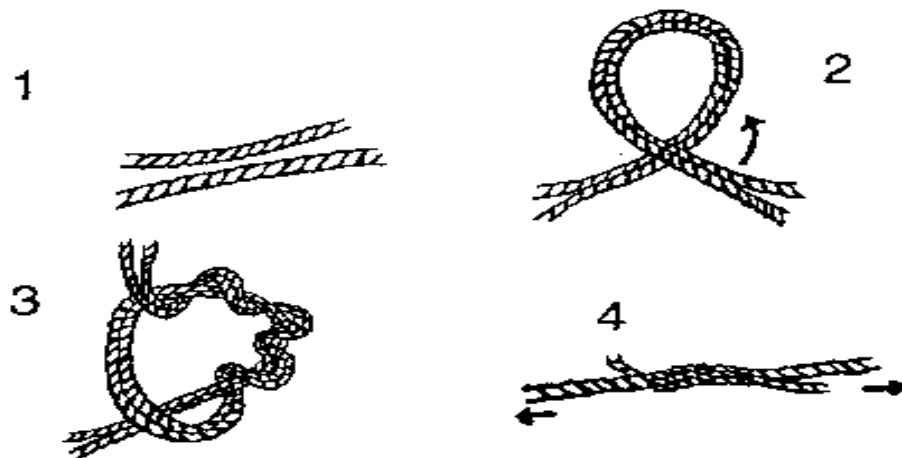

FIGURE 97: TYING TWO ROPES TOGETHER

Rolling hitch

This knot is useful when tying a rope to a Pole. It will not slip downwards.

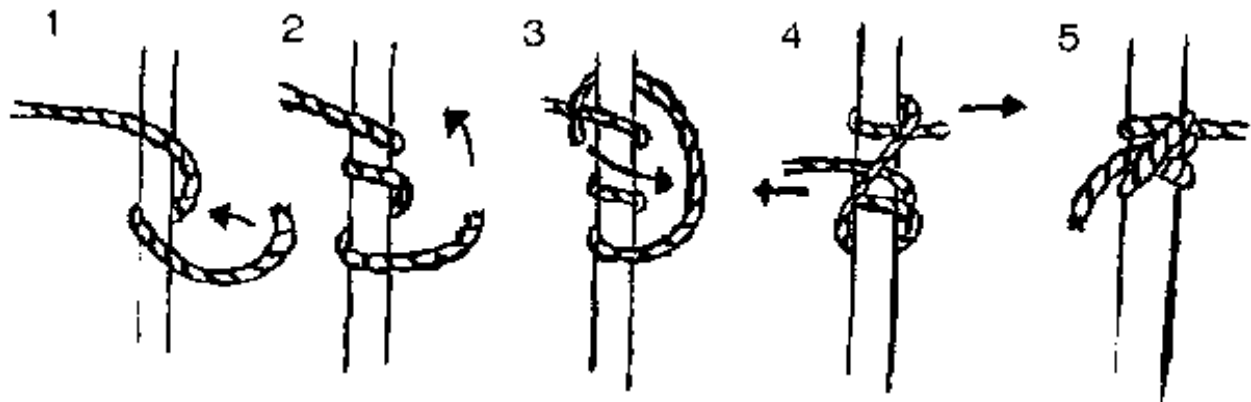

FIGURE 98: ROLLING HITCH

41. SELECTION OF ANIMALS FOR BREEDING

Breeding animals

All animals used for breeding must be fit and healthy. Good and bad qualities can be passed from the parents to the young. This is called heredity and the young will inherit characteristics from both the parents.

Why select animals for breeding?

The young animal will have the same characteristics (qualities) as its parents. Carefully choosing animals for breeding means that good, useful young animals are produced.

Animals which produce good quantities of milk can pass this characteristic to their young. Cattle and sheep which quickly grow big and fat can produce calves and lambs with the same characteristics. Selecting good males and females is the means of improving the quality of livestock in the future.

Selecting animals

The easiest way to improve your animals is by selecting a good male. In this way good characteristics can be quickly spread through the herd.

If you have ten cows and one of them is good she will produce one good calf each time she is used for breeding. If you breed the ten cows with a good bull each cow can produce a good calf. So selecting a good male will improve the quality of your herd more quickly.

When selecting animals for breeding you should take into consideration the following points:

1. BODY SHAPE

The shape of the body must be considered when choosing animals for breeding:

- The animal should be well built and its body well-proportioned and muscled. The muscles of the back will give you a good idea of the animal's condition.
- Animals with any type of deformity (bad shape) should not be used for breeding as many of the deformities can be inherited by the young. Animals with badly shaped jaws or teeth cannot be selected as this can be inherited and will mean that the animal cannot eat properly.



FIGURE 99: BADLY SHAPED JAWS

2. LEGS OF THE ANIMALS

Good legs and feet are important so that the animal can get around to feed. The legs of the female will have to carry extra weight during pregnancy. The male will have difficulty in mounting the female if its back legs are weak.

3. REPRODUCTIVE ORGANS OF MALES

The testicles and penis of the male must be correctly formed and free from deformities and infection. The testicles must be:

- Equal in size.
- Both testicles should be down in the scrotum. Do not use a male in which only one testicle is down in the scrotum.
- The larger the testicles the better.
- The testicles must be firm and not soft.

The penis of the sheep or goat can be examined by holding the male in the sitting position, as for trimming the feet. The skin around the penis can be held in one hand and the end of the penis pushed out by pushing upwards with the other hand from the base of the penis. If blood, pus or a discharge is seen, or if the penis is unusual, do not use the animal for breeding as this will spread disease to the rest of the livestock.

4. WHAT ARE THE ANIMALS USED FOR?

When selecting cows, buffalos and other animals for milk production you should select females which have good udders and teats and are docile. Docile animals let down the milk more easily than others. The amount of milk produced after the birth of the first young is important in judging the quality of a milking animal. A good male to father milk animals will be one which had a good milking mother.

When breeding animals for meat the rate at which they gain weight is an important characteristic to consider. Animals used for work should be strong, with good feet and legs and need to be docile. The parents need to show these characteristics.

The ability of the female to feed and wean her young is also important. This is an essential factor to consider when breeding pigs.

If you can keep a record of your animals you will know which ones were good for milk, meat, producing young and staying healthy. You can also keep a record of the parents.

If you keep records it will help you to judge which animals to keep for breeding and which males to castrate.

You must remember never to breed between father and daughter. This will increase the chances of any bad characteristics of the male being passed on to the young. This is called inbreeding.

42. RECORD KEEPING

1.WHY DO WE KEEP RECORDS?

As a Pashu sakhi you may well know a lot about the animals kept in your community. However, keeping the information in your memory is not enough, we can all easily forget something. You must be able to supply your veterinary and livestock officers with written papers (records) about the animals in your community.

You will need to keep records to tell you when animals were vaccinated, dipped, given any medicine or castrated. You need to know how many animals were treated, what was the problem and how often do some diseases occur in your community.

If you want to breed your livestock to improve them then you will need to keep records of the father and mother of every animal. You need to know how good they and their young were.

Records

Papers for records may be given to you by the veterinarian, livestock or agricultural officer for your area. They will want you to fill in the records with information about livestock in your community.

If you do not have these record papers you can make your own. You only need a pencil and paper. You should remember that you and your community will gain the most from record keeping.

Types of records

These are examples of the types of records you need in your work:

Recording your work in the community

It is important that you keep a register (note book) to write a record of your work:

Date	Name of owner	Age & Type of animal	Problem	Action taken
------	---------------	----------------------	---------	--------------

Vaccination record

You can keep this as a separate register or as a separate record in your notebook.

Date	Vaccination	Type of animal	Number of animals	Name of owner
------	-------------	----------------	-------------------	---------------

Records for the animal owner

You should encourage everyone who keeps animals to keep a record of their animals. Encourage them to use numbers, names or ear tags to identify their animals. If the owner keeps records of his animals he will be able to identify the good animals and breed from them and similarly he can identify the poor animals and get rid of them.

This is an example of a record for a male animal:

Name/Number of male	date of birth
Name/Number of father	
Name/number of mother	
Mating	
1. Name/number of female	date and result
2. Name/number of female	date and result
3. Name/number of female	date and result

Example of record for a female animal:

Name/Number of female		Date of Birth
Name/Number of father		
Name/Number of mother		
First mating		
1	Name/number of male	
2	Date of mating	
3	Number born	
4	Number weaned	
Second mating		
1	Name/number of male	
2	Date of mating	
3	Number born	
4	Number weaned	

43. WHAT THE TRAINER MUST DO

Before beginning the training programme, the trainer should learn about the trainees. He should know who they are, their age, where do they come from, what work do they do and if they own animals, what form of schooling have they had. He will need to discover what the trainees can already do and what they know about livestock and animal health care. He will also need to determine if they are physically able to do the work expected of them and do not suffer from any illnesses which could be passed on to other trainees.

Encouraging the trainees to talk about themselves and their background in the first training sessions (the orientation period) is very important. It helps the trainer discover more about the trainees but also allows the trainees to share and compare their experiences. From this the trainer, will learn not only the background of each individual but also what the trainees expect from the programme. The trainer may find that because of the extent of their rural or nomadic background some individuals are naturally more opinionated, and perhaps argumentative, than others. The trainer should not try to argue the point with such individuals, but having identified them, he will need to slowly change their opinions through the course of the programme by demonstration.

During the first sessions it is also necessary for the trainer to discover the extent of the trainees reading and writing skills. It can be the case that attendance at school may not necessarily have resulted in the development of these skills. Proof of these skills will be needed and the trainer will need to incorporate into the first sessions a means of testing individuals for these skills. The trainer may decide on a straight test for these skills, but it is also possible to judge the trainee's ability by participation in group sessions.

The trainer should know exactly what areas the trainees need training in and he will need to make it clear exactly what the trainees will be expected to learn. At the beginning of each unit, in this book, are a number of **Learning objectives** which state what the trainee is expected to know, or be able to do, after completing the unit. The trainer and the veterinary service may decide to use other learning objectives if it is deemed necessary for additions or deletions to be made to the programme to meet with local requirements.

The trainer will need to arrange the means by which trainees can practice the skills they are expected to develop. It will be necessary to arrange training exercises wherein the student can learn to do what the learning objective describes. Trainees must be given repeated opportunities to practice the techniques. It is often difficult to obtain animals for demonstrations. Animals can be bought in the market, used in training, then resold. Cooperating farmers may be happy to let trainees learn and practice on their animals.

44. THE CONDITIONS OF LEARNING

In order to facilitate the running of a training programme the trainer will need to carefully plan his teaching, practical arrangements and facilities. In doing this he should consider some relevant points.

The first point to consider is that the trainees come from a nomadic or rural background and will be familiar with livestock, unlike the majority of university and college students who come from towns and cities. In many cases they will have their own traditional methods of animal management and treatments which have been passed down from generation to generation, e.g. castration of livestock using red hot skewers, or using two pieces of wood to crush the testicles. Some of these ideas have been developed through necessity and are useful while others at best are useless if indeed not harmful. The trainer should encourage the trainees to discuss the various practices which are carried out in their communities. He should discuss them and praise those which are useful. He will then need to demonstrate the benefit of the methods he is expecting them to learn and encourage the trainees, through practice and discussion, to adopt the new methods. In this way trainees can be encouraged to decide for themselves that such practices as keeping old animals (perhaps because traditionally a man's wealth is judged by the size of his flocks and herds) are of no benefit and that culling old stock will release feed supplies to benefit increased numbers of younger stock.

Trainees can learn tasks only if they are given the opportunity to practice them repeatedly while under supervision. The trainer must therefore be skilled in this form of training. It is essential that the trainer and the organisation or institution providing the training arranges the means by which trainees have the opportunity to learn in this way. The training programme contains an element of work which will involve a certain amount of straight forward classroom teaching, but the overall emphasis is on practical experience.

It will be necessary for the trainer to arrange suitable facilities for training and to give the trainees access to livestock on which to practice their skills. It may be deemed necessary for some skills to be practiced away from the live animal e.g. injections can be practiced on oranges, dead animals or meat before being carried out on the live animal. It is also possible to use the dead animal in some training exercises. However, the trainer will have to make provision for young animals (lambs, calves, piglets) to be castrated and for adult animals to be restrained by trainees. It may be decided to train them to take blood samples and again it will be necessary to use a live animal.

The trainer may encounter reluctance on the part of owners to allow their animals to be used in training. It may prove necessary to use animals kept by government institutions or farms or to buy in animals for demonstrations. It may be possible to use animals prior to slaughter for some work and a visit to the abattoir can be extremely useful. Many trainees will never have seen a foetus because traditionally pregnant animals

are not sent to slaughter. However, a visit to a slaughterhouse can provide the trainer with foetuses which can be used to demonstrate the correlation between foetal development and duration of pregnancy. The abattoir can also be the source of organs, diseased or otherwise, which can be used throughout the course.

The trainer should develop a range of training material including large drawings, bones and specimens. An artificial womb can be made out of a suitably sized box and used with dead foetuses. Trainees should also be shown important veterinary tools, e.g. Burdizzo, and made familiar with them even if, for the time being, they cannot be provided with their own to take back to their community. The assumption is that they will eventually have such equipment.

The trainer will need to arrange some classroom facilities in addition to the practical outdoor facilities. He will also find that the organisation of the trainees into small groups for training will allow each trainee the chance to practice skills.

45. EVALUATING THE TRAINEE'S PROGRESS

The trainer must decide how to judge the trainee's ability to perform the various tasks. It is usual to test the trainee's skills at the end of each unit and at the end of the training programme. The best way of assessing performance is to watch the trainee perform a task and check against a list prepared by the trainer before training commenced.

In order to do this it is necessary for each complex task to be broken down into individual simple tasks. The trainer must then determine an acceptable level of performance for each component task. If a trainee fails to reach the required standard the trainer must explain why he/she has failed and then allow further opportunity for the trainee to practice these parts of the overall task. A trainer needs to remember that asking a trainee how he would perform a task and receiving a written or oral reply to the question is not a satisfactory assessment method. It does not provide the means of testing the trainee's ability to actually perform the task.

After some experience the trainer will be able to tell whether any of the objectives need to be changed or omitted, whether it is necessary to make new objectives, and if the assessment tests are satisfactory. He will also be able to judge whether the training conditions are satisfactory or will need to be changed. In this way the trainer will be able to improve on the programme.

SIMPLE AND COMPLEX TASKS

Training should be delivered by first developing proficiency in simple tasks before the trainee attempts the more complex tasks. The complex task should be divided into the component tasks and the trainee works through each component. If training and assessment are based on this, then it will be easy to identify problems that a trainee may have and allow for further practice to attain the required standard.

Using this method also allows for evaluation when trainees return for further training. It will then be possible to identify skills they have not practiced for some time and offer the opportunity for refresher training and practice.

DEVELOPING TRAINEE'S LEARNING ABILITIES

The trainer needs to help the trainees to become "self-learners", i.e. they learn by themselves, independent of a trainer, using books and by experience. In order to use books the trainee will need to read and write at least to the level needed to use this book. Provision must be made to assess literacy skills at the onset of the course and provide tuition to cover weaknesses. Some trainees will expect to receive tuition in the classroom

style they remember from their school days and expect the trainer to tell them everything. This must be discouraged and the trainer must take steps to stimulate such individuals into learning some things by themselves.

Trainees need to be numerate to allow them to make simple calculations and keep records. The trainer needs to incorporate arithmetic into the course to ensure that trainees are capable of performing the simple mathematical calculations deemed necessary in their work.

Other skills that the trainee will need are social skills, i.e. the ability to relate to others. Trainees need to develop the ability to listen respectfully to people, to encourage them to talk about problems. The trainee needs to deal respectfully but firmly with individuals and the elders and leaders of the community. Trainees will also need to be able to determine what is important and what is not and develop the skills of persuading people to do what is necessary to improve the health of the community's livestock. In some cases this may be contrary to traditional husbandry methods.

By observing the behaviour of trainees the trainer will be able to identify those who have weaknesses in social skills. It will be necessary to improve these skills and help trainees to develop greater self-confidence. A trainer will make provision for this by incorporating into the programme some time for class discussion and if necessary individual tuition in social skills. On completion of the course trainees will return to their communities and their progress should be monitored. This will ensure that those who encounter problems can be helped and also provide feedback on the success of the training programme.

EVALUATING THE PERFORMANCE OF TRAINEES AND THE SUCCESS OF THE TRAINING PROGRAMME

Trainees will be continually assessed during the training programme to determine any problems and ensure that they are given every opportunity to develop the required skills. At the same time identification of problems encountered by the trainee will indicate weaknesses in the training programme and/or the ability of the trainer to implement the programme. All tests used to assess trainees' abilities must be relevant and reliable. That is, tests should measure exactly what it is required, e.g. how much the trainee knows about a problem and what he can do about it. The test should also be objective and different independent examiners should agree on what is a satisfactory answer.

When the trainees are at work in their community, monitoring their work will indicate:

1. If what they learned is appropriate to their work.
2. If there are any problems for which they have not been trained.

3. If Pashu sakhi are working with interest and satisfaction.
4. Whether they continue in their work.
5. If the community is satisfied with the services, they offer.

46. ETHNOVETERINARY PRACTICES²¹

I HERBAL MASALA BOLUS FOR ALL DIGESTIVE PROBLEMS.

This preparation will be good for all digestive problems viz. anorexia, indigestion, off feed, absence of rumination, impaction etc.

Ingredients needed for 5 dairy animals / 10 sheep or goats are given below:

kalimirch (Black pepper) 10 gm, jeera (cumin) 10gm, dhaniya (coriander seeds) 20 gm, fenugreek (methi) 20 gm, ajwain (Trachyspermum ammi) 10 gm, ginger(adrak) 50 gm, Haldi (turmeric) 50 gm (fresh), gheekumari (Aloe vera) 100 gm, galo / batindu (Tinospora cordifolia) stem and leaves 100 gm, Lahsun (garlic) 50 gm, lallmirch (red pepper /chillies) 50 gm, Paan (betel leaves) 10 number, Kari patta (curry leaf) 100 gm, Tulsi leaves 50 gm, tarwar leaves and flowers (Cassia auriculata) 100gm, Nariyal (coconut)100 gm, gud(jaggery) 100gm, rock salt 50 gm, khaneka soda (sodium bicarbonate) 100 gm.

First grind all dry items in a mixi viz. black pepper, jeera, coriander seeds, fenugreek, ajwain, red chillies) Then grind all the fresh herbs viz. Aloe vera, curry leaf, garlic, tulsi, ginger, turmeric, coconut (grated), galo and tarwar.

After that mix together both the above items. Now add jaggery (after making into small pieces), and rock salt, (sodium bicarbonate) and mix it thoroughly.

DOSAGE:

At the end make a bolus of 100 gm each (lemon fruit size) and administer orally. It can be given monthly once preferably in empty stomach.

For young animals (calf, sheep or goat) give half the quantity or reduce the quantity according to the body weight of animals.

The above preparation will be good for all digestive problems viz. anorexia, indigestion, impaction. This will also give some relief for repeat breeding/reproductive problems, internal parasites, act as preventive medicine for Foot and Mouth Disease, Blue Tongue, fever, mastitis, Hemorrhagic septicemia.

²¹ The booklet on Ethnoveterinary Practices as reference material for Pashu sakhis has been printed with inputs from SEVA, Madurai (www.sevango.in).



gheekumari

galo / batindu

tarwar

Karipatta

II TYMPANY:

SYMPTOMS: Stomach bulged and difficulties in breathing

CAUSES: sudden change in feed materials, excess intake of legumes, dining waste

Administer 200 ml each of castor oil (*Ricinus communis*) and lukewarm water are shaken well and administered orally at an interval of 4-6 hrs for large animals.

Betel leaves (paan) 10 number, ginger (Adrak) 20 gm, pepper (kalimirch) 10 gm, garlic (Lahsun) 10 gm, rock salt 50 gm are pounded and mixed in lukewarm water and administer orally at 6 hours interval for large animals.

Reduce the quantity to small animals according to the body weight of animals



Paan

Adrak

III DIARRHEA:

SYMPTOMS: watery dung

CAUSES: Indigestion, intake of spoiled feed or eating toxic plants

Grind one handful each of tender leaves of pomegranate, tender leaves of neem, tender leaves of guava along with dried ginger 50 gm, jaggery 100 gm and make 3 bolus and administer one bolus at a time for 3 times until diarrhea gets cured.



Neem



Amrud, jamphal



Anaar

IV CONSTIPATION:

SYMPTOMS: Lack of defecation or hard pelleted dung

CAUSES: Fever, heat stress and dehydration

1. Enema can be given (boil 10 litres of water after adding 100 gm neem leaves and cooled and administer through rectum of large animals)
2. Laxatives like castor oil, liquid paraffin oil, raw lin seed oil (500ml) can be given for 1-2 days according to species and body weight of animal. Given as drench for 2-3 days or as required. A decoction of 100 gm of haldi (turmeric rhizome) in a lit. of water may be given once daily for 1-3 days to large animals.



V ENDOPARASITES (INTESTINAL WORMS)

SYMPTOMS: Animals emaciated, thick body hairs, foul smelling stools with worms

CAUSES: Round worms, tape worms, hook worms infestation

Leaves of *nirgundi* (*Vitex negundo*), *khorpad* (*Aloe vera*), Neem seeds, *kirayat* (*Andrographis paniculata*), *akamadara* (*Calotropis*) are to be taken at 1 kg each. All are to be ground well by sprinkling little water and filtered and 4 litres of herbal mixture can be obtained. This can be stored for one month. Then 30 ml of the extract is taken and administered for one adult sheep or goat. For younger sheep or goat less than 3 months old 10 ml has to be administered orally. For adult cattle 100 ml has to be administered. The dewormer arrest loose motion and result in solid dung and it is free from obnoxious odor. It increases grazing efficiency of animals and they look healthy.



Neem

Nirgundi, sindvar

Gheekumari

Madara, Aak

Batraj

VI ECTOPARASITES (LICE, TICKS, MITES)

SYMPTOMS: Presence of parasites visible all over the body, animal emaciated, dull and death in severe cases

1. Garlic, Tulsi, neem leaves, turmeric, seethapal seeds each 10-20 gm are ground together and boiled in 250 ml of neem oil and applied over the surface of the body of large animal.
2. Whole plant of Raimuniya (*Lantana camara*) is chopped and crushed and diluted with the urine of cattle 3 days and apply externally.
3. Boil tobacco stalk 250 gm in 2 lit. of water and add 5 lit. of water and sprayed over the body of 10-20 animals.



Raimuniya



Seethapal



Tobacco

VII RESPIRATORY TRACT INFECTIONS:

SYMPTOMS: Heavy snoring, difficulty in breathing

1. Take leaves of *Thulsi* (*Ocimum sanctum*) 100 gm, leaves of arusha (*Adhatoda vasica*) 100 gm, ginger 50 gm, pepper 10 gm, jaggery 100 gm and boil in 1 lit. of water and administer 100 – 250 ml of the decoction 2-3 times daily.
2. Few fruits (6-8 number) of kantakari / kateli (*Solanum surattense*) are crushed and soaked in goat urine over night and filtered and few drops are squeezed in to the nostrils.



Arusha

kantakari / kateli

VIII FOOT AND MOUTH DISEASE

SYMPTOMS: Ulcers in mouth and cleft of hooves, drooping saliva and difficult to walk

CAUSES: Virus

INGREDIENTS REQUIRED:

Turmeric 200 gm (freshly harvested rhizome is preferred), coconut kernel extract (from 1 coconut), gheekumari (*Aloe vera*) – 200 gm, palm jaggery 200 gm, common salt 100 gm, garlic 100 gm, pepper 50 gm, cumin 50 gm, fenugreek 50 gm.

The above ingredients viz. turmeric, gheekumari (*Aloe vera*), garlic, grated coconut are ground well through grinder/ mixi by using sufficient water and collected in a vessel. Then make powder of pepper, cumin, fenugreek and all ingredients are mixed together thoroughly and add sufficient water to make it about 1 liter. Then filter it and administered orally.

DOSE:

100 ml at a time for adult animals or 50 ml for young ones or sheep or goats. Before giving the treatment the animals are to be fed with banana (2 number) soaked in sesame oil (50 ml).

For treatment of wounds in the foot region:

A special wound healing *thaila* can be prepared by using following ingredients:

1. Sesame oil 1 lit, haldi (freshly harvested preferred or turmeric powder 50gm) 100gm, garlic - 50gm; neem leaves 10 gm, leaves of mehanthi (Lawsonia inermis) 10 gm, kuppi (Acalypa indica)10 gm. Ground the herbal items and mix with the oil and boil the oil well and filtered. The oil can be stored in a bottle. This thailam can be applied over the affected foot region of animals for 3 days continuously or till the point of cure.

OR

2. Coconut oil 500 ml. and Datura leaf extract 500ml are taken together and boiled in a vessel till about one hour so as to get oily texture. Then put off the fire and add 5 gm of tuutiya (copper sulphate)and stir it well. Now this *thaila* is stored in a bottle and used for all types of wounds including maggot wounds in animals.

Also feed the animal with gruel prepared by boiling with ragi, wheat and bajra flour each 100 gm -200gm with sufficient water in a vessel.



Datura



kuppi



Haldi



Gheekumari

IX MASTITIS IN DAIRY ANIMALS

SYMPTOMS: swollen, hot udder; milk discolored with pus and thread like substance

CAUSES: Microbes

Ingredients required:

1. Gheekumari (Aloe vera) - 2 or 3 petal.
2. Haldi (Turmeric) powder- 50gm
3. Chunna (Lime stone)- 10 gm

All the above ingredients are ground well and made in to a paste apply over the udder thrice a day for 3-7

days depending upon the disease incidence. Before applying, the udder and teats should be washed with boiled water for 3 times for 5 days. Administer orally 50 gm of khaneka soda (sodium bicarbonate) in the juice of lemon (4 fruits) dissolved in 200 ml of water.



Gheekumari



Haldi

X INFERTILITY

For animals suffering repeat breeding, infertility or suboestrus or not coming to heat the following method has to be followed.

Administer orally Gheekumari (Aloe vera) 1-2 petals for 3 days in the empty stomach. Administer orally sprouted chana dal (bengal gram) or sprouted bajra or sprouted wheat (200 gm daily) for 15 days. When signs of oestrus cycle is noticed administer orally neem oil 100-150ml before taking the animal for insemination or natural crossing.



Chana dal



Gheekumari

XI RETENTION OF PLACENTA:

SYMPTOMS: Non – shedding of placenta beyond 3-5 hours post-partum

1. The leaves of two sesame plants (*Sesamum indicum*) about 250 gm are pounded with 1000 ml of water and drenched; placenta would be shed in 1 to 2 hour.
2. Take Bada goksur (*Peadlium murex*) plant about 200 gm, pound and soaked in 1000 ml of water and stir well and drenched.



sesame plants

Bada goksur

XII PROLAPSE OF THE UTERUS

TREATMENT: Clean the mass with sugar added water or any antiseptic lotion. Lift the mass by placing banana leaf with both hands (special care must be taken to avoid laceration or tear with nails, and hand must be washed in the antiseptic lotion). Mostly the urinary bladder will be filled. After lifting of the mass urine will easily go out and the mass will easily go inside.

Leaves of Chhui-Mui (*Mimosa pudica*) whole plant two handfuls are ground well and mixed with 200 ml goat's milk to be administered orally for three times (morning, evening and next day morning). Keep the animal in a slightly slanting position in such a way that keeping the head portion in a lower level atleast for a week.



Chhui-Mui

XIII BLUE TONGUE DISEASE IN SHEEP AND GOATS

During rainy season, sheep farmers face economic loss due to sudden death of sheep by a new disease called as blue tongue disease.

Symptoms: ulcer in the mouth, oozing of fuzz like substance from the mouth and limping while walking and sometimes in the lying position. If the animal is lifted the hairs in the body will fall off. Animals will not take feed but drink little water. In the severity of the disease the animal will die on 15th day or so.

This disease is caused by a virus and mosquitoes or insects act as vectors.

Since the animal is not taking any feed the starvation may lead to death. So, the animal has to administered orally the following recipe. Banana fruits smeared with sesame oil and fed to animals for 2 to 3 times. Half a litre of oil with 20 bananas are sufficient to treat 20 sheep. By this animal will recover little. However, this will not control the disease fully. Next the leaf pulp of Aloe vera (100 gm) has to be administered daily. Administering of Aloe vera has to be continued for more days till the animal fully recovers from this disease.

Administering Aloe vera also increases the body weight of animals as it acts as dewormer against all intestinal parasites. This can also be administered as preventive treatment on monthly interval especially during rainy season.



Gheekumari

XIV POISONOUS BITE OR FOOD POISONING:

Leaves of betelvine, tulsi, pepper, dried ginger each 10 gm. are pound together and mixed in warm water and administered orally. For poisonous bite, few drops of this extract are instilled to the eyes of the animal.



Paan



Tulsi

XV EYE INJURIES

Leaves of *bimba* (*Coccinia grandis*) or castor (*Ricinus communis*) is crushed by mixed with a pinch of salt and the juice is applied for few drops in the eyes.



bimba

castor

XVI WOUNDS

Prepare special *thaila* (oil) and apply over the wound: Coconut oil 250 ml. and Datura leaf extract 250ml are taken together and boiled in a vessel till about one hour so as to get oily texture. Then put off the fire and add 2.5 gm of copper sulphate and stir it well. Now this *thaila* is stored in a bottle and used for all types of wounds including maggot wounds in animals.

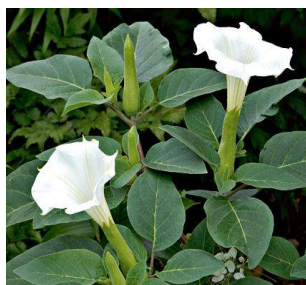

Datura leaf

XVII PANCHAGAVYA FOR ANIMAL HEALTH

This preparation overcome problems of infertility or repeat breeding.

Mix 5 products of cow (dung, urine, milk, curd, ghee) together by taking 1 kg of cow dung, 1 lit of milk, 1 lit of curd, 1 lit cow urine, 100 gm of ghee together. In addition add 2 banana, sugarcane juice 1litre are added in a plastic barrel and allow them for 1 week for fermentation. Now administer 200 ml-300 ml of

panchagavya monthly once for general upkeep of cattle or 100 ml for sheep or goat on monthly basis . For dogs affected with skin disease (oozing of body fluid from the skin) can be given by administering 100 ml of *panchagavya* for 3 days continuously. For poultry birds mix about 50 ml of *panchagavya* along with feed for feeding a dozen birds. *Panchagavya* fed chicken lay eggs of bigger size and also the growth of the bird is quick and faster.

XVIII MILK FEVER OR CALCIUM DEFICIENCY:

The disease usually occurs in dairy animals caused by decrease in blood-calcium level, generally within 48 hours after calving.

Take 1 kilo of lime (Calcium hydroxide) and put in a mudpot. Add 20 litres of water and keep it overnight. Take 200 ml of supernatant water (top watery layer) and feed the animal daily. While taking the upper layer of water add equal quantity of fresh water of 200 ml daily. Every 20 days change the whole content.

This practice can be followed regularly and it prevents diseases caused due to calcium deficiency

XIX POULTRY DISEASES

a. FOR RANIKHET DISEASE:

Symptoms Diarrhea, excreta is watery, green with foul odor; discharge from the nose; coughing and sneezing; swelling of the head; head and neck twisted to one side; drooping wings, dragging legs; sleepiness; full, distended crop; convulsions and paralysis; death.

Precaution : The disease affected chicken are to be removed and kept separately.

Leaves of *utarn* (*Pergularia daemia*) 20 gm, leaves of *kirayat* (*Andrographis paniculata*) 20 gm, fresh haldi (turmeric: *Curcuma longa*) 20 gm, garlic 20 gm and onion 20 gm are chopped together and fed with other poultry feed occasionally as preventive or curative treatment.



Utarn



kirayat



Haldi

b. FOR LICE INFESTATION OF POULTRY :

Symptoms: Small, white lice lay eggs on the feathers; lice moving on skin and feathers; reduced egg production; slower weight gain; birds constantly peck at themselves or scratch themselves with their beak.

Spread crushed leaves of *sithapal* (*Annona squamosa*) or *calotrpis* inside poultry nest and lice collected over the leaves can be disposed off hygienically.

Garlic, Tulsi, neem leaves, seethapal seeds, haldi (turmeric) each 10-20 gm are ground together and boiled in 250 ml of neem oil and applied over the surface of the body of 10-15 birds.



Sithapal



Haldi



Lasun



Neem



Tulsi