

# **“Guidelines for Environmental Management of Dairy Farms and Gaushalas”**



**Central Pollution Control Board**  
(Ministry of Environment, Forest and Climate Change, Govt. of India)  
**Parivesh Bhawan, East Arjun Nagar**  
**Delhi-110032**

**Revised**  
**(July 2021)**

## CONTENT

	<b>Page</b>
1. Background	03
2. Categorization of Dairy Farms and Gaushalas	04
2.1 Dairy Farms	04
2.2 Gaushalas	04
3. Environmental Issues in Dairy Farms and Gaushalas	04
3.1 Dairy Farms	04
3.1.1 Urban & Peri-urban Area	04
3.1.2 Rural Area	05
3.2 Gaushalas	05
3.2.1 Urban & Peri-urban Area	05
3.2.2 Rural Area	05
4. Methods for Disposal/Utilization of Dung	05
5. Guidelines for Waste Management in Dairy Farms	06
5.1 Guidelines for Waste Management in Dairy Farms located in Urban & Peri-urban Area	07
5.1.1 Solid Waste Management	07
5.1.2 Wastewater Management	07
5.1.3 Air Quality Management	08
5.1.4 Siting Policy	08
5.2 Guidelines for Waste Management in Dairy Farms located in Rural Area	08
5.2.1 Solid Waste Management	08
5.2.2 Wastewater Management	09
5.2.3 Air Quality Management	09
5.2.4 Siting Policy	09
6. Guidelines for Waste Management in Gaushalas	10
6.1 Solid Waste Management	10
6.2 Wastewater Management	10
6.3 Air Quality Management	11
6.4 Siting Policy	11
7. Regulatory/Monitoring Mechanism for Dairy Farms & Gaushalas	11
Annexure-I:- BIS: 12237-1987	13
Annexure-II:- BIS: 11799-2005	19
Annexure-III:- BIS: 11942-1986	31
Annexure-IV: Inventory Performa for Dairy Farms and Gaushalas in the State/UT	50

## 1. Background

India ranks first among world's milk producing Nations since 1998 and has largest bovine population in the World. Dairying has become an important secondary source of income for millions of rural families and has assumed most important role in providing employment and income opportunities particularly for marginal farmers.

Dairy farms are establishment which in-house milching animals to produce milk for distribution or supplying milk to milk processing plants (other than own consumption).

Gaushalas are establishment which in-house weak, sick, injured, handicapped and abandoned homeless cattle/cows to rehabilitate them. Different terminology is used for Gaushalas in different states like Gosadans, Pinjrapole, etc.

As per 20<sup>th</sup> Livestock Census carried out by Department of Animal Husbandry, Dairying & Fisheries, Ministry of Agriculture and Farmers Welfare, in 2019, state-wise total population of bovine by sex and in urban & rural area is as follow:

Sl. No.	State/UT	Male Bovine	Female Bovine	Total Bovine in Rural Area	Total Bovine in Urban Area	Total Bovine
1.	A & N Islands	10,899	29,239	37,916	2,222	40,138
2.	Andhra Pradesh	15,73,589	92,45,997	1,03,97,667	4,21,919	1,08,19,586
3.	Arunachal Pradesh	3,06,246	4,13,583	7,03,018	16,811	7,19,829
4.	Assam	33,77,705	79,53,249	1,11,05,707	2,25,247	1,13,30,954
5.	Bihar	18,15,419	2,13,02,355	2,23,53,630	7,64,144	2,31,17,774
6.	Chandigarh	3,370	22,247	8,927	16,690	25,617
7.	Chhattisgarh	52,00,444	59,58,232	1,07,13,966	4,44,710	1,11,58,676
8.	Dadar & Nagar Haveli	27,015	13,718	39,223	1,510	40,733
9.	Daman & Diu	587	1,627	1,637	577	2,214
10.	Delhi	34,868	2,13,707	2,39,796	8,779	2,48,575
11.	Goa	18,081	69,373	78,940	8,514	87,454
12.	Gujarat	25,20,220	1,76,56,667	1,93,89,940	7,86,947	2,01,76,887
13.	Haryana	7,48,898	55,47,807	58,27,031	4,69,674	62,96,705
14.	Himachal Pradesh	4,99,630	19,76,892	24,47,638	28,884	24,76,522
15.	Jammu & Kashmir	5,45,636	27,10,666	31,55,710	1,00,592	32,56,302
16.	Jharkhand	51,33,373	74,39,992	1,21,84,691	3,88,674	1,25,73,365
17.	Karnataka	20,39,509	94,14,055	1,08,00,819	6,52,745	1,14,53,564
18.	Kerala	2,07,111	12,36,389	13,15,665	1,27,835	14,43,500
19.	Lakshadweep	785	1,724	2,509	0	2,509
20.	Madhya Pradesh	71,00,049	2,19,57,910	2,76,69,875	13,88,084	2,90,57,959
21.	Maharashtra	53,06,297	1,42,89,699	1,88,97,723	6,98,273	1,95,95,996
22.	Manipur	87,062	1,82,699	2,37,699	32,062	2,69,761
23.	Meghalaya	3,53,580	5,65,704	9,11,065	8,219	9,19,284
24.	Mizoram	15,775	35,992	38,434	13,333	51,767
25.	Nagaland	59,057	58,016	1,09,716	7,357	1,17,073
26.	Odisha	42,66,720	60,95,574	1,00,34,984	3,27,310	1,03,62,294
27.	Puducherry	4,695	69,684	57,322	17,057	74,379

28.	Punjab	3,47,572	61,99,835	60,99,440	4,47,967	65,47,407
29.	Rajasthan	30,06,285	2,46,24,661	2,65,18,272	11,12,674	2,76,30,946
30.	Sikkim	36,209	1,18,164	1,51,972	2,401	1,54,373
31.	Tamil Nadu	8,14,996	92,22,459	89,12,712	11,24,743	1,00,37,455
32.	Telangana	19,09,034	65,49,811	81,46,252	3,12,593	84,58,845
33.	Tripura	1,24,505	6,21,657	7,08,228	37,934	7,46,162
34.	Uttar Pradesh	45,52,599	4,74,83,827	4,95,30,075	25,06,351	5,20,36,426
35.	Uttarakhand	5,50,595	21,67,900	25,34,526	1,83,969	27,18,495
36.	West Bengal	44,35,306	1,52,73,592	1,91,76,146	5,32,752	1,97,08,898
<b>All India</b>		<b>5,70,33,721</b>	<b>24,67,24,703</b>	<b>29,05,38,871</b>	<b>1,32,19,553</b>	<b>30,37,58,424</b>

## 2. Categorization of Dairy Farms and Gaushalas

Dairy Farms/Gaushalas are categorised on basis of nos. of bovine animals in a Dairy/Gaushala located in urban, peri-urban & rural area.

### 2.1 Dairy Farms

According to inventory received from SPCBs/PCCs and it is analysed that 60-70% Dairy Farms are having upto 25 animals, 15-20% Dairy Farms are having upto 100 animals and 15-20% Dairy Farms are having more than 100 animals. Therefore, they have been categorized as small, medium & large Dairy farm, respectively. It has been analysed that 5-10%, 5-10% and 80-90% Dairy Farms located in urban, peri-urban & rural area, respectively.

### 2.2 Gaushalas

Similarly, inventory received from SPCBs/PCCs for Gaushalas and it is analysed that 15-20 % Gaushalas having upto 100 animals and 80-85% Gaushalas having more than 100 animals. Therefore, Gaushala having upto 100 animals, 1000 animals & more than 1000 animals can be categorized as small, medium & large Gaushala, respectively. It has been analysed that 50-55%, 5-10% and 35-45% Gaushalas located in urban, peri-urban & rural area, respectively.

## 3. Environmental Issues in Dairy Farms and Gaushalas

Major environmental issues of Dairy farms and Gaushalas are related to disposal of dung and urinal wastewater. Poor handling & disposal of dung and wastewater causes water pollution & odour problem. A Bovine animal, on an average, weigh 400 kg and discharges 15-20 kg/day of dung and 12-14 litres/day of urine. Solid wastes produced from Dairy farms and Gaushalas are bovine dung, feed residue, etc. which are organic and non-hazardous in nature but requires proper handling and disposal.

### 3.1 Dairy Farms

#### 3.1.1 Urban & Peri-urban Area

Majority of Dairy Farms are in clusters. Issue of disposal of dung & wastewater from Dairy farms is predominant in urban & peri-urban area where it is discharged in drains, leading to clogging, which ultimately reach to and pollute rivers. These clogged drains become

breeding ground for mosquitoes creating health hazards and odour nuisance. Wastewater is generated from floor cleaning, bathing of animals, urine, etc. and disposed of without treatment into drains. Dung produces many gases/compounds such as carbon dioxide, ammonia, hydrogen sulphide, methane, etc. which emitted into atmosphere and responsible for odour.

### **3.1.2 Rural Area**

Dairy farms located in rural area are run by small & marginal farmers which produces milk for self-consumption and excess sell in local market. Dung being utilized as a manure in field. Problem arises when dung is stored for very long time and create odour. Wastewater generated majorly from urine which is generally disposed of without treatment into land due to unpaved floor or goes to nearby drain.

## **3.2 Gaushalas**

### **3.2.1 Urban & Peri-urban Area**

Dung is generally stored for very long time and creating odour issues. Sometimes, it finds its way to drains also. Dung is utilised as a manure in field and also in making dung wood/dung cakes. Wastewater is generated from floor cleaning, bathing of animals, urine, etc. Bathing of animal is done occasionally & floor cleaning is done mechanically. The urine usually discharges in drain without any treatment. However, it is also utilized for medicinal uses. Therefore, wastewater generated per bovine animal from Gaushalas is comparatively lower than Dairy Farms.

### **3.2.2 Rural Area**

Dung is being utilised as a manure in field and also used as fuel for domestic purpose. Problem arises when it stored for very long time and creating odour issues. Wastewater is generated from floor cleaning, bathing of animals, urine, etc. Bathing of animal is done occasionally & floor cleaning is done mechanically. The urine usually discharges in drain without any treatment. However, it is also utilized for medicinal uses.

## **4. Methods for Disposal/Utilisation of Dung**

Disposal of bovine dung is biggest challenge in dairy farms and gaushalas. However, bovine dung, if effectively utilised, can be a resource of manure & energy. Bovine dung may be used for many purposes i.e. for combustion (dung wood) or for producing biogas or as soil conditioner or as fertilizers or as material for wall plastering, etc. Following methods for disposal/utilisation of solid wastes (dung) may be adopted:

- a. **Composting/Vermicomposting**: Composting is a manure management practice to reduce impact on the environment. Composting is biological decomposition and stabilization of organic material. The process produces a final product that is stable, free of pathogens, reduced odours and can be applied on land as manure. Vermicomposting is method of preparing compost with use of earthworms that enriches soil quality by improving its physicochemical and biological properties. It is becoming popular as a major component of organic farming system.

- b. *Biogas/Compressed biogas (CBG) production*: Biogas plants are best way to handle dung waste. Biogas is generated in process of biodegradation of organic materials under anaerobic conditions which may be utilised for cooking and power generation. Biogas plant generated digested organic manure for crops. Biogas can be processed and filled in cylinders. Bio-gas may be further purified to remove hydrogen sulphide (H<sub>2</sub>S), carbon dioxide (CO<sub>2</sub>) & water vapour and compressed (known as Compressed Bio Gas, CBG) which has methane (CH<sub>4</sub>) content of more than 90% as per BIS standard IS 16087:2016. CBG has calorific value and other properties similar to CNG and hence can be utilized as green renewable fuel as replacement of CNG in automotive, industrial and commercial areas.
- c. *Manufacture of dung wood or dung cake to be used as fuel*: Bovine dung can be used as fuel as a replacement of firewood. Bovine dung can be dewatered and converted to value added products such as logs, powder etc. by mechanized/semi-mechanized machines.

Following options for disposal/utilization of dung may be adopted by Dairy Farms and Gaushalas:

Sl. No.	Dairy Farms/ Gaushalas	Methods for Disposal/Utilization of Dung
1.	Small Dairy Farms	<ul style="list-style-type: none"> <li>• Composting/vermicomposting, or</li> <li>• Manufacture of dung wood/dung cake, or</li> <li>• Combination of both</li> </ul>
2.	Medium Dairy Farms	<ul style="list-style-type: none"> <li>• Combination of any of three methods for disposal/utilization of dung</li> </ul>
3.	Large Dairy Farms	<ul style="list-style-type: none"> <li>• Biogas/compressed biogas production or</li> <li>• Combination with any of remaining method</li> </ul>
4.	Dairy Farms in Rural Area	<ul style="list-style-type: none"> <li>• Composting/vermicomposting, or</li> <li>• Manufacture of dung wood/dung cake</li> </ul>
5.	Dairy Farms in Cluster	<ul style="list-style-type: none"> <li>• Common Biogas/compressed biogas production, and</li> <li>• Any of remaining method at individual level</li> </ul>
6.	Small & Medium Gaushalas	<ul style="list-style-type: none"> <li>• Combination of any of three methods for disposal/utilization of dung</li> </ul>
7.	Large Gaushalas	<ul style="list-style-type: none"> <li>• Biogas/compressed biogas production or</li> <li>• Combination with any of remaining method</li> </ul>

## 5. Guidelines for Waste Management in Dairy Farms

Following guidelines are framed for management of wastes from Dairy farms. These guidelines are applicable to establishment which are discharging their wastes into environment. These establishments shall also follow existing laws, rules, guidelines, directions and standard operating procedures issued by different organizations.

## ***5.1 Guidelines for Waste Management in Dairy Farms located in Urban & Peri-urban Area***

### ***5.1.1 Solid Waste Management***

Guidelines to be followed for management of solid wastes are as under:

- i. Dung from floor of shed should be collected at regular interval, so as to keep floor clean. Surrounding areas should also be cleaned regularly to prevent obnoxious smell in area.
- ii. Premises and its surrounding areas should be properly sanitized and disinfected, e.g. by sprinkling crushed lime.
- iii. Dung & fodder residue etc. should not be washed into drains in order to avoid clogging of drains. Local bodies/corporations/SPCBs should ensure that untreated wastes are not discharged outside premises.
- iv. Collected solid wastes should be stored properly for its utilization.
- v. Small Dairy Farms may adopt dung for manufacture of dung wood/dung cake or composting/vermicomposting or combination of both methods for disposal/utilization of solid wastes. In case of cluster, biogas/compressed biogas production may be adopted for disposal/utilization of solid wastes in association with entrepreneurs or local dairy farmers association. Local bodies/corporations/SPCBs should facilitate Dairy farmers/entrepreneurs/NGOs in setting up of individual or common utilization facilities.
- vi. Medium & Large Dairy Farms may adopt a combination of disposal/utilization methods like manufacturing of dung wood or biogas generation or vermicomposting. However, Large Dairy Farms may setup biogas/compressed biogas production facility either by themselves or in association with entrepreneurs.
- vii. Domestic hazardous wastes (vaccines, vials, medicines, syringes, etc.) should be disposed as per provisions of “Solid Waste Management Rules, 2016”. If they have their own medical facilities then wastes should be disposed as per provisions of “Bio-medical Waste Management Rules, 2016”.

### ***5.1.2 Wastewater Management***

Guidelines for management of wastewater are as follow:

- i. Water should be judiciously used for bathing of bovines and other services including floor cleaning to contain wastewater quantity to 100 litres/day/bovine.
- ii. Adequate infrastructure should be provided to ensure proper handling, treatment and disposal of wastewater. They may set-up individual or common treatment facilities where in cluster. Local bodies/corporations/SPCBs should facilitate Dairy farmers/entrepreneurs/NGOs in setting up of individual or common treatment facilities.
- iii. Wastewater should be adequately treated so as to meet standards as prescribed by SPCBs/PCCs.
- iv. Flooring of shed should be properly paved (impervious) with a wastewater collection system. However, floor should not be slippery in order to ensure safety of animals.

### ***5.1.3 Air Quality Management***

Guidelines for management of air quality/emissions are as follow:

- i. Animal housing should be ventilated allowing sufficient supply of fresh air to remove humidity, dissipate heat and prevent build-up of gases such as methane, carbon dioxide, ammonia, etc.
- ii. Good housekeeping practices like maintaining proper sanitary conditions, protecting dung from unwanted pests/insects should be followed in order to minimize odour nuisance.
- iii. Floor, feeding, water and air spaces available for each animal should be adequate for standing, resting, loafing, movement, feeding, watering and ventilation. Space requirements should be provided as per Bureau of Indian Standards (BIS) (refer BIS: 12237-1987 given at **Annexure-I**).
- iv. It is suggested to obtain ration advisory for improving/modifying quality and dosage of feed/forage/supplements from any of agricultural institutes/departments like Krishi Vigyan Kendra, State Dairy Department, Animal Husbandry Department, NDRI, NDDDB, etc. in order to reduce enteric methane generations from livestock. It is beneficial to animal health/nutrition and reduced impact on environment.
- v. Plantation of trees or green belts, wherever feasible, to provide a barrier against the spread of foul smell or noise originating from them.

### ***5.1.4 Siting Policy***

Siting criteria will be applicable for new establishment. Existing establishments should take appropriate environmental friendly practices as per Guidelines. Dairy farm shall be setup as per siting policy/guidelines of local administration and may follow criteria as below:

- i. It should be located in area wherever permissible and atleast 100 meters away from residential dwellings, health centres/hospitals & schools in order to avoid odour problem,
- ii. Atleast 200 meters away from water spread area of major watercourses like Lake, canal and major drinking water sources,
- iii. Away from flood plain area of River and areas having shallow groundwater.
- iv. Atleast 5 meters of inter-se distance between two establishments (each establishment should provide 2.5 meters from each side) for ventilation should be provided and developed green belt.

## ***5.2 Guidelines for Waste Management in Dairy Farms located in Rural Area***

### ***5.2.1 Solid Waste Management***

- i. Dung should be collected & stored properly for its utilization. It should be used as compost in field or in making dung wood or vermi-compost. Biogas production may be practiced wherein cluster as a source of energy for rural area.



- ii. Dung & fodder residue should not be washed into drains in order to avoid clogging of drains and surrounding areas should also be cleaned regularly to prevent obnoxious smell in area.
- iii. Provisions of “Solid Waste Management Rules, 2016” should be followed for disposal of domestic hazardous wastes (vaccines, vials, medicines, syringes, etc.).

### **5.2.2 Wastewater Management**

- i. Water should be judiciously used to contain wastewater quantity to 100 litres/day/bovine.
- ii. Floor should be paved and wastewater should be collected and utilized for agriculture purpose. Floor should not be slippery in order to ensure safety of animals.
- iii. Wastewater should be adequately treated so as to meet standards as prescribed by SPCBs/PCCs.

### **5.2.3 Air Quality Management**

- i. Animal housing should be ventilated allowing sufficient supply of fresh air to remove humidity, dissipate heat and prevent build-up of gases.
- ii. Good housekeeping practices should be followed in order to minimize odour nuisance.
- iii. Floor, feeding, water and air spaces available for each animal should be adequate for standing, resting, loafing, movement, feeding, watering and ventilation. Space requirements should be provided as per Bureau of Indian Standards (BIS) (refer BIS: 11799-2005 given at **Annexure-II**).
- iv. It is suggested to obtain Ration advisory for improving/modifying quality and dosage of feed/forage/supplements from any of agricultural institutes/departments like Krishi Vigyan Kendra, State Dairy Department, Animal Husbandry Department, NDRI, NDDDB, etc. to reduce enteric methane generations from livestock.
- v. Plantation of trees or green belts, wherever feasible, to provide a barrier against spread of foul smell or noise originating from them.

### **5.2.4 Siting Policy**

Siting criteria will be applicable for new establishment. Existing establishments should take appropriate environmental friendly practices as per Guidelines. Dairy farm shall be setup as per siting policy/guidelines of local administration.

These should be located away from residential dwellings/hospitals/schools in order to avoid odour issue as per siting norms of local administration. It should be atleast 100 meters away from water spread area of major drinking water sources in order to avoid contamination of water bodies. These should be away from flood plain areas of River and areas having shallow groundwater.

Atleast 5 meters of inter-se distance between two establishments for ventilation, this space of 5 meters (2.5 meters from each side from each unit) shall be developed for green belt.

## **6. Guidelines for Waste Management in Gaushalas**

Following guidelines are framed for management of wastes from Gaushalas located in urban, peri-urban & rural area. These guidelines are applicable to establishment which are discharging their wastes into environment. These establishments shall also follow existing laws, rules, guidelines, directions and standard operating procedures issued by different organizations.

### ***6.1 Solid Waste Management***

Guidelines to be followed for management of solid wastes are as under:

- i. Dung from floor of shed should be collected at regular interval, so as to keep floor clean. Surrounding areas should also be cleaned regularly to prevent obnoxious smell in area.
- ii. Premises and its surrounding areas should be properly sanitized and disinfected, e.g. by sprinkling crushed lime.
- iii. Dung & fodder residue etc. should not be washed into drains in order to avoid clogging of drains. Local bodies/corporations/SPCBs should ensure that untreated wastes are not discharged outside premises.
- iv. Solid wastes should be stored properly for its utilization in dung wood manufacturing or biogas generation or vermicomposting. In case of small & medium scale Gaushalas, a combination any of methods may be adopted for utilization of dung wherein large scale Gaushalas may setup biogas generation facility at its own or in partnership with entrepreneurs.
- v. Domestic hazardous wastes (vaccines, vials, medicines, syringes, etc.) should be disposed as per provisions of “Solid Waste Management Rules, 2016”. If they have their own medical facilities then the wastes should be disposed as per provisions of “Bio-medical Waste Management Rules, 2016”.

### ***6.2 Wastewater Management***

Guidelines for management of wastewater are as follow:

- i. Water should be judiciously used for bathing of bovines and other services to contain wastewater quantity to 50 litres/day/bovine. (As water utilized by Gaushala is less in comparison to Dairy Farm due to occasional bathing & mechanized floor cleaning).
- ii. Adequate infrastructure should be set-up to ensure proper handling, treatment and disposal of wastewater. Local bodies/corporations/SPCBs should facilitate Gaushala owners/entrepreneurs/NGOs in setting up of treatment facilities.
- iii. Wastewater should be adequately treated so as to meet standards as prescribed by SPCBs/PCCs or utilized for various medicinal purpose.
- iv. Flooring of shed should be properly paved (impervious) with a wastewater collection system. However, floor should not be slippery in order to ensure safety of animals.

### **6.3 Air Quality Management**

Guidelines for management of air quality/emissions are as follow:

- i. Animal housing should be ventilated allowing sufficient supply of fresh air to remove humidity, dissipate heat and prevent build-up of gases.
- ii. Good housekeeping practices like maintaining proper sanitary conditions, protecting dung from unwanted pests/insects should be followed in order to minimize odour nuisance.
- iii. Floor, feeding, water and air spaces available for each animal should be adequate for standing, resting, loafing, movement, feeding, watering and ventilation. Space requirements should be provided as per Bureau of Indian Standards (BIS) (refer BIS: 11942-1986 given at **Annexure-III**).
- iv. It is suggested to obtain Ration advisory for improving/modifying quality and dosage of feed/forage/supplements from any of agricultural institutes/departments like Krishi Vigyan Kendra, State Dairy Department, Animal Husbandry Department, NDRI, NDDB, etc. to reduce enteric methane generations from livestock.
- v. Plantation of trees or green belts, wherever feasible, to provide a barrier against spread of foul smell or noise originating from them.

### **6.4 Siting Policy**

Siting criteria will be applicable for new establishment. Existing establishments should take appropriate environmental friendly practices as per Guidelines. Gaushala shall be setup as per siting policy/guidelines of local administration.

These should be located atleast 100 meters away from residential dwellings/schools/hospitals in order to avoid odour issue and away from the water spread area of major drinking water sources. These should be away from flood plain areas of River and areas having shallow groundwater. Atleast 5 meters of inter-se distance between two establishments for ventilation, this space of 5 meters (atleast 2.5 meters from each side from each unit) shall be developed for green belt.

## **7. Regulatory/ Monitoring Mechanism for Dairy Farms & Gaushalas**

- i. Local authorities/corporations should carry out inventory of Dairy farms and Gaushalas located in their jurisdiction in inventory performa given at **Annexure-IV** and same should be updated & shared with concerned SPCB/PCC on annual basis (calendar year wise).
- ii. Local bodies/municipal corporations shall publish a public notice in newspapers and on their website for registration of Dairy farms and Gaushalas as per municipal laws. Registration may be done preferably through online mode and same may be displayed at their websites.
- iii. SPCBs/PCCs shall publish a public notice for Dairy farms & Gaushalas to obtain consent to establish and consent to operate under Water Act, 1974 as well as Air Act, 1981 as per the categorization of industries in Orange and Green Category, respectively.
- iv. SPCBs/PCCs/local bodies/municipal corporations shall upload Environmental Guidelines on their website and also circulate to all Dairy farms and Gaushalas.

- v. Concerned SPCBs/PCCs/local bodies/corporations should monitor dairy farms and gaushalas on regular basis to ensure proper disposal of bovine dung and wastewater to check compliance of environmental norms. SPCBs/PCCs will consider carrying capacity of surroundings while allowing a new establishment and laying down environmental norms.
- vi. SPCBs/PCCs shall carry out environmental audit of atleast 2 Dairy farms and 2 Gaushalas, randomly selected from each district of State/UT and submit compliance and action taken report to CPCB on half yearly basis.
- vii. SPCBs/PCCs shall submit status of compliance of guidelines by Dairy farms and Gaushalas located in their jurisdiction in form of report once in six months to CPCB for Audit purpose.
- viii. CPCB shall carry out environmental auditing of 4 Dairy farms and 4 Gaushalas in each State/UT, randomly selected based on information received from SPCBs/PCCs on annual basis.
- ix. In case of any violation of environmental norms under Water (Prevention and Control of Pollution) Act, 1974, Air (Prevention and Control of Pollution) Act, 1981 and Environmental (Protect) Act, 1986 by Dairy farms and Gaushalas, concerned SPCBs/PCCs should impose environmental compensation as per CPCB methodology for “Environmental Compensation to be levied on Industrial Units”, for damaging the environment and in order to stop polluting activity and initiate prosecution for repeatedly polluting units.
- x. SPCBs/PCCs should provide training and consultation to Gram Panchayat for implementation of guidelines in their jurisdiction. Gram Panchayat should ensure implementation of guidelines by Dairy farms and Gaushalas falling under their jurisdiction for handling and management of wastes.
- xi. Hands on practical trainings on environment/waste management & treatment technologies, scientific feeding for enteric methane reduction, waste to wealth management programme, etc. should be provided to Dairy & Gaushala workers/entrepreneurs by local bodies/SPCBs/PCCs on regular interval.

\*\*\*\*\*

UDC 631-223:24-012

IS : 12237 - 1987

(Reaffirmed 2004)

*Indian Standard*

## RECOMMENDATIONS FOR LOOSE HOUSING SYSTEM FOR ANIMALS

- 1. Scope** — This standard recommends the layout and constructional details of loose housing system for animals.
- 1.1** Various features covered in this standard are primarily meant for herd size of 50 adult cows or buffaloes.
- 2. Terminology** — For the purpose of this standard, the following definitions shall apply.
- 2.1 Loose House** — Animal house comprising of an open paddock or yard with a shelter having common watering and feeding facilities and in which animals are kept untied.
- 2.2 Paddock or Yard** — An open area surrounded by walls, fences or rails for accommodating cattle. This area is meant to provide open air exercise to the animals.
- 2.3 Shelter** — This is a covered area, normally one-third of the area of the paddock and is located in the middle or along one side of the latter. This is the area where the animals may take protection from direct sun or rain.
- 2.4 Feeding Arrangements** — These comprise of common manger normally situated along the long axis of the covered area or sometimes an additional one in the open area.
- 2.5 Watering Arrangements** — These comprise of water tanks made as partitioned portions of feed manger or as separate units in the open area.
- 3. Selection of Site**
- 3.1** The housing system should meet the provisions given under 3.1 to 3.4 of IS : 11786-1986 'Recommendations for cattle housing for an average farmer'.
- 3.2** The site shall be such that the longer axis of the wall of the shed should be oriented east to west in all areas except temperate Himalayan and hilly regions. In coastal and desert areas, the longer axis of the shed shall be oriented across the prevailing wind direction in order to protect the roof from being blown off by high wind and at the same time to provide sufficient air movement in the shed. In sub-mountainous region, the buildings should be so sited as to avail of the natural aeration and drying. The site shall be away from other buildings.
- 4. Herd Size** — A 50-cow or buffalo dairy farm normally comprises of 35 to 40 cows, buffaloes, 10 to 15 dry animals, 35 to 40 male and female or 15 to 20 female calves, 20 to 25 growing female stock of 1 to 3 years age, 1 or 2 bulls and 2 or 3 pair of bullocks.
- 5. Building Units** — In general, the buildings can be grouped into following three categories:
- Buildings in which there is maximum labour activity, frequent handling of animals and need for closer and constant supervision, such as milking shed, milch animal shed, down-calver sheds (maternity pens), suckling calf shed and milk house.
  - Buildings in which there is lesser labour activity, no routine handling of animals and less need for closer supervision, such as dry animal-cum-bullock shed, young stock shed and bull shed.
  - Accessory sheds where no animals are housed but activities relating to feeding and management of stock are performed, such as stores for ration and dry fodder, chuffing shed and silos.
- 6. Layout**
- 6.1 Arrangement of Buildings** — Economization of space without sacrificing free flow of air and natural lighting or making conditions cramped for animals, should be the broad guideline in arranging the different buildings on a dairy farm. As far as possible, buildings within each group may be

Adopted 30 December 1987

© September 1989, BIS

G-3

BUREAU OF INDIAN STANDARDS  
MANAK BHAVAN 9 BAHADUR SHAH ZAFAR MARG  
NEW DELHI 110002

Livestock Structures and Equipment Section, Committee, AFDC 17 (28:18) 1

IS : 12237 - 1967

arranged together, with the buildings of group mentioned under 5(a) getting the most central and most approachable area. The buildings of group mentioned under 5(c) should be close to or have easy access to the feeding area of the animal shed.

**Note** — Shady trees planted and protected in the open area and around the buildings are essential ingredient of loose housing system.

6.2 Typical layouts comprising the various units are given in Fig. 1 and 2 for guidance.

**Note** — These layouts can be modified depending upon size and shape of available land, topography of land, finances, special needs, etc. However, such modifications may not be contrary to the general principles given in 5, 6 and 7.

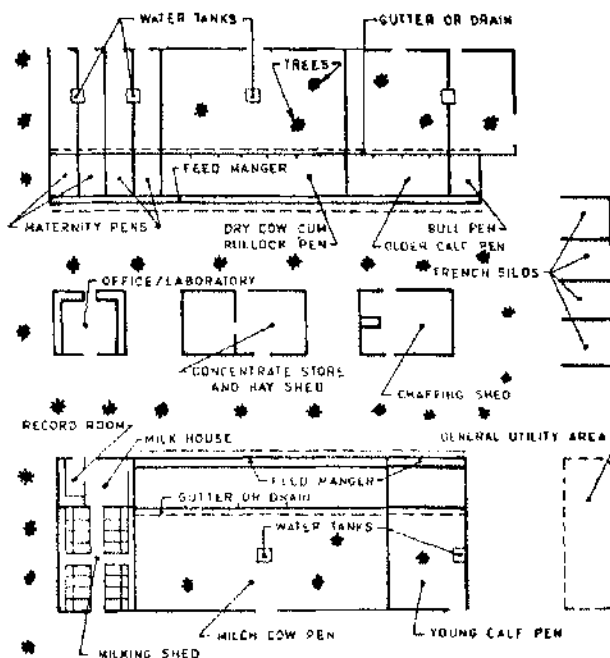

FIG. 1 LAYOUT SHOWING THE FUNCTIONAL DETAIL OF LOOSE HOUSING IN THREE ROWS

## 7. Description of Sheds

7.1 *Milking Shed* — This is a fully covered barn type building in which lactating cows are milked. It should be located at a central place with all other buildings arranged around it. There should be individual standings or stalls or stanchions in two rows in a tail-to-tail arrangement. Each standing can be used for milking 3 to 5 cows or buffaloes in one hour under hand milking conditions; the number of standings required on a farm, thus, will be about one-fourth of the number of milch animals. The length and width of the standing shall be decided according to the size of the animals and may vary from 1.6 to 1.7 m in length and 1.05 to 1.20 m in width. The width of the central passage shall be 1.5 to 1.8 m. The central passage shall have a gentle slope from the centre outwards towards the drain. There shall be two continuous mangers, one on each side along the heads of standing rows and a 0.75 m wide feeding alley beyond each manger. There shall be a shallow U-shaped drain 20 cm wide, one on either side of the central passage.

7.1.1 The floor of the standing should be paved with a slope of 1 in 40 towards drains. There should be walls along the length and at each end of the shed to support the beams or the roof. The roof of the shed should be gabled. The eaves of the roof shall project out at least 50 cm away from the side walls. The side walls need not necessarily be complete; large open spaces may be left in the side walls at suitable intervals. When walls are complete up to the roof, as is necessary intervals. When walls are complete up to the roof, as is necessary in cooler and/or heavy rainfall areas, there shall be windows and ventilators at suitable places in the walls.

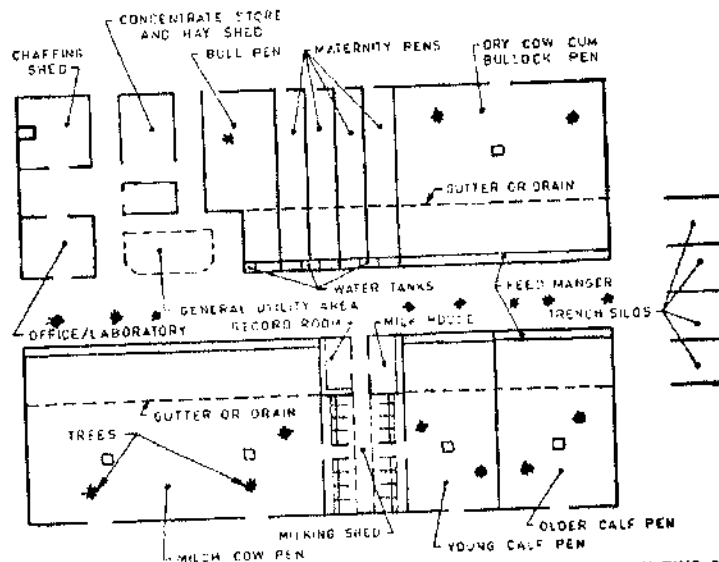

FIG. 2 LAYOUT SHOWING THE FUNCTIONAL DETAIL OF LOOSE HOUSING IN TWO ROWS

**7.1.2** Some device should be arranged to secure individual animal by neck in each standing. The milking barn may, if necessary, be extended to accommodate down-calvers as well as calves. Milch animal, that are in heat, can be left after milking in the standings and inseminated right there.

**7.2 Sheds for Milch Dry Animals** — These are sheds for housing milch animals and dry animals separately. On small farms, a partition can be raised in one shed for housing dry animals separately. On farms with only a few animals, all the animals, milking or dry can be housed together.

**7.2.1** These are simple sheds composing a covered portion and an adjoining open paddock. The manger and water tank should also be provided. The covered area should preferably be of cement concrete, brick-on-edge, stone slab, *Maorum* or *Kankar*, flooring may be used.

**7.3 Maternity Pens** — Pregnant cows are to be transferred into maternity pens or calving boxes two to three weeks before the expected date of calving. The number of calving boxes of maternity pens required is about 5 percent of the number of breedable female stock on the farm. These should be located near the living quarters of farmer and/or milking barn so that the down-calvers are constantly observed. The pens can be constructed either in a row or in groups of two or four.

**7.3.1** The dimensions of each calving pen shall be about 3 × 4 m for covered area and another 3 × 4 m for the open paddock. The covered area shall have a 1.25 m high wall all around, barring a 1.2 m wide gate opening into the open lot. A manger and a water trough of proper size should be constructed in each pen. The floors shall be *Maorum*, brick-on-edge or cement paved with a 1 in 40 slope towards the drain.

**7.4 Sick Animal Sheds** — Sheds more or less similar to maternity pens in structure shall be located well away from the other sheds so that these sheds are inaccessible to other animals.

**7.5 Calf Shed** — The calf shed can be located either at the end or on the side of the milking barn. This facilitates calves to their dams quickly at milking time (if weaning is not practised), and hand feeding of milk to calves if weaning is practised. If there is a large number of calves, the calf shed shall form a separate unit, but shall be located near to milking barn, so that calves of different age groups can be housed separately.

**7.5.1** The dimensions of calf shed depend on the number of calves to be housed. The dimensions of mangers and water troughs shall conform to specifications given in 8.2. Floors shall be of cement concrete in covered area and brick-on-edge in open area.

IS : 12237 - 1987

**7.6 Young Stock Shed** — Older heifer calves from about six months of age to breeding age are to be housed separately from the suckling calves. Generally, no male calves are kept on farms beyond six months of age. When a large number of young stock is there, they should be divided into different age groups and each group housed separately.

**7.6.1** When their number is small, the young stock shed may be an extension of the dry animal shed or it may be a separate unit nearer to it. In the latter case, the shed shall be constructed in a single row. The constructional details of this shed are the same as for cow sheds except for the difference in dimensions of mangers and water troughs.

**7.7 Bull Sheds** — The bull sheds should be constructed towards one end of the farm. There shall be one shed for each bull, the number of bulls required being one for every 50 breedable females on the farm, if natural breeding is practised. When artificial insemination service facilities are available nearby, there may be no necessity to keep bulls on the farm. The bull shed shall have covered area of 3 × 4 m dimensions, leading into a paddock of 120 m<sup>2</sup>.

**7.8 Trees** — Shady trees, preferably quick growing, may be chosen for planting in and around animal sheds. Leaves and pods of many of these can be used as cattle feed. The following species may be considered:

- a) *Acacia arabica*
- b) *Acacia leucophloea*
- c) *Madhuca longifolia* or *Madhuca indica*
- d) *Cassia fistula*
- e) *Cordia dichotoma*
- f) *Erythroxylon monogynum*
- g) *Ficus bengalensis*
- h) *Ficus religiosa*
- j) *Helicteres isora*
- k) *Kydia calycina*
- m) *Leucaena leucocephala*
- n) *Mangifera indica*
- p) *Saxif tebrasperma*
- q) *Syzygium jabolatum*
- r) *Tamarindus indica*
- s) *Wrightia tictoria*

**7.8.1** As far as possible, existing trees of the site proposed for construction should not be destroyed but incorporated within the layout. Further, trees should be planted at pre-determined spots within the layout even before the construction is completed, and the same may be nurtured and protected by tree guards.

## 8. Constructional Details

**8.1 Floor** — It shall be in accordance with 7.1.1 of IS : 11799-1986 'Recommendations for cattle housing for a rural milk producer'.

**8.2 Manger** — The manger shall meet the provisions of 7.1.2 of IS : 11799-1986 except that the wooden planks are not recommended for its construction.

**8.3 Water Supply** — Water troughs or tanks should be constructed in each shed for the convenience of animals. The water troughs should be built with reinforced concrete, bricks with cemented junctions, stone slabs with cemented joints or plain thick galvanized iron sheets. The water tanks may be round (generally in larger pens) or rectangular and shall be located at a convenient place in the shed. Its dimensions shall be more or less the same as for mangers for different classes of livestock. A two metre wide paved platform shall be provided adjacent to the water troughs. In smaller pens, a tank can be made by raising an impervious partition towards one end of the continuous manger. Each water tank should have one hydrant, the outflow from which may be controlled by a float valve. The hydrant can also be left without a tap, and water let into the troughs at regular intervals so that the water trough may get filled as the animals empty them. Hydrants with spouts to attach a hose pipe should also be fixed in each shed at convenient places. The pens and animals (buffaloes) can be washed by flushing water through a hose. Wherever possible, the water supply pipe lines should run underground.



### 8.4 Manure Disposal

**8.4.1 Liquid manure** — The liquid manure and wash water should be taken out of the shed by a shallow U-shaped gutter or drain located longitudinally to the long axis of the shed at the junction of the open and the covered area. Outside the shed, liquid manure from each shed can be lead by means of drains (preferably closed or sub-terrain drains) to a main farm drain. This main drain leads liquid waste ultimately to a liquid manure storage tank through an inspection chamber and a settling chamber. The drains should be constructed out of the same materials as that of floors. The width of the drains may vary between 30 to 40 cm. A slope of 1 to 40 should be provided to the drains towards storage tank so that the liquid may flow down easily. Shallow U-shaped drains are preferable. Drains in a row of pens should be made continuous by routing them through holes in the intervening partition walls.

**8.4.2 Solid manure** — When solid manure is collected separately, it should be stored properly in manure pits so that the same gets well decomposed. Manure pits should be located as far off as possible from animal habitations after duly considering the labour required in transporting manure from the sheds to the pits. This is necessary as a safeguard against foul odours existing near milk parlours and as a measure against fly menace. For reasons of hygiene, manure pits should be at a minimum distance of 10 m from wells, rivers and tanks and from the boundary of the adjoining land property. Further, they must be impermeable to water. The size and the number of manure pits required depend on the production of manure on the farm. Total manure storage capacity may be planned on 33 kg per day or 0.045 m<sup>3</sup> on per animal basis.

**8.5 Pillars** — Provisions given in 7.3 and 7.3.1 of IS : 11799-1986 should be followed.

**8.6 Walls and Roofs** — These should be in accordance with 7.2 and 7.4 of IS : 11799-1986, respectively.

**8.7 Paddock and Shelter** — The paddock and shelter of each shed should form an integrated unit so that the animals can move freely to any part of the paddock shelter combine. The sheltered regions should be paved while the paddock may be left unpaved, but well rammed. The space per animal shall be as given in Table 1.

TABLE 1 SPACE OF PADDOCK AND SHELTER

Sl No.	Category of Animal	Paddock (Open Area) m <sup>2</sup>	Shelter (Covered Area) m <sup>2</sup>	Maximum Number of Animals to be Kept in Each Shelter
i)	Buffalo	8	4	40
ii)	Cow	7	3.5	40
iii)	Young stock	4	2	30
iv)	Calf	2	1	30
v)	Calving pen	12	12	1
vi)	Bull	26	12	1

**8.7.1 Manger and water trough** — Manger and water trough may be constructed in paddocks with reinforced cement concrete, brick with cement mortar or stone slabs with cement joining. A 2 m wide paved platform shall be provided away from trough to withstand the heavy treading of animals and permit easy washing and cleanliness.

**8.8 Fencing** — It shall be in accordance with 8.2 of IS : 11799-1986.

**8.9 Gate** — A gate of suitable type and size may be provided taking care that they are hinged firmly and raised well above the ground. Braces shall be positioned vertically.

### 9. Ancillary Structures

**9.1 Milk House** — Milk collection, recording, testing and cooling facilities as well as facilities for cleaning and stacking of milking pails and milk cans have to be provided in this house. This floor space can accommodate the milk recording equipment, milk cooling device in the form of bulk cooler, can racks, milking pail rack, sinks, washing outfit and furniture of the milk recorder. On very large farms, the different components of the milk house, that is recording-cum-milk cooling room, milk utensils and equipment room and washing room, may be constructed as separate units. The doors and the windows of the milk house shall be made fly-proof. The flooring of the room shall be of cement concrete, impervious and reinforced with iron strips located at suitable distances to make it hard wearing. The walls should be lined with white glazed tiles up to a height of 1.5 m. A suitable platform or concrete slab in the form of bench shall be provided for keeping the milk testing apparatus.

**IS : 12237 - 1987**

**9.2 Stores** — There shall be one main concentrate store-cum-feed mixing room at a distant place but it is advisable to have a small ration room near the milking barn for storing prepared concentrate mixture temporarily for a day or two. On smaller farms, one feed store near the milking barn would be sufficient. The feed room shall be damp-proof and rodent-proof.

**9.3 Silo** — Suitable size trench silo may be provided.

**9.4 Hay/Straw Shed** — Shed, preferably with walls on three sides may be provided for storing straw or hay. Storing hay or straw as stacks in the open results in excessive wastage in the form of spoilage and deterioration. Sometimes, a simple shed with gabled roof is used. The hay shed shall be away from animal sheds because of fire hazards. On larger farms, the hay sheds can be made into a sort of self-feeding hay bunks by placing movable wooden partition on one side edge of the hay shed so that the animals can eat hay at will from only the portions accessible through this wooden partition and do not spoil the hay excessively.

**9.5 Chaffing Shed** — A shed for chaffing the fodder with chaffing machine or ensilage cutter is erected. The shed may have provisions for power supply to the machine.

**9.6 Office Room** — Depending upon the size of the farm, an office room may be provided. The office room may also be used for keeping medicines and instruments required for treating sick animals. A toilet may also be provided. A visitors' room may be attached to the office room.

**9.7 Trevis or Cattle Crutch** — A cattle trevis may be provided in the general utility area for securing animals for insemination, treatment, etc.

**9.8 Segregation Room** — Provision may be made for a segregation room for keeping new animals introduced in the herd for some initial days before their mixing up with the herd.

**9.9 Lighting** — Provision of lighting shall be made; in case electricity is available, a 25 W bulb for each 10 m<sup>2</sup> space or 60 W bulb for each 20 m<sup>2</sup> space or equivalent tube light may be provided.

**9.10 Biogas Plant** — A bio-gas plant of suitable size may be installed so that the farm wastes (biomass) can be used to produce gas for use on the farm.

**EXPLANATORY NOTE**

Animal housing helps in moderating the range of microenvironment to which the animals are exposed and optimizes their production by protecting them from extreme climates. Normally, the animal housing consists of either barn system or loose system.

This standard covers the details of loose housing which is becoming now more popular. A number of Indian Standards on barn system of housing have already been published.

In the preparation of this standard, assistance has been derived from the Department of Live-stock Production and Management, Haryana Agricultural University, Hissar.

IS 11799 : 2005

भारतीय मानक  
ग्रामीण क्षेत्रों में पशु-आवास के लिए अनुशंसाएँ  
( पहला पुनरीक्षण )

*Indian Standard*  
RECOMMENDATIONS FOR CATTLE HOUSING IN  
RURAL AREAS  
( *First Revision* )

ICS 65.040.10

© BIS 2005

**BUREAU OF INDIAN STANDARDS**  
MANAK BHAVAN, 9 BAHADUR SHAH ZAFAR MARG  
NEW DELHI 110002

May 2005

Price Group 5

## FOREWORD

This Indian Standard (First Revision) was adopted by the Bureau of Indian Standards, after the draft finalized by the Livestock Feeds, Equipment and System Sectional Committee had been approved by the Food and Agriculture Division Council.

Proper housing is an important feature in raising the production capabilities of animals, in addition to good breeding, feeding, selection and disease control. It is conducive to good health, comfort protection from inclement weather and the animals are capable of utilizing their genetic abilities and feed for optimum production.

Cattle raising and dairying is practiced in the country by various interests. Generally these interests are : (a) an average farmer who has not more than a pair of bullocks and two or three milch animals with their calves; (b) a rural milk producer normally having a total of about 20 animals including about 12 milch animals, their followers and a pair of bullocks; (c) *GAUSHALAS* and other organized milk producers; and (d) large dairy farms.

This standard was published in 1986, covering recommendations for cattle housing for rural milk producer. This revision has been taken up to enlarge the scope of the standard by incorporating the recommendations for cattle housing for an average farmer (IS 11786:1986 'Recommendations for cattle housing for an average farmer') and updating the referred standard.

For the purpose of deciding whether a particular requirement of this standard is complied with, the final value, observed or calculated, expressing the result of a test or analysis, shall be rounded off in accordance with IS 2 : 1960 'Rules for rounding off numerical values (*revised*)'. The number of significant places retained in the rounded off value should be the same as that of the specified value in this standard.

*Indian Standard*  
**RECOMMENDATIONS FOR CATTLE HOUSING IN  
 RURAL AREAS**  
*(First Revision)*

**1 SCOPE**

This standard covers recommendations for layout and constructional details of a cattle shed meant for an average farmer normally having three milch animals with their calves and a pair of bullock and rural milk producer normally having 20 animals which may include about 12 milch animals, their followers and a pair of bullocks.

**2 REFERENCES**

The following standards contain provisions which through reference in this text, constitute provisions of this standard. At the time of publication, the editions indicated were valid. All standards are subject to revision and parties to agreements based on this standard are encouraged to investigate the possibility of applying the most recent editions of the standards indicated below:

<i>IS No.</i>	<i>Title</i>
258 : 2000	Potash alum --- Specification <i>(second revision)</i>
712 : 1984	Specification for building limes <i>(third revision)</i>
797 : 1982	Common salt for chemical industries <i>(third revision)</i>
3583 : 1988	Specification for burnt clay paving bricks <i>(second revision)</i>
3622 : 1977	Specification for sand stone (slabs and tiles) <i>(first revision)</i>

**3 TERMINOLOGY**

For the purpose of this standard, the following definitions shall apply.

**3.1 Paddock or Yard** — An open area surrounded by walls, fences or rails for accommodating cattle. This area is meant to provide open air exercise to the animals. It generally contains manger(s) or trough(s) with or without ties to control animals for different purpose.

**3.2 Standard (Stall)** — The floor space provided within a shed for an individual animal to stand or lie.

**4 SELECTION OF SITE**

**4.1** The shed shall be located on dry, elevated and well-drained area with consideration for future expansion.

**4.2** The shed shall preferably be located at a place where there are enough suitably placed trees to serve as wind-breaks and to provide shade. In order to break the wind, it is recommended that a row of trees be also planted across the directions of wind at the boundary of the farm.

**4.3** The site shall be away from public road but easily accessible throughout the year.

**4.4** The site shall be such that arrangement could be made for adequate and good water supply.

**4.5** The site shall be such that the long axis of the shed could be oriented east to west in all areas except temperate Himalayan and hilly regions. In desert areas, the shed shall be oriented across the prevailing direction of the wind in order to protect the roof from being blown off by high wind.

**4.5.1** In coastal areas the shed shall be oriented along the prevailing wind direction in order to protect the roof from being blown off by high wind and at the same time to provide sufficient air movement in the shed. In sub-mountainous region, the buildings should be so sited as to avail of the natural aeration and drying.

**5 HERD SIZE**

A typical herd for an average farmer has been assumed to have about 5 animals comprising 3 milch animals, their followers and a pair of bullocks whereas for rural milk producer it is about 20 animals comprising 12 milch animals of which about 8 may be in milk. The remaining eight animals may include the followers of adult animals and a pair of bullocks.

**6 SHED AND LAYOUT****6.1 For an Average Farmer**

An average farmer having not more than three milch animals with calves and a pair of bullocks generally makes use of an existing wall for constructing the cattle shed. The construction of shed under this interest, therefore, has been suggested assuming that a lean to type roof could be built against an existing wall. Arrangement of adequate water supply and light shall be made in the shed. The typical layout of such a shed to accommodate five animals is shown in Fig. 1. The two side walls should be of height not more than

1.2 m. The height of main wall (see A in Fig.1) shall be minimum of 2.5 m.

#### 6.2 For a Rural Milk Producer

The shed shall consist of standings for accommodating adult animals and the young stock. At the far end of the shed, there shall be a room for accommodating calves and a separate calving box. The paddock or yard for adult and young stock and calves may be separate on either side of the standings. The calves and the down calver shall have separate paddocks or yards for themselves laid adjacent to the calf room and calving box.

6.2.1 The layout and overall dimensions of each of the units (see 6.2) may be as given in Fig. 2 and Fig. 3.

### 7 CONSTRUCTION

#### 7.1 Standing

For an average farmer the standings shall be constructed in such a way that the animals are kept facing towards the wall. The manger shall be adjacent to the wall. The length, width and area of cow shed and buffalo shed capable of accommodating one to four cattle is given in Table 1.

For a rural milk producer the standings shall be constructed in such a way that the animals are arranged in rows. The length and width of each standing shall be decided depending upon the size of the animals. The length and width of each standing shall be decided depending upon the size of the animals. The length and width of each standing may vary from 1.5 m to 1.7 m and 1.0 m to 1.2 m per animal respectively. In coastal region, sometimes buffaloes with spreading horns are found; in that case the width per animal may vary from 1.2 m to 1.3 m.

##### 7.1.1 Floor of Standings

The floor may be either of MOORUM KANKAR and

sand, cement concrete, stone slabs or bricks-on-edge. The details of laying these floorings may be as given in Annex A. A plinth of at least 15 cm shall be provided for the floor. The surface of the cement concrete or stone flooring shall be grooved to make it non-slippery for animals. For larger animals, the grooves shall be formed in a square of 15 cm × 15 cm and for calves 10 cm × 10 cm (see A in Fig. 4). The width of the groove shall be 12 mm and depth 10 mm. The groove shall be of 'U' shape. A slope of 1 in 60 towards the drain shall be provided in order to keep the floor properly drained after washing. Steel rings may be provided on the floor near the manger for tying the animals.

#### 7.1.2 Manger

The manger shall be continuous type. The manger shall be made of stone slabs, wooden plank or brick-in-line or cement mortar. The flooring material of the manger shall be the same as for the floor but the surface shall be finished smooth. All the corners of the manger shall be rounded off and finished smooth. The dimensions of the manger (see Fig. 5) shall be as given in Table 2. In case the mangers are of brick, the fore curb should be topped with angle iron.

#### 7.2 Walls

The wall shall be of brick or stone slab laid in cement mortar. The wall may be cement-plastered from inside. The thickness of the wall shall be at least 20 cm. All walls shall be solid up to 1.25 m height from the floor level and shall be constructed in honey comb pattern above that height in order to provide sufficient air movement in the shed. The rest of the portion of the wall may be left open by a series of wire-netted windows. In desert areas, the solid portion may extend up to 1.8 m in height. In case of lean-to type system, the end walls above the solid portion may be left open or provided with a series of wire-netted windows.

Table 1 Space Norms for Cattle Shed

(Clause 7.1)

All dimensions in metres.

No. of Cattle	Cow Shed		Buffalo Shed		Remarks
	Length	Width	Length	Width	
(1)	(2)	(3)	(4)	(5)	(6)
1	2.5	3.0	2.7	3.4	Along with calf
2	4.2	3.0	5.2	3.4	Along with calves
3	5.7	3.0	7.3	3.4	Along with calves
4	5.6 2.0	3.0 1.5	6.8 2.4	3.4 1.9	For cattle For calves

### 7.3 Pillars

One pillar shall be placed at intervals of every two or three standings depending on the width of each standing. Pillars may be made from any of the following materials and their minimum dimensions shall be as indicated against each:

- |                         |   |
|-------------------------|---|
| a) Brick                | 45 cm × 35 cm<br>(see Note 1) or<br>40 cm × 30 cm<br>(see Note 2) |
| b) Mild steel I section | 10 cm × 10 cm   |
| c) Stone masonry        | 30 cm × 30 cm   |
| d) Iron pipes, dia      | 10 cm   |
| e) Timber               |   |
| 1) Square               | 10 cm × 10 cm   |
| 2) Round                | 15 cm dia   |

#### NOTES

- In case of 22.5 cm × 11.25 cm brick, 2 lengths and 3 widths shall be used.
- In case of 20 cm × 10 cm (modular) brick, 2 lengths and 3 widths shall be used.
- All iron structures shall be suitably painted for protection against corrosion.

7.3.1 All edges in rectangular pillars shall be rounded off a finished smooth.

### 7.4 Roof

The roof shall be of lean-to type or gabled type. The roof material may either be asbestos cement sheets, galvanized steel sheets, asphalt roofing material, or locally available material. Where necessary, particularly in hot climate, asbestos cement or galvanized steel roofs may be overlaid with a 8 cm to 10 cm thick thatch to lessen the stress of extreme climate. In areas where locally available materials are used, gunny sacks treated with cement lime mixture (see 7.4.1) may be used. The roof shall be supported by steel or wooden trusses or by a series of central pillars. The pitch of the roof may range from 22 to 30 degrees depending upon the material used. Wooden purlins may be spaced up to 1.3 m apart. The eaves of the roof shall project out (see A in Fig. 2 and 3) at least 50 cm away from the pillars and in the regions where extreme climatic conditions prevail, the eaves of the roof may project out to 75 cm from the pillars in order to afford protection to the animals from direct sun and rain. The eaves should be 2.2 mm high from ground level (see B in Fig. 2 and 3).

#### 7.4.1 Preparation of Cement Lime Mixture

Stir thoroughly 12 parts by volume of cement and three parts by volume of lime (see IS 712) salt (see IS 797) and one-half part by volume of alum (see IS 258) and stir until all ingredients are well mixed. Apply the mixture evenly with the help of a brush on the inner surface of the gunny sack. Give

Table 2 Dimensions of Manger

(Clause 7.1.2)

All dimensions in centimetres.

Sl.No.	Particulars	Stone Slab	Wooden Plank	Brick Laid in Cement or Lime	Ref to Fig. 1
(1)	(2)	(3)	(4)	(5)	(6)
i)	Height of the manger wall, <i>Min</i>	75	75	75	A
ii)	Height of fore curb, <i>Max</i>				
a)	For adults	50	50	50	B
b)	For calves	30	30	30	B
iii)	Thickness of fore curb, <i>Min</i>	4	3	10	C
iv)	Inner width of the manger, <i>Min</i>				
a)	For adults:				
1)	One way feeding	60	60	60	D
2)	Two way feeding	120	120	120	D
b)	For calves: one way feeding	40	40	40	D
v)	Depth of manger, <i>Min</i> :				
a)	For adults	40	40	40	E
b)	For calves	15	15	15	E

two coats of the mixture on the outer surface of the gunny sack. Stretch the gunny sack and dry in the sun until it becomes stiff.

#### 7.5 Drains

The drain shall be laid in the shed at the back of the standing. In case of gabled type roof, two drains shall be laid outside the shed, one on each side of the standing. The drain shall be made of brick in cement mortar or of stone and shall be of 'U' shape with a depth of 6 cm at the bottom. The slope of the drain shall be 1 in 40 to 1 in 60. The width of the drain (see C in Fig. 2 and 3) may vary between 30 cm and 40 cm. The drain may be led to a common urine pit having a depth not exceeding 40 cm or to the field if slope permits. The urine pit may be circular or rectangular.

#### 7.6 Special Constructional Requirements for a Rural Milk Producer

##### 7.6.1 Water Supply

There shall be an adequate supply of potable water in the shed. For this purpose, a trough of reinforced cement concrete or brick-in-cement should be provided. The size of the trough shall depend upon the daily requirement of water calculated at the rate of 50 litres per livestock per day. The water troughs should be provided with railing on its sides so that the animals may not try to step in the water trough and contaminate it.

##### 7.6.2 Calf-Room

A part of the standing at the far end of the shed shall be partitioned suitably for housing calves. Generally, a floor space of 1.2 m<sup>2</sup> to 1.5 m<sup>2</sup> is recommended per calf. There shall be a manger adjacent to the wall of the room. A wall covering half the height of the room shall be provided in order to separate the calf-room from its adjoining yard.

##### 7.6.3 Calving-Box

A separate unit shall be provided for housing one

down-calver. The calving-box shall be adjacent to the calf-room and at the end of the standings. The box shall be separated from the calf-room as well as from the rest of the shed by a suitable partition. The dimensions of the calving-box shall be 2.8 m × 4 m. There shall be cement concrete manger and water trough in one corner of the box. The width of the manger and the water trough shall be at least 60 cm.

#### 8 OTHER REQUIREMENTS FOR A RURAL MILK PRODUCER

##### 8.1 Paddock or Yard

8.1.1 The design of the paddock or open yard may be made while using the common wall of the residence of the average farmer. There shall be a paddock with the following minimum space per animal for various categories of animals:

a) Buffalo	8 m <sup>2</sup>
b) Cow	7 m <sup>2</sup>
c) Young stock	4 m <sup>2</sup>
d) Calf	2 m <sup>2</sup>
e) Calving	12 m <sup>2</sup>

8.1.2 There shall be feeding and water troughs within the paddock.

##### 8.2 Fencing

8.2.1 The wall of bricks or stone slabs or a railing or wires may constitute fence. The railings may be of 35 mm galvanized iron pipe or 5 mm galvanized iron wire and posts to support railings. The posts may be of 5 cm steel pipe, 6 cm × 4 cm angle iron, 8 cm × 5 cm stone slabs or 10 cm × 10 cm timber placed 2 m apart. The posts shall be holed to pass the railings through or it may be riveted or 'U' bolted to the place.

8.2.1.1 The railings for different categories of the animals shall be fixed with the posts as given below:

Height from Ground to Centre of Each Rail	Calves cm	Cows, Young Stock and Buffaloes cm	Bull cm
First rail	30	40	40
Second rail	60	80	80
Third rail	90	120	120
Fourth rail	120	—	150



8.2.2 The wooden horizontal braces or steel horizontal braces shall be placed as given in Fig. 6. Braced steel end or corner posts shall be embedded as given in Fig. 7.

8.3 Ancillary Structure

8.3.1 Provision of milk recording room and ration room, each of approximately 9 m<sup>2</sup>, preferably at fore end of the shed, may be made.

9 LIGHTING

Provision of lighting shall be made. In case electricity

is available, 125 W bulb for each 10 m<sup>2</sup> floor space or 60 W bulb for each 25 m<sup>2</sup> space or equivalent fluorescent tube light may be provided.

10 WASTE HANDLING

It is suggested that bio-gas plant of suitable size should be installed. The animal waste should be removed from standing/dung alley either by scrapping or direct collection in hand push cart or animal cart and taken to feed the bio-gas plant.

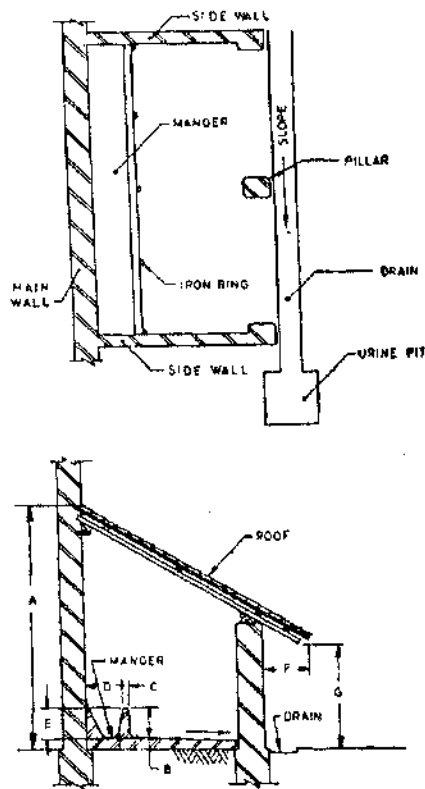

FIG. 1 TYPICAL LAYOUT OF FARM CATTLE SHED

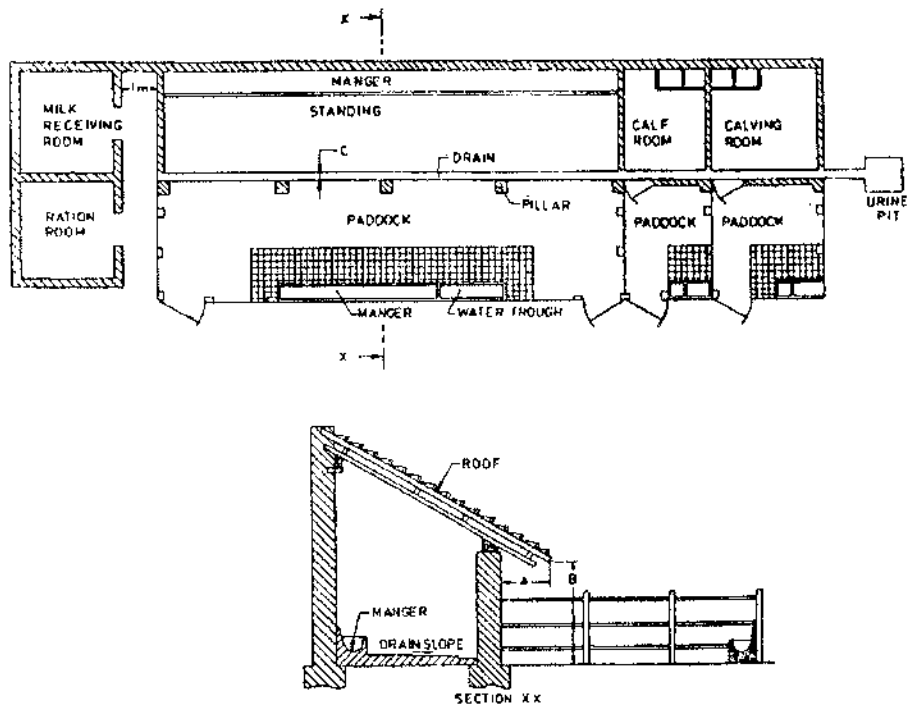

FIG. 2 A TYPICAL LAYOUT OF SHED, LEAN-TO TYPE ROOF

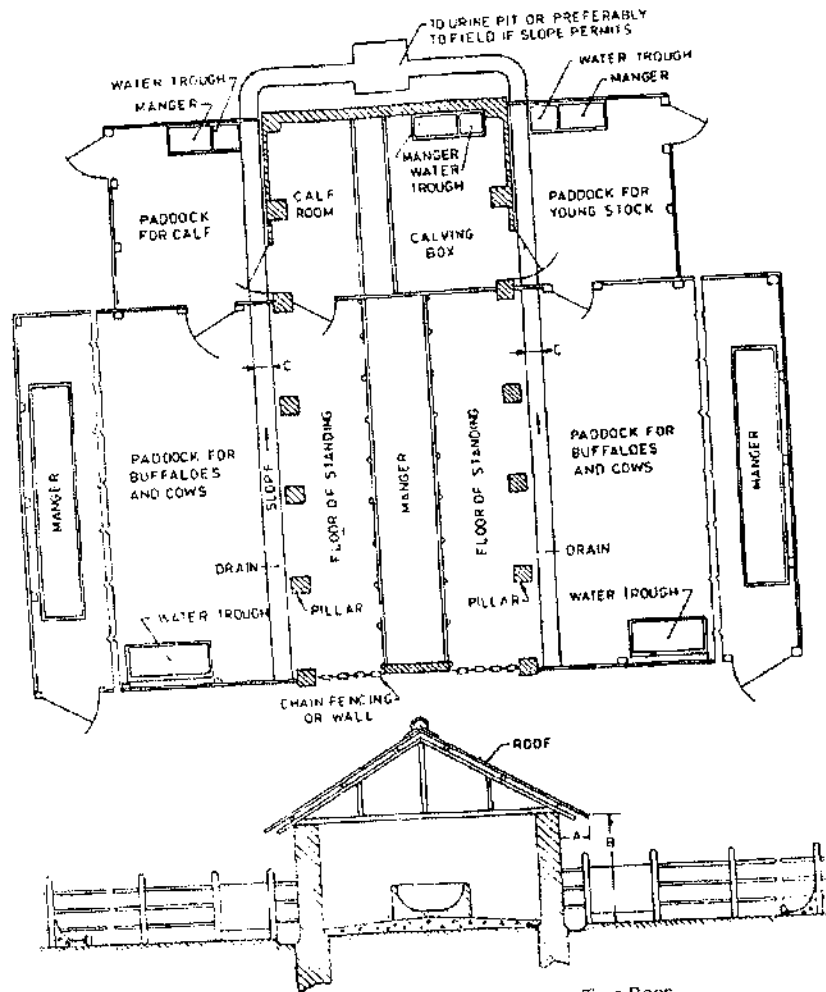
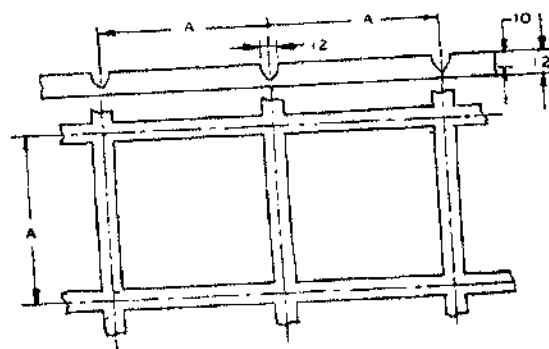
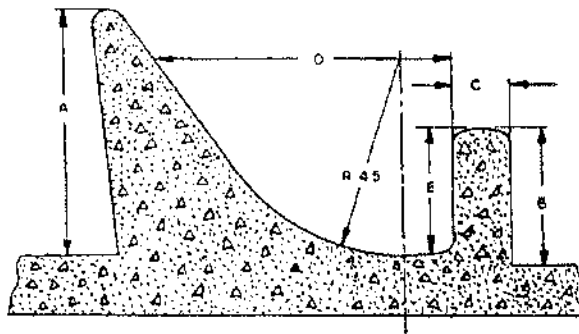

FIG. 3 A TYPICAL LAYOUT OF SHED, GABLED TYPE ROOF



All dimensions in millimetres.  
FIG. 4 CROSS-SECTION OF STANDING



All dimensions in millimetres.

FIG. 5 CROSS-SECTION OF MANGER

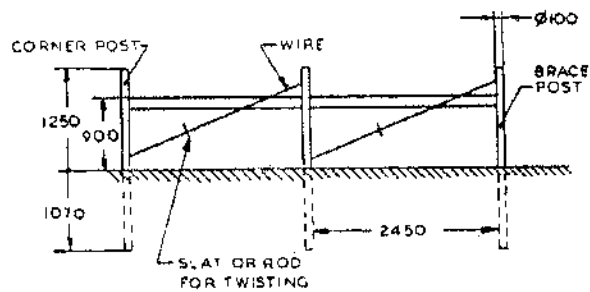

All dimensions in millimetres.

FIG. 6 WOOD OR STEEL HORIZONTAL BRACES

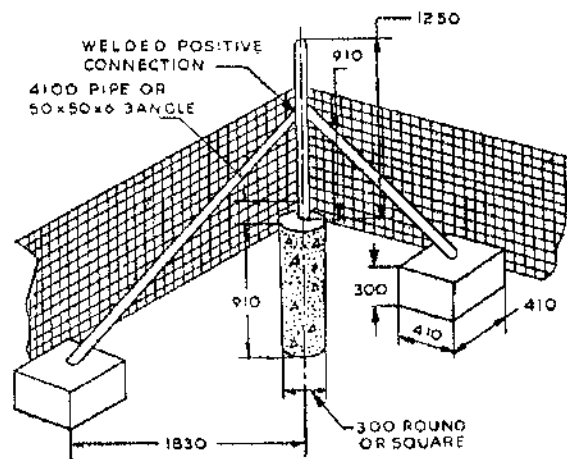

All dimensions in millimetres

FIG. 7 BRACED STEEL END OR CORNER POST

## ANNEX A

(Clause 7.1.1)

## DETAILS OF LAYING DIFFERENT TYPES OF FLOORING OF STANDINGS

**A-1 MOORUM, KANKAR AND SAND FLOORING**

The *moorum*, *kankar* and sand flooring shall be laid over a subgrade or rubble packing or broken bricks of 15 to 25 cm thick wetted and well rammed. A 1.5 cm layer of hard *moorum*, *kankar* and sand (as the case may be) shall be laid over this subgrade with coarser pieces at the bottom and fine ones over at the top. A layer of powder *moorum*, *kankar* and sand about 3 to 5 cm shall be spread over the top of this layer. Water shall then be sprinkled and the surface shall be well rammed. Water shall again be sprinkled until the floor is fully saturated. The surface shall be rammed, leveled and well consolidated. When the floor is dry, a thick paste of cow dung plaster shall be uniformly spread and it shall be well rammed. A final thin coating of mixture of cow dung (four parts) and cement (one part) shall be applied after the floor has dried up and wiped clean to prevent cracking and puccelling. The cow dung plaster shall be applied weekly or fortnightly to keep the floor in good condition.

**A-2 BRICK ON EDGE FLOORING**

**A-2.1** The subgrade for this type of flooring shall be rubble or brick aggregates which shall be hand packed, watered and well rammed. A layer of 10 cm of lime concrete shall be spread over the subbase, well rammed and shall be allowed to set for 7 days. The bricks shall be well burnt and of good quality (see IS 3583) and shall be well soaked in water before laying. Bricks shall be laid on about 10 mm thick cement or lime mortar bed and each brick shall be properly bedded on edge and set home by gentle tapping with the handle of trowel or a wooden mallet. Its inside faces shall be buttered with mortar before the next brick is laid and pressed against it. On completion of a portion of flooring the vertical joints shall be fully filled from the top with the mortar.

**A-2.2** The surface of the flooring during the laying shall be frequently checked with a straight edge at

least 2 m long so as to obtain a true surface with the required slope. The surface of the flooring shall be kept constantly moist for a minimum period of 7 days. In the case of fat lime mortar, curing shall commence two days after the laying of the flooring and shall continue for 7 days. The bricks may be laid in rows having the joints parallel and at right angles to the walls or in 'herringbone' pattern.

**A-3 STONE SLAB FLOORING**

**A-3.1** The stone slabs shall be of good quality, hard, sound and dense (see IS 3622). Apart from sandstone any other good quality stone slabs may be used according to the availability of the material. The subgrade shall be prepared as given in A-2.1 and the lime concrete bed shall be cleaned, wetted and mopped. The bedding for the slabs shall be made with cement mortar 1:4 (1 cement : 4 coarse sand) or with lime mortar (either 1 lime putty : 1 surkhi : 1 coarse sand or 1 lime putty : 2 coarse sand). The average thickness of the bedding mortar under the slab shall be 20 mm. The mortar shall be spread under the area of each slab to the specified thickness. The stone slab shall be washed clean before laying. It shall be laid on top, pressed, tapped with wooden mallet and brought to level with the adjoining slabs. It shall be lifted and laid aside. The top surface of the mortar shall then be corrected by adding fresh mortar at hollows. The edges of the slab already paved shall be buttered with cement slurry. The slab to be paved shall be lowered gently back in position and tapped with wooden mallet till it is properly bedded in level with and close to the adjoining slab with as fine joints as possible. Subsequent slabs shall be laid in the same manner. After each slab has been laid, surplus cement on the surface of the slab shall be cleaned off. The flooring shall be cured for a minimum period of 7 days. The surface of the flooring as laid shall be true to a level and shall be of the desired slope. Slight unevenness at the meeting edges of slabs shall be removed by fine chiseling.

### Bureau of Indian Standards

BIS is a statutory institution established under the *Bureau of Indian Standards Act, 1986* to promote harmonious development of the activities of standardization, marking and quality certification of goods and attending to connected matters in the country.

### Copyright

BIS has the copyright of all its publications. No part of these publications may be reproduced in any form without the prior permission in writing of BIS. This does not preclude the free use, in the course of implementing the standard, of necessary details, such as symbols and sizes, type or grade designations. Enquiries relating to copyright be addressed to the Director (Publications), BIS.

### Review of Indian Standards

Amendments are issued to standards as the need arises on the basis of comments. Standards are also reviewed periodically; a standard along with amendments is reaffirmed when such review indicates that no changes are needed; if the review indicates that changes are needed, it is taken up for revision. Users of Indian Standards should ascertain that they are in possession of the latest amendments or edition by referring to the latest issue of 'BIS Catalogue' and 'Standards: Monthly Additions'.

This Indian Standard has been developed from Doc. No. FAD 5 (1533).

### Amendments Issued Since Publication

Amend No.	Date of Issue	Text Affected

### BUREAU OF INDIAN STANDARDS

#### Headquarters:

Manak Bhavan, 9 Bahadur Shah Zafar Marg, New Delhi 110002

Telephones: 2323 0131, 2323 3375, 2323 9402

website : [www.bis.org.in](http://www.bis.org.in)

#### Regional Offices:

#### Telephones

Central	: Manak Bhavan, 9 Bahadur Shah Zafar Marg NEW DELHI 110002	{ 2323 7617 2323 3841
Eastern	: 1/14 C.I.T. Scheme VII M, V.I.P. Road, Kankurgachi KOLKATA 700054	{ 2337 8499, 2337 8561 2337 8626, 2337 9120
Northern	: SCO 335-336, Sector 34-A, CHANDIGARH 160022	{ 260 3843 260 9285
Southern	: C.I.T. Campus, IV Cross Road, CHENNAI 600113	{ 2254 1216, 2254 1442 2254 2519, 2254 2315
Western	: Manakalaya, E9 MIDC, Marol, Andheri (East) MUMBAI 400093	{ 2832 9295, 2832 7858 2832 7891, 2832 7892
Branches	: AHMEDABAD, BANGALORE, BHOPAL, BHUBANESHWAR, COIMBATORE, FARIDABAD, GHAZIABAD, GUWAHATI, HYDRABAD, JAIPUR, KANPUR, LUCKNOW, NAGPUR, NALAGARH, PATNA, PUNE, RAJKOT, THIRUVANANTHAPURAM, VISAKHAPATNAM.	

Printed at Simco Printing Press, Delhi

IS : 11942 - 1986

[ Superseding IS : 4466 ( Part 3 )-1968,  
IS : 5605 ( Part 3 )-1970 and  
IS : 8845 ( Part 3 )-1970 ]

*Indian Standard*

RECOMMENDATIONS FOR  
GAUSHALA AND OTHER ORGANIZED  
MILK PRODUCERS

UDC 631.223.24 : 725.42

© Copyright 1987

**BUREAU OF INDIAN STANDARDS**  
MANAK BHAVAN, 9 BAHADUR SHAH ZAFAR MARG  
NEW DELHI 110002

Gr 5

July 1987

IS : 11942 - 1986

[ Superseding IS : 4466 ( Part 3 )-1968,  
IS : 5605 ( Part 3 )-1970 and  
IS : 8845 ( Part 3 )-1978 ]

*Indian Standard*  
**RECOMMENDATIONS FOR  
GAUSHALA AND OTHER ORGANIZED  
MILK PRODUCERS**

Animal Structures and Equipment Sectional Committee, AFDC 17

<i>Chairman</i>	<i>Representing</i>
PROF A. P. BHATNAGAR	Punjab Agricultural University, Ludhiana
<i>Members</i>	
DR C. L. ABORA	Indian Council of Agricultural Research, New Delhi
MAJ-GEN R. K. R. BALASUBRA- NANTAN	Directorate of Remount Veterinary Services, New Delhi
LT-COL K. VENKATARAMAN ( <i>Alternate</i> )	
DR A. K. BASUTHAKUR	Ministry of Agriculture & Rural Development ( Department of Agriculture & Co-operation ), New Delhi
DR IQBALUDDIN ( <i>Alternate</i> )	
DR D. S. BHANDARI	Directorate of Animal Husbandry, Government of Rajasthan, Jaipur
DR G. K. RASTOGI ( <i>Alternate I</i> )	
DR P. S. CHAUDHARY ( <i>Alternate II</i> )	
DR P. N. BHAT	Indian Veterinary Research Institute ( ICAR ), Izatnagar
DR V. K. TANEJA ( <i>Alternate</i> )	
DR J. L. BHUTANI	Milk Commissioner, Government of Haryana, Chandigarh
DR P. K. GHOSH	Central Arid Zone Research Institute ( ICAR ), Jodhpur
DR R. S. GREWAL	Directorate of Animal Husbandry, Government of Punjab, Chandigarh
DR N. S. UPPAL ( <i>Alternate</i> )	
SHRI H. GUHA	Directorate of Animal Husbandry, Government of West Bengal, Calcutta
SHRI S. GUPTA ( <i>Alternate</i> )	
DR GURCHARAN SINGH	Indian Agricultural Research Institute ( ICAR ), New Delhi
SHRI GURDIP SINGH	Hi-Bred ( India ) Pvt Ltd, Karnal
SHRI HAIDER ALI KHAN ( <i>Alternate</i> )	

( Continued on page 2 )

© Copyright 1987

BUREAU OF INDIAN STANDARDS

This publication is protected under the *Indian Copyright Act* ( XIV of 1957 ) and  
reproduction in whole or in part by any means except with written permission of the  
publisher shall be deemed to be an infringement of copyright under the said Act.



IS : 11942 - 1986

(Continued from page I)

Members	Representing
DR K. HANUMANTHA RAO	Directorate of Animal Husbandry, Government of Andhra Pradesh, Hyderabad
DR VINWA RAJ (Alternate)	Central Sheep and Wool Research Institute (ICAR) Jaipur
DR MANOHAR SINGH	Central Sheep and Wool Research Institute (ICAR) Jaipur
DR S. K. KAUSHISH (Alternate)	The Bharatiya Agro-Industries Foundation, Pune
DR M. R. MARATHI	The Bharatiya Agro-Industries Foundation, Pune
DR D. V. RANGNEKAR (Alternate)	Central Avian Research Institute, Izatnagar
DR S. C. MOHAPATRA	Central Avian Research Institute, Izatnagar
DR S. D. ADEJA (Alternate)	Central Institute for Research on Buffaloes (ICAR), Hissar
SHRI V. D. MUDGAL	Central Institute for Research on Buffaloes (ICAR), Hissar
SHRI S. K. JINDAL (Alternate)	Indian Dairy Corporation, Vadodara
DR (KUMARI) A. PATEL	Indian Dairy Corporation, Vadodara
DR S. N. SINGH (Alternate)	National Dairy Research Institute (ICAR), Karnal
DR M. V. N. RAO	National Dairy Research Institute (ICAR), Karnal
DR S. R. SAMPATH (Alternate)	Andhra Pradesh Agricultural University, Hyderabad
DR P. V. RAO	Andhra Pradesh Agricultural University, Hyderabad
DR P. VARADARAJULU (Alternate)	Directorate of Military Farms, Army Headquarters, QMG's Branch, New Delhi
LT COL S. K. ROY	Directorate of Military Farms, Army Headquarters, QMG's Branch, New Delhi
SHRI SHAHID ALI (Alternate)	Haryana Agricultural University, Hissar
DR N. S. R. SASTRY	Directorate of Animal Husbandry, Haryana
DR S. N. SHARMA	Directorate of Animal Husbandry, Haryana
DR H. L. ABHI (Alternate)	Central Institute of Agricultural Engineering (ICAR), Bhopal
DR B. D. SHUKLA	Central Institute of Agricultural Engineering (ICAR), Bhopal
SHRI P. K. SRIVASTAV (Alternate)	ICAR Research Complex for N. E. H. Region, Shillong
SHRI M. D. SINGH	ICAR Research Complex for N. E. H. Region, Shillong
SHRI A. SINGH (Alternate)	Kerala Agricultural University, Trichur
DR M. SUBRAHMANYAN	Director General, BIS (Ex-officio Member)
SHRI T. PURNANANDAM, Director (Agri & Food)	Director General, BIS (Ex-officio Member)

Secretary

SHRI R. N. SHARMA  
Joint Director (Agri & Food), BIS

**AMENDMENT NO. 1 DECEMBER 2005**  
**TO**  
**IS 11942 : 1986 RECOMMENDATIONS FOR GAUSHALA**  
**AND OTHER ORGANIZED MILK PRODUCERS**

*( Page 16, clause 10.8 )* — Substitute the following for the existing text:

'Provision must be made for a suitable foot bath at the entrance gate. Also at the main entrance of the gate, a concrete floor should be constructed. This is to ensure that any vehicle entering the farm will be allowed to pass through the shallow floor which contains medicated solution.'

( FAD 5 )

---

Reprography Unit, BIS, New Delhi, India

*Indian Standard*  
**RECOMMENDATIONS FOR  
 GAUSHALA AND OTHER ORGANIZED  
 MILK PRODUCERS**

**0. FOREWORD**

**0.1** This Indian Standard was adopted by the Indian Standards Institution on 31 December 1986, after the draft finalized by the Animal Structures and Equipment Sectional Committee had been approved by the Agricultural and Food Products Division Council.

**0.2** Proper housing is an important feature in raising the production capabilities of animals, in addition to good breeding, feeding, selection and disease control. It is conducive to good health, comfort and protection from inclement weather and the animals are capable of utilizing their genetic abilities and feed for optimum production.

**0.3** Cattle raising and dairying is practised in the country by various interests. Generally these interests are: (a) an Average Farmer who has not more than a pair of bullocks and two or three milch animals with their calves; (b) rural Milk Producers normally having a total of about 20 animals including about 12 milch animals, their followers and a pair of bullocks; (c) *gaushalas* and other organized milk producers; and (d) Large Dairy Farms.

**0.4** This standard covers recommendations for shed for *GAUSHALA* and other organized milk producers. It supersedes IS : 4466 ( Part 3 )-1968\*, IS : 5605 ( Part 3 )-1970†, and IS : 8845 ( Part 3 )-1978‡. Since India's climatic conditions, unlike most of the principal dairy countries of the world, are very varied, hence shed of cattle would also vary according to the climatic conditions prevailing in a particular region. In order to meet these varied requirements, wherever necessary specific recommendation has been made for (a) plain areas with medium rainfall, (b) arid area, (c) high altitude areas, and (d) heavy rainfall and high humidity areas.

\*Recommendations for farm cattle housing for plain areas with medium rainfall: Part 3 Farm cattle sheds for *GAUSHALAS* and other organized milk producers.

†Recommendations for farm cattle housing for heavy rainfall and high humidity areas: Part 3 Farm cattle sheds for *GAUSHALAS* and other organized milk producers.

‡Recommendations for farm cattle housing for arid areas: Part 3 Farm cattle sheds for *GAUSHALAS* and other organized milk producers.

IS : 11942 - 1986

## 1. SCOPE

1.1 This standard recommends layout and constructional details of a cattle shed meant for *GAUSHALA* and other organized milk producer.

## 2. TERMINOLOGY

2.1 For the purpose of this standard, the following definitions shall apply.

2.1 **Paddock or Yard** — An open area surrounded by walls, fences or rails for accommodating cattle. This area is meant to provide open air exercise to the animals. It generally contains manager(s) or trough(s) with or without ties to control animals for different purposes.

2.2 **Standing ( Stall )** — The floor space provided within a shed for an individual animal to stand or lie.

## 3. SELECTION OF SITE

3.1 The shed shall be located on dry, elevated and well-drained area with consideration for future expansion.

3.2 The shed shall preferably be located at a place where there are enough suitably placed trees to serve as wind-breaks and to provide shade. In order to break the wind it is recommended that a row of trees be also planted across the direction of wind at the boundary of the farm.

Note — In case there are no shaded trees on the site, these should be planted immediately keeping a minimum distance of 4 m from the shed.

3.3 The site shall be away from public road but easily accessible throughout the year.

3.4 The site shall be such that arrangement could be made for adequate and good water supply.

3.5 The site shall be such that the long axis of the shed could be oriented east to west in all areas except temperate Himalayan and hilly regions. In desert areas, the shed shall be oriented across the prevailing direction of the wind in order to protect the roof from being blown off by high wind.

3.5.1 In coastal areas the shed shall be oriented along the prevailing wind direction in order to protect the roof from being blown off by high wind and at the same time to provide sufficient air movement in the shed. In sub-mountainous region, the buildings should be so sited as to avail of the natural aeration and drying.

#### 4. HERD SIZE

4.1 It is assumed that producers in this interest shall normally maintain a herd of about 130 animals consisting of 40 milch animals, 40 dry animals, two bulls, and the rest comprising followers, as also about three pairs of bullocks.

#### 5. BUILDING UNITS

5.1 The units should comprise sheds ( *see 5.1.1* ) for housing different categories of animals and the necessary ancillary structures ( *see 5.1.2* ) required for this interest.

5.1.1 *Sheds* — Various types of sheds ( *see 7* ) that are required under this interest are as follows:

- a) Milch animals shed,
- b) Dry animal shed,
- c) Down-calver shed,
- d) Sick-animal shed,
- e) Young stock shed,
- f) Calf shed, and
- g) Bull shed.

5.1.1.1 There shall be a paddock attached to each of the sheds.

5.1.2 The ancillary structures ( *see 10* ) required under this interest shall be as follows:

- a) Milk collection, recording and testing room;
- b) Utensils room;
- c) Ration room;
- d) Store;
- e) Office room;
- f) Fodder processing and storage room;
- g) Trevis; and
- h) Foot bath.

#### 6. LAYOUT

6.1 A typical layout comprising the various units is given in Fig. 1.

**NOTE** — The layout with these units could be modified depending upon local conditions like shape, size and topography of available land, size of enterprises, finances, etc.

## 7. DESCRIPTION OF SHEDS

**7.1 Milch Animal Shed** — The standings of the milch animal shed shall be of a tail-to-tail system with a central passage. The length and width of the standing shall be decided according to the size of the animal and may vary from 1.5 to 1.7 m in length and 1.0 to 1.2 m in width. In coastal region, sometimes buffaloes with spreading horns are found in that case width per animal may vary from 1.2 to 1.3 m.

**7.1.1** The width of the central passage may be 1.8 m. The central passage shall be sloped from the centre outwards towards drains. There shall be a drain on either side of the central passage.

**7.1.2** There shall be two continuous manger ( *see 8.2* ), one on each side in front of the standings with a cross passage of one metre width at the end of every 8 standings for easy movement.

**7.1.3** There shall be pillars ( *see 8.4* ) along with length of the sheds to support the beam of the roof. The roof of the shed shall be gabled ( *see 8.6* ).

**7.1.4** The shed may, if necessary, be extended to accommodate calving ( *see 7.3* ) as also calves ( *see 7.6* ).

**7.2 Dry Animal Shed** — The standings of the shed shall be constructed on the head-to-head system with a central manger and if in a single line, facing the wall ( *see Fig. 1* ). The length and width of each standing shall be in the same range as specified for the milch animals ( *see 7.1* ). There shall be a drain behind each line of animals. There shall be pillars along the length of the sheds to support the beam of the roof and walls at each end. The roof of the shed shall be gabled. The dry animal shed may be extended to accommodate the young stock as well ( *see 7.5* ).

**7.2.1** The bullocks may be accommodated with dry animals or a separate provision for bullock shed may be made. If a separate provision for bullock shed is made, a cart shed may also be attached to it.

**7.3 Calving Animal Shed** — The shed shall have two calving boxes for housing animals very close to calving and standings adjacent to the boxes for accommodating heavy-in-calf. Provision for this should generally be made at the rate of 5 percent of the adult females. A calving attendant room may also be provided in the shed.

**7.3.1 Calving Boxes** — The calving boxes shall be adjacent to each other and shall be at the end of the shed separated by a wall from the standings. The wall partition between the two calving boxes may be 1.25 m high. The dimension of each calving box shall be 3 × 4 m. A manger and a water trough, each 0.5 m wide inside, shall be constructed

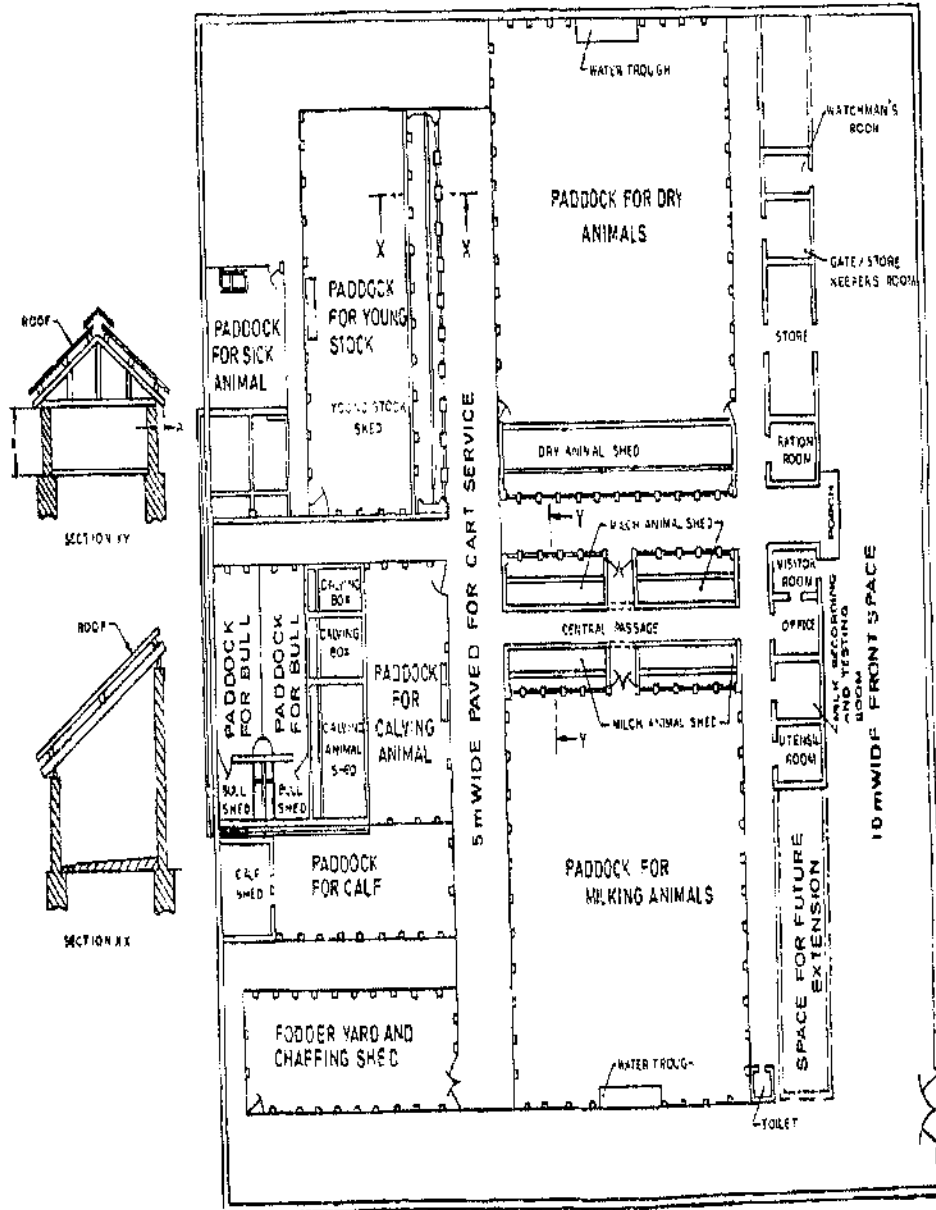

FIG. 1 TYPICAL LAYOUT OF FARM CATTLE SHED FOR GAUBHALAS' AND OTHER ORGANISED MILK PRODUCERS (Continued)

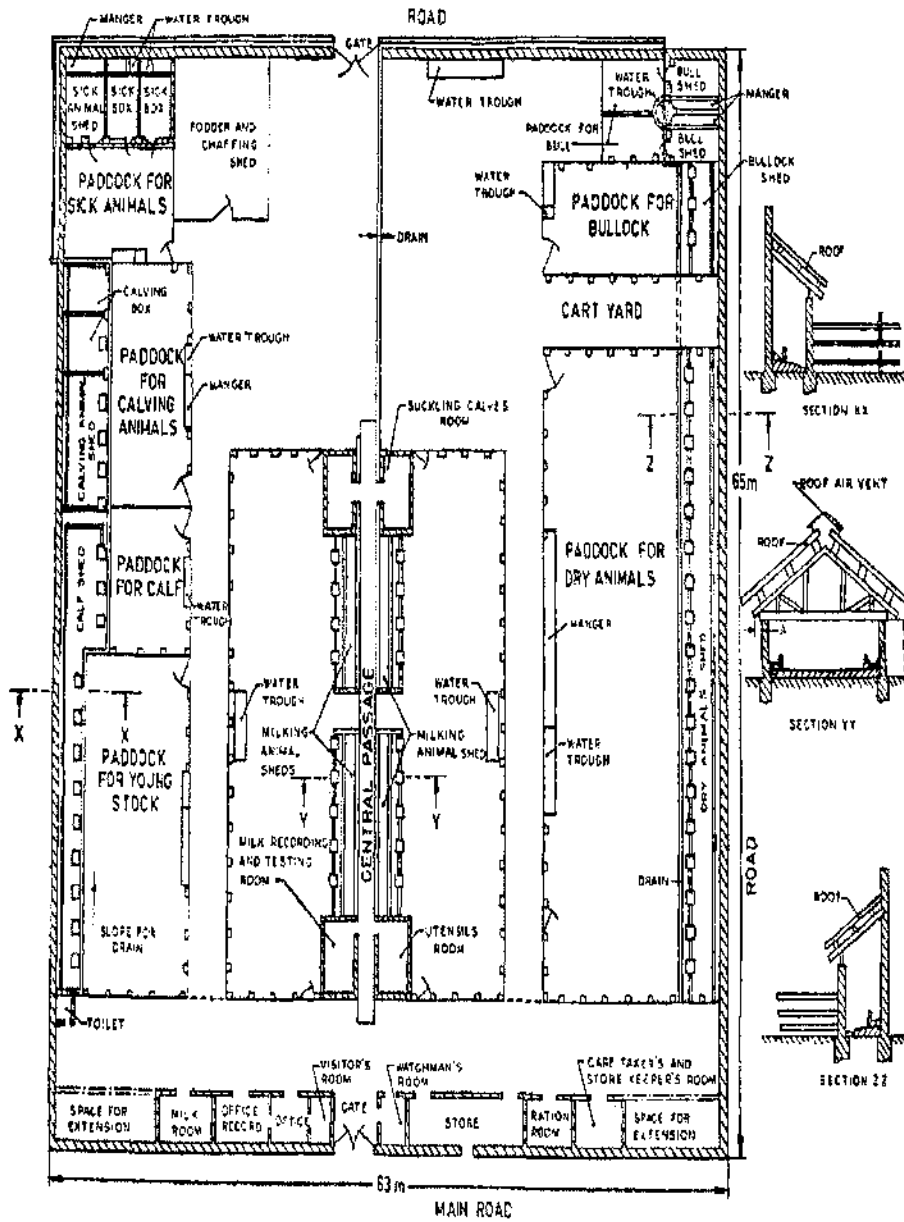

FIG. 1 TYPICAL LAYOUT OF FARM CATTLE SHED FOR GAUSHALAS AND OTHER ORGANISED MILK PRODUCERS



at the two separate corners of each of the calving boxes or a trough throughout the width of the box. A single-leaf door 2 m high and 1.2 m wide shall be provided for each of the calving boxes. The flooring of the calving boxes and standings shall be sloped towards the wall and into a drain running outside the shed.

**7.3.2 Standings** — The standings of the down-calver shed shall be constructed in such a way that animals are kept tethered facing the wall. There shall be a continuous manger along the wall. The length and width of each standing shall be 2.0 m and 1.6 m respectively.

**7.4 Sick Animal Shed** — The sick animal shed shall be located well away from the other sheds inaccessible to other animals. The dimensions and arrangements for sick animal shed shall be the same as in 7.3.1 and 7.3.2.

**7.5 Young Stock Shed** — The young stock shed may be an extension of the dry animals shed or a separate unit. In case the young stock shed is a separate unit to economize cost and space, the shed shall be constructed in such a way that young animals are tethered in two rows facing each other with a central manger. The length and width of each standing shall be 1.4 and 1.0 m respectively. The two drains of the shed shall be laid on either side of the standings. The roof of the shed shall be gabled and shall be supported on the length of the shed by a series of pillars and walls at each end. The young stock standings may alternatively be in a single line against a wall and the drains located suitably.

**7.6 Calf Shed** — The calf shed may be annexed either at the end or on the side to the milch animal shed and the calves may be separated from the milch animals by a suitable partition. If there is a large number of calves, the calf shed may form a separate unit. The dimensions of the calf shed shall depend upon the number of calves. The floor space provided per calf shall be not less than 1 m<sup>2</sup>. The calves may be kept loose. The manger shall be constructed along the walls of the three sides of the shed. There shall be a central shallow saucer-shaped drain. The roof may be either lean-to-type or gabled. A water trough shall be provided at one corner of the shed.

**7.7 Bull Shed** — The bull shed shall have two boxes each measuring 4 × 3 m. The walls may be 1.5 m high. A 0.5 m wide raised manger with feed and water sections shall be provided in each box. The two boxes shall lead to separate paddocks.

## **8. CONSTRUCTIONAL DETAILS OF SHEDS**

**8.1 Floor** — The floor may be either of *MOORUM*, *KANKAR*, cement concrete, brick-on-edge or stone slabs. The details of laying of flooring

IS : 11942 - 1986

are given in Appendix A of IS : 11786-1986\*. In case of cement concrete flooring, the surface shall be properly grooved in order to avoid slipping of the animals. For larger animals, the grooves shall be formed in square of  $15 \times 15$  cm and for calves  $10 \times 10$  cm (see A in Fig. 2). The width of the groove shall be 12 mm and depth 10 mm. The groove shall be of U shape. A plinth of at least 15 cm shall be provided for the floor. A slope of 1 in 60 towards the drains shall be provided in order to keep floor properly drained after washing.

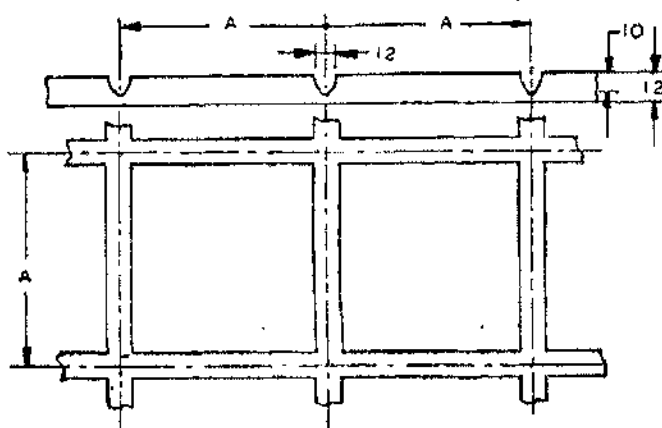

All dimensions in millimetres.

FIG. 2 CROSS-SECTION OF STANDING

**8.2 Manger** — The manger shall be of continuous type. The manger shall be made of reinforced cement concrete, stone slabs, or brick-in-lime or cement mortar. The flooring material of the manger shall be the same as for the floor but the surface shall be finished smooth. All the corners of the manger shall be rounded off and finished smooth. The dimensions of the manger (see Fig. 3) shall be as given in Table 1. In case the mangers are of brick, the fore curb should be topped with angle iron.

**8.2.1 Water Supply** — There shall be an adequate supply of potable water in the shed. One of the ways of supplying water in the shed may be that water trough of 20 cm diameter may be constructed on the manger wall. Water shall be allowed to flow through these troughs so that fresh water may be made available to the animals, calculated at the rate of 50 litres per livestock unit per day. These troughs may be placed between the two standings. The water troughs should be provided with railing on its sides so that the animals may not try to step in the water

\*Recommendations of cattle housing for an average farmer.

trough and contaminate it. When a piped water supply is available, a shallow water trough having its slope towards one end, and having a balancing float tank at the other end, ensures fresh water supply.

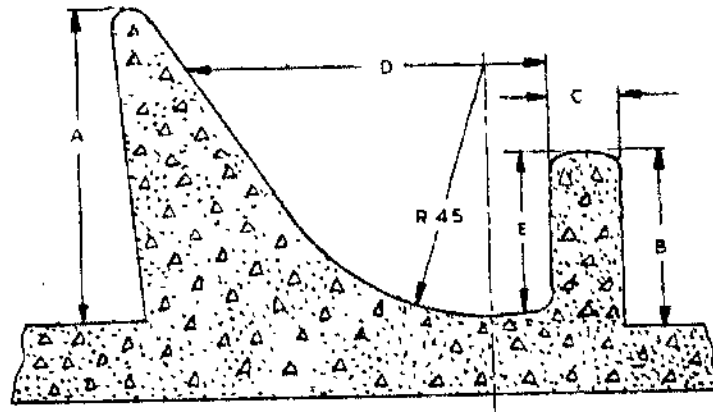

All dimensions in millimetres.

FIG. 3 CROSS-SECTION OF MANGER

TABLE 1 DIMENSIONS OF MANGER

( Clause 8.2 )

( All dimensions in cm )

Sl. No.	PARTICULARS	REINFORCED CEMENT CONCRETE	BRICK LAID IN CEMENT	STONE SLAB	REF TO FIG. 3
(1)	(2)	(3)	(4)	(5)	(6)
i)	Height of manger wall, <i>Min</i>	75	75	75	A
ii)	Height of fore curb <i>Max</i>				
a)	For adults	50	50	50	B
b)	For calves	30	30	30	
iii)	Thickness of fore curb, <i>Min</i>	10	10	4	C
iv)	Inner width of manger, <i>Min</i>				
a)	For adults	60	60	60	D
b)	For calves	40	40	40	
v)	Depth of manger, <i>Min</i>				
a)	For adults	40	40	40	E
b)	For calves	15	15	15	

**IS : 11942 - 1986**

**8.3 Drains** — The drains shall be made of brick in cement mortar or of stone and shall be of shallow U type with a depth of 6 cm at the bottom. The slope of the drain shall be 1 in 100 to 1 in 120. The width of the drains may vary between 30 and 40 cm. Where a long running shed is constructed, connecting drains at right angles should be provided after every 15 standings. The main drain may be led to a common urine pit having a depth not exceeding 40 cm or to the field if slope permits. The urine pit may be circular or rectangular.

**8.4 Pillars** — One pillar shall be placed at intervals of every two or three standings depending upon the width of each standing. Pillars may be made from any of the following materials and their minimum dimensions shall be as indicated against each:

- |  |  |
|--|--|
| a) Brick   | 45 × 35 cm ( see Note 1 ), or<br>40 × 30 cm ( see Note 2 ) |
| b) Mild steel I Section                                    | 10 × 10 cm   |
| c) Stone   | 10 × 10 cm or 8 × 15 cm                                    |
| d) Iron pipes dia  | 10 cm  |
| e) Timber ( include palmira palm,<br>coconut and bamboo ): |  |
| 1) Rectangular pillars                                     | 10 × 10 cm   |
| 2) Round pole, dia   | 15 cm  |

NOTE 1 — In case of 22.5 × 11.25 cm brick, 2 lengths and 3 widths shall be used.

NOTE 2 — In case of 20 × 10 cm ( modular ) bricks, 2 lengths and 3 widths shall be used.

NOTE 3 — All iron structures shall be suitably painted for protection against corrosion.

**8.4.1** All edges in rectangular pillars shall be rounded off and finished smooth.

**8.5 Walls** — The wall shall be of brick or stone slab laid in cement mortar. The wall may be cement-plastered from inside. The thickness of the wall shall be at least 20 cm, however in case of bull shed it shall be at least 30 cm. All walls shall be solid up to 1.25 m height from the floor level and shall be constructed in honey comb pattern above that height in order to provide sufficient air movement in the shed. The rest of the portion of the wall may be left open by a series of wire-netted windows. In desert areas, the solid portion may extend up to 1.8 m in height. In case of lean-to-type system, the end walls above the solid portion may be left open or provided with a series of wire-netted windows.

**8.6 Roof**— The roof may be gabled, flat or lean-to-type. The roof may be constructed either of corrugated asbestos sheets or galvanized steel sheets or tiles (Country tiles are not recommended). The roof shall be supported by steel or wooden trusses or by a series of central pillars. The pitch of the roof may range between 22 to 30 degrees depending upon the materials used. Wooden purlins may be spaced up to 1.3 m apart. Generally, the eaves of the roof (see A in Fig. 1) shall project out at least 50 cm away from the pillars/walls and in regions where extreme climatic conditions prevail, the eaves of the roof may project up to 75 cm from the pillars/walls in order to afford protection to the animals from direct sun and rain. The eaves should be 2.2 m high from the ground level (see B in Fig. 1).

## 9. PADDOCKS OR YARD

**9.1** A paddock shall be attached to every shed for animals to move about freely. There may be trees in the paddock to provide enough shade. A part of the paddock may be paved with bricks laid on edge. The paddock shall have the following minimum space per animal for various categories of animals:

a) Buffaloes	8 m <sup>2</sup>
b) Cow	7 m <sup>2</sup>
c) Young stock	4 m <sup>2</sup>
d) Calf	2 m <sup>2</sup>
e) Calving	12 m <sup>2</sup>
f) Bull	25 m <sup>2</sup>

## 9.2 Fences

**9.2.1** The wall of bricks or stone slabs or a railing or wires may constitute fence. The railings may be of 35 mm galvanized iron pipe or 5 mm galvanized iron wire and posts to support railings. The posts may be of 5 cm steel pipe, 6 × 4 cm angle iron, 8 × 5 cm stone slabs or 10 × 10 cm timber placed 2 m apart. The posts shall be holed to pass the railings through or it may be riveted or 'U' bolted to the place. The railings for different categories of the animals shall be fixed with the posts as given below:

<i>Height from Ground to Centre of Each Rail</i>	<i>Calves</i>	<i>Cows, Young Stock and Buffaloes,</i>	<i>Bull</i>
	cm	cm	cm
First rail	30	40	40
Second rail	60	80	80
Third rail	90	120	120
Fourth rail	120	—	150

IS : 11942 - 1986

9.2.2 The wooden horizontal braces or steel horizontal braces shall be placed as given in Fig. 4. Braced steel end or corner posts shall be embedded as given in Fig. 5.

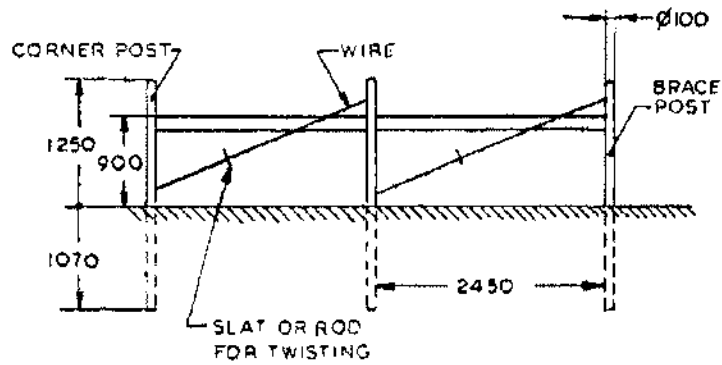

All dimensions in millimetres.

FIG. 4 WOOD OR STEEL HORIZONTAL BRACES

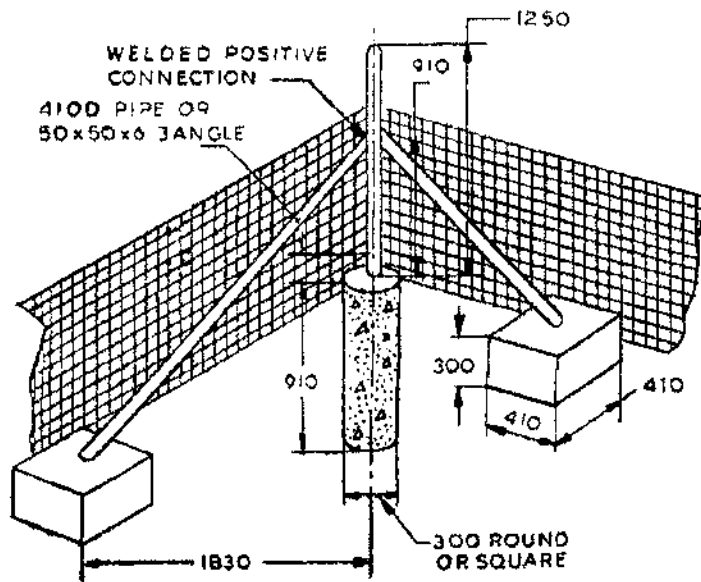

All dimensions in millimetres.

FIG. 5 BRACED STEEL END OR CORNER POST

**9.3 Gate** — A gate of suitable type and size may be provided taking care that they are hinged firmly and raised well above the ground. Braces shall be positioned vertically.

**9.4 Manger and Water Trough** — Manger and water trough may be constructed with reinforced cement concrete, brick with cement mortar or stone slabs with cement joining. A 2-m wide paved platform shall be provided away from trough to withstand the heavy treading of animals and permit easy washing and cleanliness.

## 10. ANCILLARY STRUCTURES

**10.1 Milk Collection, Recording and Testing Room** — There shall be a room of 4 × 3 m in or near the milch animal shed for collecting, recording and testing of milk. The door and the windows shall be made fly-proof. The flooring of the room shall be of cement concrete impervious and reinforced with iron strips at suitable distances to make it hard wearing. A suitable platform or a slab shall be provided for testing apparatus. A separate milk room may also be provided for handling milk.

**10.2 Utensils Room** — There shall be a room of 4 × 3 m for washing and storing milk cans. The flooring of the room shall be of hard-wearing type to withstand the frequent handling of heavy milk cans. The door and windows shall be made fly-proof. The room may be located as near as possible to the milk recording and testing room.

**10.3 Ration Room** — There shall be a room of at least 4 × 3 m near to the milch animal shed to store feed concentrates temporarily to meet the requirements of the animals for the day. The ration room shall be damp- and rodent proof.

**10.4 Store** — The store shall be adequate to accommodate feed concentrate required for a period of about 2 months. The space required for storage shall be 0.2 m<sup>2</sup> per livestock unit. The store shall be made damp- and rodent-proof. A store keeper's room may also be attached to the store.

**10.5 Office Room** — Provision of an office accommodation is generally desirable in *GAUSHALAS* and similar organizations. The office room may also be used for keeping medicines and instruments required for treating sick animals. The dimensions of the office room shall depend upon the space available and the size of the enterprise. A toilet may also be provided. A visitor's room may also be attached to the office room.

**10.6 Trevis or Cattle Crutch** — A cattle trevis may be provided to secure the animals for rendering first-aid and artificial insemination.

**IS : 11942 - 1986**

**10.7** Adequate provision shall be made for storage of roughages.

**10.8** A provision shall be made for a suitable foot bath at the entrance gate.

**10.9** Provision may be made for a segregation room for keeping new animals introduced in the herd for some initial days before their mixing up with the herd.

**10.10 Lighting** — Provision of lighting shall be made in case electricity is available, a 25 W bulb for each 10 m<sup>2</sup> space or 60 W bulb for each 20 m<sup>2</sup> space or equivalent fluorescent tube light may be provided.

**10.11 Waste Handling System** — Bio-gas plant of suitable size should be installed. The animal waste (dung, urine and other biomass) should be fed to the plant.



## BUREAU OF INDIAN STANDARDS

*Headquarters:*

Manak Bhavan, 9 Bahadur Shah Zafar Marg, NEW DELHI 110002

Telephones : 331 0131 331 1375      Telegrams : Manaksanstha  
( Common to all Offices )

*Regional Offices:*

<i>Regional Offices:</i>	<i>Telephone</i>
*Western : Manakalaya, E9 MIDC, Marol Andheri ( East ) BOMBAY 400093	6 32 92 95
†Eastern : 1/14 C. I. T. Scheme VII M, V. I. P. Road, Maniktola, CALCUTTA 700054	36 24 99
Northern : SCO 445-446, Sector 35-C CHANDIGARH 160036	{ 2 18 43 3 16 41
Southern : C. I. T. Campus, MADRAS 600113	{ 41 24 42 41 25 19 41 29 16

*Branch Offices:*

'Pushpak', Nurmohamed Shaikh Marg, Khanpur AHMADABAD 380001	{ 2 63 48 2 63 49
'F' Block, Unity Bldg, Narasimharaja Square, BANGALORE 560002	22 48 05
Gangotri Complex, 5th Floor, Bhadbhada Road, T. T. Nagar, BHOPAL 462003	6 67 16
Plot No. 82/83, Lewis Road, BHUBANESHWAR 751002	6 36 27
53/5 Ward No. 29, R. G. Barua Road, 5th Byelane, GUWAHATI 781003	—
5-8-56C L.N. Gupta Marg, HYDERABAD 500001	23 10 83
R14 Yudhister Marg, C Scheme, JAIPUR 302005	{ 6 34 71 6 98 32
117/418 B Sarvodaya Nagar, KANPUR 208005	{ 21 68 76 21 82 92
Patliputra Industrial Estate, PATNA 800013	6 23 05
Hantex Bldg (2nd Floor), Rly Station Road, TRIVANDRUM 695001	52 27
<i>Inspection Office (With Sale Point):</i>	
Institution of Engineers (India) Building, 1332 Shivaji Nagar, PUNE 411005	6 24 35

---

*Sales Office in Bombay is at Novelty Chambers, Grant Road, BOMBAY 400007	89 66 28
†Sales Office in Calcutta is at 5 Chowringhee Approach, P.O. Princep Street, CALCUTTA 700072	27 68 00

Printed at Printograph, New Delhi, India

**Inventory Performa for Dairy Farms and Gaushalas in the State/UT**

Sl. No.	Description	Urban Area	Peri-urban Area	Rural Area
1.	Total no. of dairy farms <ul style="list-style-type: none"> <li>• Small (upto 25 animals)</li> <li>• Medium (upto 100 animals)</li> <li>• Large (above 100 animals)</li> <li>• Total</li> </ul>	• • • •	• • • •	• • • •
2.	Total no. of animals in <ul style="list-style-type: none"> <li>• Small dairy farms</li> <li>• Medium dairy farms</li> <li>• Large dairy farms</li> <li>• Total</li> </ul>	• • • •	• • • •	• • • •
3.	Total amount of bovine dung produced (ton per day) by <ul style="list-style-type: none"> <li>• Small dairy farms</li> <li>• Medium dairy farms</li> <li>• Large dairy farms</li> <li>• Total</li> </ul>	• • • •	• • • •	• • • •
4.	Methods of disposal/utilization of bovine dung and wastewater by dairy farms (to be enclosed)			
5.	Total no. of dairy colonies/clusters  (list of such dairy colonies/clusters along with the details of no. of dairies, no. of bovine, method of disposal/utilization of bovine dung & wastewater, etc. to be enclosed)	•	•	•

6.	Total no. of Gaushalas <ul style="list-style-type: none"> <li>• Small (upto 100 animals)</li> <li>• Medium (upto 1000 animals)</li> <li>• Large (above 1000 animals)</li> <li>• Total</li> </ul>	• • • •	• • • •	• • • •
7.	Total no. of animals in <ul style="list-style-type: none"> <li>• Small Gaushalas</li> <li>• Medium Gaushalas</li> <li>• Large Gaushalas</li> <li>• Total</li> </ul>	• • • •	• • • •	• • • •
8.	Total amount of dung produced (ton per day) by <ul style="list-style-type: none"> <li>• Small Gaushalas</li> <li>• Medium Gaushalas</li> <li>• Large Gaushalas</li> <li>• Total</li> </ul>	• • • •	• • • •	• • • •
9.	Methods of disposal/utilization of dung and wastewater by Gaushalas (to be enclosed)			

**Note:**

Urban area: As per the Census of India 2011, the urban area is defined as follows:

- i. All places with a municipality, corporation, cantonment board or notified town area committee, etc.
- ii. All other places which satisfied the following criteria:
  - a. A minimum population of 5,000;
  - b. At least 75 per cent of the male main working population engaged in non-agricultural pursuits; and
  - c. A density of population of at least 400 persons per sq. km.

Peri-urban area: It is an area or habitation located on the perimeter of the urban area having partial or complete influence of urbanization.

Dairy colonies/cluster: It is defined as the area designated by the government for the purpose of dairy activities.

\*\*\*\*\*