

Hy-Line[®]

BROWN

Conventional Systems



Management Guide



Summary of Performance Standards

REARING PERIOD (TO 17 WEEKS):	
Livability	98%
Feed Consumed	6069 g
Body Weight at 17 Weeks	1580 g
LAYING PERIOD (TO 90 WEEKS):	
Percent Peak	94.8–96.6%
Hen-Day Eggs to 60 Weeks	257.5–269.0
Hen-Day Eggs to 72 Weeks	328.9–343.4
Hen-Day Eggs to 90 Weeks	425.5–445.2
Hen-Housed Eggs to 60 Weeks	254.1–265.5
Hen-Housed Eggs to 72 Weeks	323.3–337.7
Hen-Housed Eggs to 90 Weeks	415.0–434.2
Livability to 60 Weeks	97.4%
Livability to 80 Weeks	95.1%
Livability to 90 Weeks	93.5%
Days to 50% Production (from hatch)	144
Egg Weight at 26 Weeks	59.2 g
Egg Weight at 32 Weeks	61.9 g
Egg Weight at 72 Weeks	64.8 g
Total Egg Mass per Hen-Housed (18–90 weeks)	26.8 kg
Body Weight at 32 Weeks	1.93–2.07 kg
Body Weight at 72 Weeks	1.96–2.10 kg
Freedom From Egg Inclusions	Excellent
Shell Strength	Excellent
Shell Color Score at 38 Weeks	87
Shell Color Score at 56 Weeks	85
Shell Color Score at 72 Weeks	81
Shell Color Score at 90 Weeks	79
Haugh Units at 38 Weeks	90.0
Haugh Units at 56 Weeks	84.0
Haugh Units at 72 Weeks	81.0
Haugh Units at 90 Weeks	79.7
Average Daily Feed Consumption (18–90 weeks)	110.7 g/day per bird
Feed Conversion Rate, kg Feed/kg Eggs (20–60 weeks)	1.90–2.06
Feed Conversion Rate, kg Feed/kg Eggs (20–72 weeks)	1.91–2.08
Feed Conversion Rate, kg Feed/kg Eggs (20–90 weeks)	1.98–2.15
Feed Utilization, kg Egg/kg Feed (20–60 weeks)	0.49–0.53
Feed Utilization, kg Egg/kg Feed (20–72 weeks)	0.48–0.52
Feed Utilization, kg Egg/kg Feed (20–90 weeks)	0.46–0.50
Feed Consumption per 10 Eggs (20–60 weeks)	1.19–1.23 kg
Feed Consumption per 10 Eggs (20–72 weeks)	1.21–1.24 kg
Feed Consumption per 10 Eggs (20–90 weeks)	1.26–1.29 kg
Feed Consumption per Dozen Eggs (20–60 weeks)	1.43–1.47 kg
Feed Consumption per Dozen Eggs (20–72 weeks)	1.45–1.49 kg
Feed Consumption per Dozen Eggs (20–90 weeks)	1.51–1.55 kg
Skin Color	Yellow
Condition of Droppings	Dry

Performance Summary data is based on results obtained from customers around the world. Please send your results to info@hyline.com. An easy to use record-keeping programme, **Hy-Line International EggCel**, is available.

Rearing Period Performance Table

AGE (weeks)	MORTALITY Cumulative (%)	BODY WEIGHT (g)	WATER INTAKE (ml/bird/day)	FEED INTAKE (g/bird/day)	CUMULATIVE FEED INTAKE (g/bird to date)	UNIFORMITY %
1	0.40	70 – 80	18–28	12 – 14	84 – 98	
2	0.55	115 – 145	25–42	17 – 21	201 – 244	>85%
3	0.65	190 – 220	30–50	20 – 25	343 – 418	
4	0.75	270 – 320	37–60	25 – 30	515 – 627	
5	0.85	360 – 420	43–73	29 – 36	717 – 883	>80%
6	0.95	470 – 520	52–89	35 – 44	960 – 1193	
7	1.05	570 – 640	62–98	41 – 49	1249 – 1537	
8	1.15	680 – 760	71–112	47 – 56	1580 – 1929	
9	1.25	780 – 880	78–122	52 – 61	1943 – 2355	
10	1.35	885 – 995	84–129	56 – 64	2334 – 2806	
11	1.45	995 – 1105	90–137	60 – 69	2754 – 3287	
12	1.55	1095 – 1205	93–144	62 – 72	3189 – 3791	>85%
13	1.63	1175 – 1295	96–148	64 – 74	3637 – 4308	
14	1.70	1265 – 1365	99–154	66 – 77	4099 – 4845	
15	1.78	1345 – 1445	102–158	68 – 79	4575 – 5399	
16	1.85	1410 – 1510	105–164	70 – 82	5066 – 5973	
17	2.00	1485 – 1590	108–170	72 – 85	5570 – 6568	>90%

Production Period Performance Table

AGE (weeks)	% HEN-DAY Current	HEN-DAY EGGS Cumulative	HEN-HOUSED EGGS Cumulative	MORTALITY Cumulative (%)	BODY WEIGHT (kg)	WATER INTAKE (ml/bird/day)	FEED INTAKE (g/bird/day)	HH EGG MASS Cumulative (kg)	AVG. EGG WT. (g/egg)
18	1.1–7.7	0.1–0.5	0.1 –0.5	0.05	1.55 – 1.67	110–176	73–88	–	46.5
19	8.2–27.1	0.7–2.4	0.7 –2.4	0.08	1.62 – 1.74	127–188	85–94	0.1	49.3
20	30.8–57.3	2.8–6.4	2.8 –6.4	0.13	1.68 – 1.80	135–197	90–99	0.2	51.6
21	61.4–80.5	7.1–12.1	7.1 –12.1	0.20	1.73 – 1.85	142–205	95–103	0.5	53.5
22	82.4–90.6	12.9–18.4	12.8 –18.4	0.27	1.77 – 1.89	148–215	99–107	0.8	55.0
23	90.6–94.1	19.2–25.0	19.2 –25.0	0.34	1.80 – 1.92	154–222	102–111	1.2	56.4
24	93.2–95.5	25.7–31.7	25.7 –31.6	0.40	1.82 – 1.95	159–228	106–114	1.6	57.5
25	94.2–96.2	32.3–38.4	32.2 –38.3	0.46	1.84 – 1.98	162–230	108–115	2.0	58.4
26	94.6–96.4	39.0–45.2	38.8 –45.0	0.50	1.86 – 2.00	163–231	109–116	2.4	59.2
27	94.8–96.6	45.6–51.9	45.4 –51.8	0.55	1.88 – 2.01	164–232	109–116	2.8	59.9
28	94.8–96.6	52.2–58.7	52.0 –58.5	0.61	1.89 – 2.03	164–233	109–116	3.2	60.4
29	94.8–96.6	58.9–65.5	58.6 –65.2	0.66	1.90 – 2.04	164–233	109–117	3.6	60.9
30	94.8–96.5	65.5–72.2	65.2 –71.9	0.71	1.91 – 2.05	164–233	109–117	4.0	61.3
31	94.7–96.5	72.1–79.0	71.8 –78.6	0.76	1.92 – 2.06	164–233	109–117	4.4	61.7
32	94.7–96.5	78.8–85.7	78.4 –85.3	0.80	1.93 – 2.07	164–234	109–117	4.8	62.0
33	94.6–96.3	85.4–92.5	84.9 –92.0	0.86	1.93 – 2.07	164–233	109–117	5.2	62.3
34	94.4–96.1	92.0–99.2	91.5 –98.7	0.92	1.94 – 2.08	164–233	109–117	5.6	62.5
35	94.2–96.0	98.6–105.9	98.0 –105.3	0.97	1.94 – 2.08	163–233	109–117	6.0	62.7
36	94.0–95.8	105.2–112.6	104.5 –111.9	1.02	1.95 – 2.08	163–233	109–116	6.4	62.9
37	93.7–95.7	111.7–119.3	111.0 –118.6	1.08	1.95 – 2.09	163–233	109–116	6.9	63.1
38	93.5–95.5	118.3–126.0	117.5 –125.2	1.12	1.95 – 2.09	163–232	109–116	7.3	63.2
39	93.3–95.3	124.8–132.7	123.9 –131.8	1.18	1.95 – 2.09	163–232	109–116	7.7	63.3
40	93.1–95.0	131.3–139.3	130.4 –138.3	1.24	1.95 – 2.09	163–232	108–116	8.1	63.4
41	92.8–94.9	137.8–146.0	136.8 –144.9	1.30	1.96 – 2.09	163–232	108–116	8.5	63.5
42	92.5–94.6	144.3–152.6	143.2 –151.4	1.35	1.96 – 2.10	163–232	108–116	8.9	63.6
43	92.1–94.4	150.8–159.2	149.5 –157.9	1.41	1.96 – 2.10	163–232	108–116	9.3	63.7
44	91.8–94.1	157.2–165.8	155.9 –164.4	1.47	1.96 – 2.10	163–232	108–116	9.7	63.8
45	91.5–93.8	163.6–172.3	162.2 –170.9	1.52	1.96 – 2.10	163–232	108–116	10.1	63.9
46	91.2–93.5	170.0–178.9	168.4 –177.3	1.59	1.96 – 2.10	163–232	108–116	10.5	63.9
47	90.9–93.3	176.3–185.4	174.7 –183.8	1.64	1.96 – 2.10	163–232	108–116	10.9	64.0
48	90.7–93.1	182.7–191.9	181.0 –190.2	1.70	1.96 – 2.10	163–232	108–116	11.4	64.0
49	90.4–92.8	189.0–198.4	187.2 –196.5	1.76	1.96 – 2.10	163–232	108–116	11.8	64.1
50	90.0–92.7	195.3–204.9	193.4 –202.9	1.83	1.96 – 2.10	163–232	108–116	12.2	64.1
51	89.8–92.4	201.6–211.4	199.5 –209.3	1.89	1.96 – 2.10	163–232	108–116	12.6	64.2
52	89.6–92.2	207.9–217.8	205.7 –215.6	1.95	1.96 – 2.10	163–232	108–116	13.0	64.2
53	89.4–91.9	214.1–224.3	211.8 –221.9	2.01	1.96 – 2.10	163–232	108–116	13.4	64.3
54	89.3–91.7	220.4–230.7	217.9 –228.2	2.09	1.96 – 2.10	163–232	108–116	13.8	64.3
55	88.9–91.5	226.6–237.1	224.0 –234.4	2.16	1.96 – 2.10	163–232	108–116	14.2	64.3
56	88.7–91.4	232.8–243.5	230.1 –240.7	2.24	1.96 – 2.10	163–232	108–116	14.5	64.4
57	88.4–91.2	239.0–249.9	236.1 –246.9	2.33	1.96 – 2.10	163–232	108–116	14.9	64.4
58	88.2–91.0	245.2–256.3	242.2 –253.2	2.40	1.96 – 2.10	163–232	108–116	15.3	64.4

Hy-Line Brown - Conventional Systems

AGE (weeks)	% HEN-DAY Current	HEN-DAY EGGS Cumulative	HEN-HOUSED EGGS Cumulative	MORTALITY Cumulative (%)	BODY WEIGHT (kg)	WATER INTAKE (ml/bird/day)	FEED INTAKE (g/bird/day)	HH EGG MASS Cumulative (kg)	AVG. EGG WT. (g/egg)
59	87.9-90.8	251.3-262.6	248.2 -259.4	2.49	1.96 - 2.10	163-232	108-116	15.7	64.5
60	87.6-90.5	257.5-269.0	254.1 -265.5	2.57	1.96 - 2.10	163-232	108-116	16.1	64.5
61	87.3-90.2	263.6-275.3	260.1 -271.7	2.65	1.96 - 2.10	163-232	108-116	16.5	64.6
62	87.0-90.0	269.7-281.6	266.0 -277.8	2.77	1.96 - 2.10	163-232	108-116	16.9	64.6
63	86.7-89.8	275.7-287.9	271.9 -283.9	2.85	1.96 - 2.10	163-232	108-116	17.3	64.6
64	86.4-89.6	281.8-294.1	277.8 -290.0	2.92	1.96 - 2.10	163-232	108-116	17.7	64.6
65	86.1-89.3	287.8-300.4	283.6 -296.1	2.97	1.96 - 2.10	163-232	108-116	18.1	64.7
66	85.6-89.0	293.8-306.6	289.4 -302.1	3.08	1.96 - 2.10	163-232	108-116	18.4	64.7
67	85.1-88.6	299.7-312.8	295.2 -308.1	3.14	1.96 - 2.10	163-232	108-116	18.8	64.7
68	84.5-88.3	305.7-319.0	300.9 -314.1	3.20	1.96 - 2.10	163-232	108-116	19.2	64.7
69	83.8-88.0	311.5-325.2	306.6 -320.1	3.30	1.96 - 2.10	163-232	108-116	19.6	64.8
70	83.2-87.6	317.4-331.3	312.2 -326.0	3.43	1.96 - 2.10	163-232	108-116	20.0	64.8
71	82.7-87.0	323.1-337.4	317.8 -331.9	3.58	1.96 - 2.10	163-232	108-116	20.3	64.8
72	82.0-86.4	328.9-343.4	323.3 -337.7	3.73	1.96 - 2.10	163-232	108-116	20.7	64.9
73	81.4-85.8	334.6-349.4	328.8 -343.5	3.88	1.96 - 2.10	163-232	108-116	21.1	64.9
74	80.7-85.2	340.2-355.4	334.2 -349.2	4.03	1.96 - 2.10	163-232	108-116	21.4	64.9
75	80.1-84.6	345.8-361.3	339.6 -354.9	4.18	1.96 - 2.10	163-232	108-116	21.8	64.9
76	79.5-84.0	351.4-367.2	344.9 -360.5	4.33	1.96 - 2.10	163-232	108-116	22.1	64.9
77	78.9-83.4	356.9-373.1	350.2 -366.1	4.48	1.96 - 2.10	163-232	108-116	22.5	65.0
78	78.3-82.8	362.4-378.8	355.4 -371.6	4.63	1.96 - 2.10	163-232	108-116	22.8	65.0
79	77.7-82.2	367.8-384.6	360.6 -377.1	4.78	1.96 - 2.10	163-232	108-116	23.2	65.0
80	77.1-81.6	373.2-390.3	365.7 -382.5	4.93	1.96 - 2.10	163-232	108-116	23.5	65.0
81	76.6-81.0	378.6-396.0	370.8 -387.9	5.08	1.96 - 2.10	163-232	108-116	23.9	65.0
82	76.1-80.4	383.9-401.6	375.8 -393.2	5.23	1.96 - 2.10	163-232	108-116	24.2	65.1
83	75.6-79.8	389.2-407.2	380.9 -398.5	5.38	1.96 - 2.10	163-232	108-116	24.5	65.1
84	75.2-79.2	394.5-412.7	385.8 -403.7	5.53	1.96 - 2.10	163-232	108-116	24.9	65.1
85	74.8-78.6	399.7-418.2	390.8 -408.9	5.68	1.96 - 2.10	163-232	108-116	25.2	65.1
86	74.4-78.0	404.9-423.7	395.7 -414.1	5.83	1.96 - 2.10	163-232	108-116	25.5	65.2
87	74.0-77.4	410.1-429.1	400.5 -419.2	5.98	1.96 - 2.10	163-232	108-116	25.9	65.2
88	73.6-76.8	415.2-434.5	405.4 -424.2	6.13	1.96 - 2.10	163-232	108-116	26.2	65.2
89	73.3-76.3	420.4-439.8	410.2 -429.2	6.28	1.96 - 2.10	163-232	108-116	26.5	65.2
90	73.0-75.8	425.5-445.2	415.0 -434.2	6.45	1.96 - 2.10	163-232	108-116	26.8	65.3
91	72.7-75.3	430.6-450.4	419.7 -439.1	6.65	1.96 - 2.10	163-232	108-116	27.1	65.3
92	72.4-74.9	435.6-455.7	424.4 -444.0	6.85	1.96 - 2.10	163-232	108-116	27.4	65.3
93	72.1-74.5	440.7-460.9	429.1 -448.8	7.10	1.96 - 2.10	163-232	108-116	27.8	65.3
94	71.8-74.1	445.7-466.1	433.8 -453.6	7.30	1.96 - 2.10	163-232	108-116	28.1	65.3
95	71.5-73.7	450.7-471.2	438.4 -458.4	7.50	1.96 - 2.10	163-232	108-116	28.4	65.4
96	71.2-73.3	455.7-476.4	443.0 -463.2	7.60	1.96 - 2.10	163-232	108-116	28.7	65.4
97	70.9-72.9	460.7-481.5	447.6 -467.9	7.80	1.96 - 2.10	163-232	108-116	29.0	65.4
98	70.6-72.5	465.6-486.5	452.1 -472.5	8.00	1.96 - 2.10	163-232	108-116	29.3	65.4
99	70.3-72.1	470.5-491.6	456.7 -477.2	8.20	1.96 - 2.10	163-232	108-116	29.6	65.4
100	70.0-71.7	475.4-496.6	461.2 -481.8	8.40	1.96 - 2.10	163-232	108-116	29.9	65.5

Space Recommendations

Production Period Space Recommendations

		WEEKS OF AGE																						
		3															17	20	30	40	50	60	70	80
CONVENTIONAL AND COLONY CAGES																								
Floor Space																								
100–200 cm ² (50–100 birds / m ²)		310 cm ² (32 birds / m ²)														490 cm ² (20 birds / m ²) – 750 cm ² (13 birds / m ²)								
Nipple/Cup																								
1 / 12 birds		1 / 8 birds														1 / 12 birds or access to 2 drinkers								
Feeders																								
5 cm / bird		8 cm / bird														7–12 cm / bird								

Growth Curve

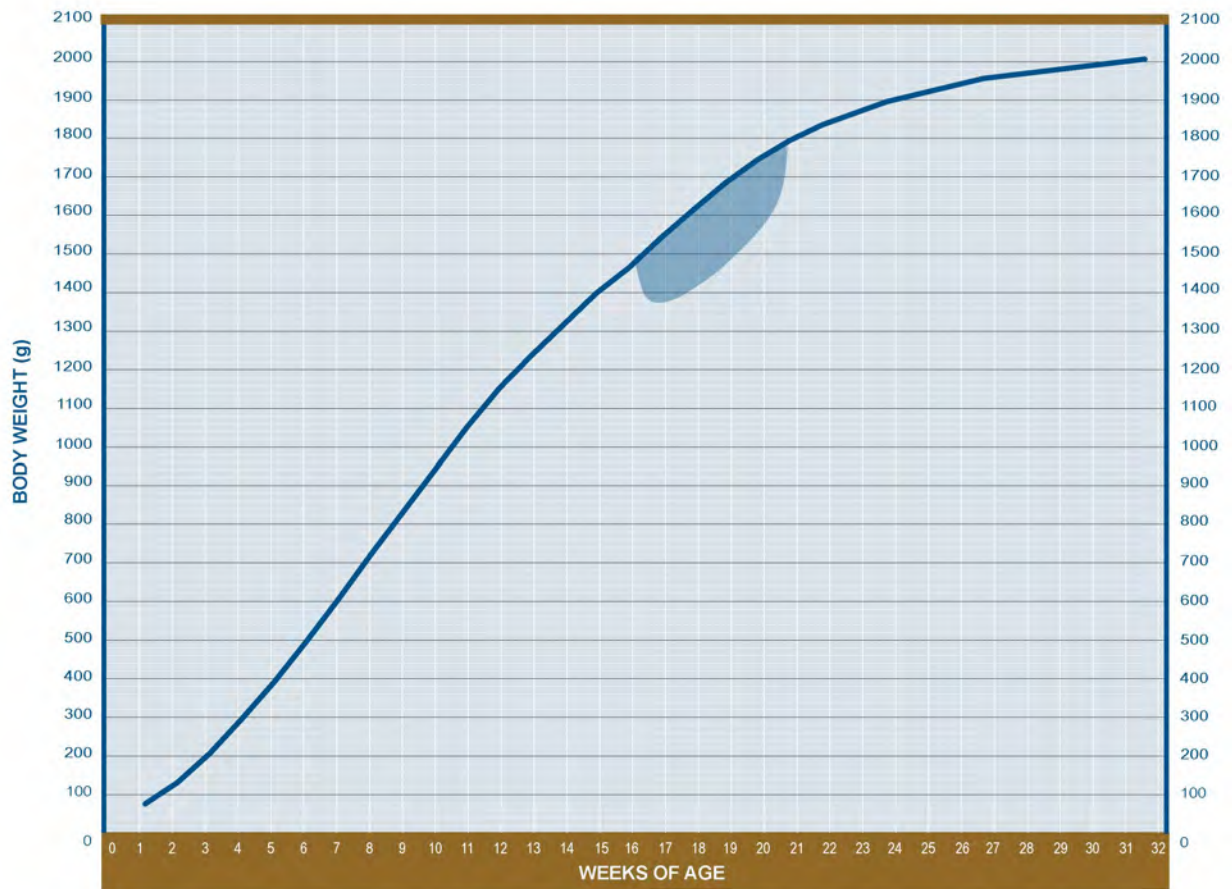

Blue shaded area represents potential body weight loss during transfer.

Performance Graph

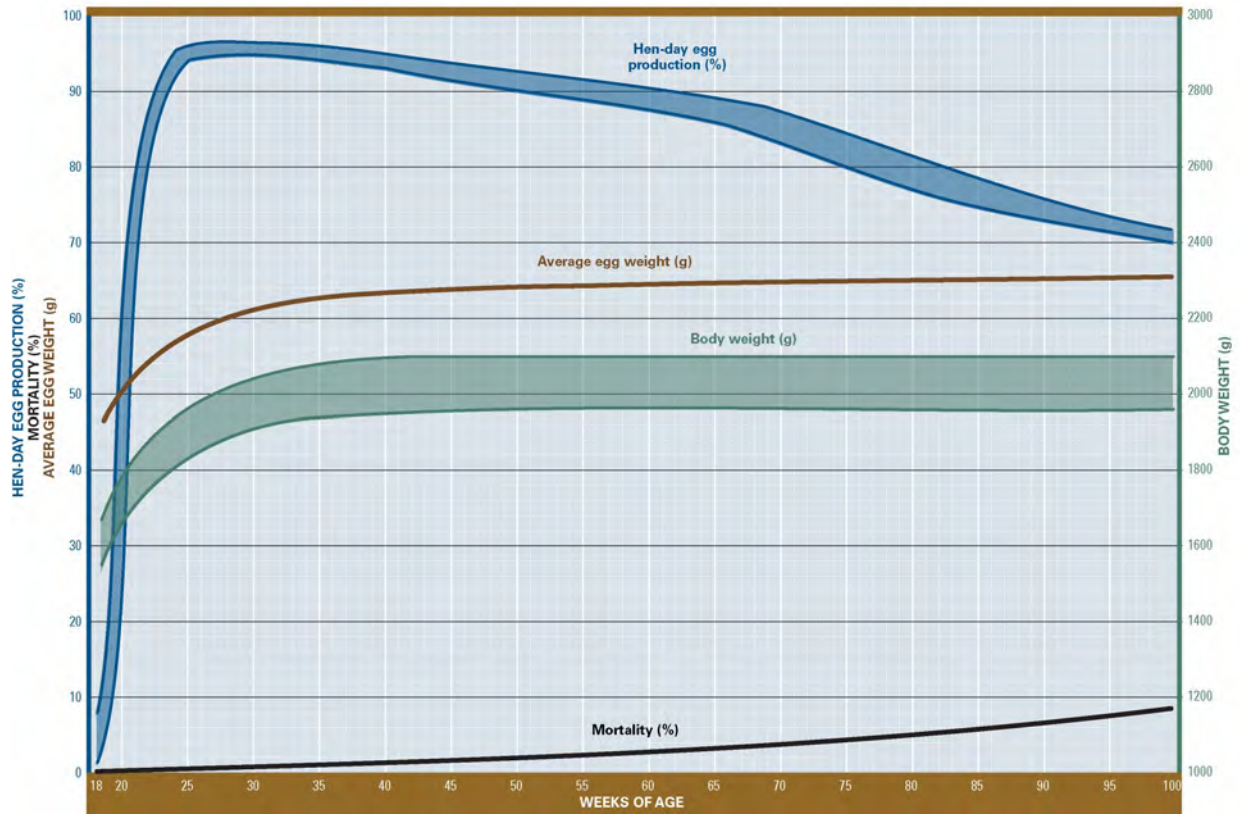

Egg Quality

AGE (weeks)	HAUGH UNITS	BREAKING STRENGTH	SHELL COLOUR
20	97.8	4605	89
22	97.0	4590	89
24	96.0	4580	89
26	95.1	4570	88
28	94.2	4560	88
30	93.3	4540	88
32	92.2	4515	88
34	91.5	4490	88
36	90.6	4450	87
38	90.0	4425	87
40	89.3	4405	87
42	88.5	4375	87
44	87.8	4355	87
46	87.1	4320	87
48	86.4	4305	87
50	85.6	4280	86
52	85.0	4250	86
54	84.6	4225	86
56	84.0	4190	85
58	83.1	4170	85
60	82.6	4150	85
62	82.2	4130	84
64	81.9	4110	83
66	81.6	4095	83
68	81.5	4085	82
70	81.1	4075	81
72	81.0	4065	81
74	80.8	4055	80
76	80.5	4040	80
78	80.2	4020	80
80	80.1	3995	80
82	80.0	3985	79
84	79.9	3975	79
86	79.8	3965	79
88	79.7	3960	79
90	79.7	3955	79

Egg shell colour is a genetically determined trait but environmental factors may reduce the intensity of the pigment. Certain diseases which infect the shell gland, such as infectious bronchitis and Egg Drop Syndrome, are known to reduce shell colour. Stress can result in the egg being held longer in the shell gland, resulting in white calcium carbonate deposition on the egg shell surface. Shell colour normally declines gradually with age.

For more information on egg quality, see [The Science of Egg Quality](#).

Shell Colour Scores

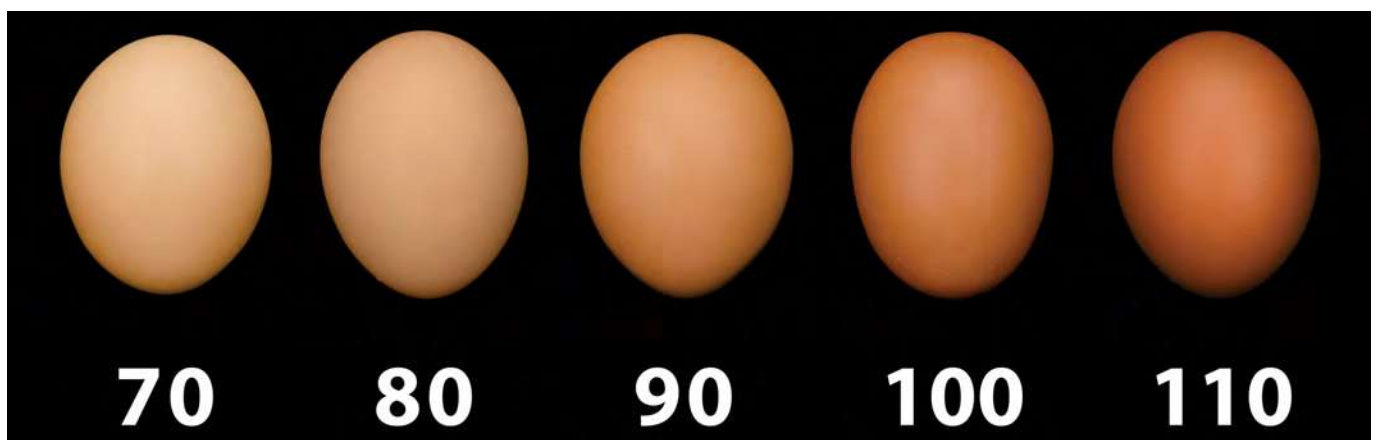

Egg Size Distribution - E.U.

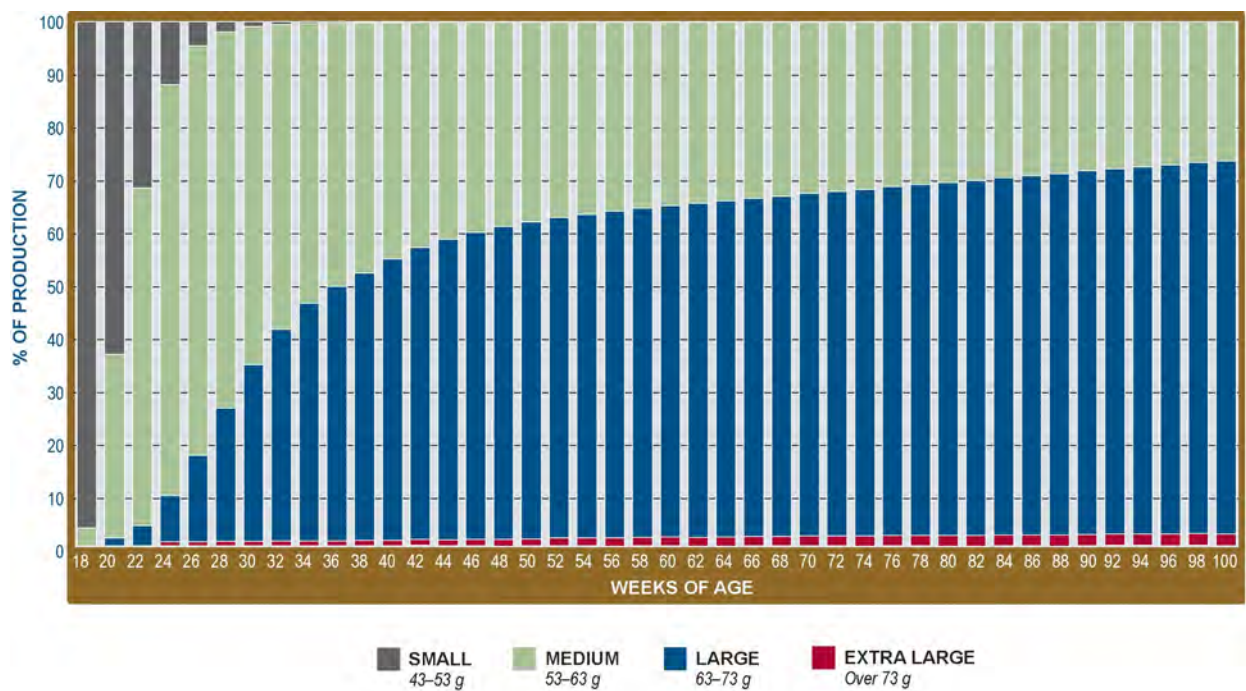

AGE (weeks)	AVERAGE EGG WEIGHT (g)	WEEKLY % SMALL 43-53 g	WEEKLY % MEDIUM 53-63 g	WEEKLY % LARGE 63-73 g	WEEKLY % VERY LARGE Over 73 g
18	46.5	96.6	3.4	0.0	0.0
20	51.6	63.5	35.0	1.5	0.0
22	55.0	31.7	64.4	3.9	0.0
24	57.5	12.0	78.4	8.8	0.8
26	59.2	4.6	78.1	16.5	0.8
28	60.4	2.0	71.7	25.4	0.9
30	61.3	1.0	64.4	33.7	0.9
32	62.0	0.6	58.1	40.3	1.0
34	62.5	0.4	53.3	45.3	1.0
36	62.9	0.3	50.2	48.5	1.0
38	63.2	0.2	47.8	50.9	1.1
40	63.4	0.2	45.1	53.6	1.1
42	63.6	0.1	43.0	55.6	1.2
44	63.8	0.1	41.4	57.3	1.2
46	63.9	0.1	40.1	58.5	1.3
48	64.0	0.1	39.0	59.6	1.4
50	64.1	0.1	38.1	60.4	1.4
52	64.2	0.1	37.3	61.1	1.5
54	64.3	0.1	36.7	61.7	1.5
56	64.4	0.1	36.1	62.3	1.6
58	64.4	0.1	35.5	62.8	1.6
60	64.5	0.1	35.0	63.2	1.7
62	64.6	0.1	34.6	63.7	1.7
64	64.6	0.1	34.1	64.1	1.8
66	64.7	0.1	33.6	64.5	1.8
68	64.7	0.1	33.2	64.9	1.8
70	64.8	0.1	32.7	65.3	1.9
72	64.9	0.1	32.3	65.7	1.9
74	64.9	0.1	31.9	66.1	2.0
76	64.9	0.1	31.4	66.5	2.0
78	65.0	0.1	31.0	66.9	2.0
80	65.0	0.1	30.6	67.3	2.1
82	65.1	0.1	30.2	67.7	2.1
84	65.1	0.1	29.7	68.1	2.1
86	65.2	0.1	29.3	68.5	2.1
88	65.2	0.1	28.9	68.9	2.2
90	65.3	0.0	28.5	69.3	2.2
92	65.3	0.0	28.1	69.6	2.2
94	65.3	0.0	27.7	70.0	2.2
96	65.4	0.0	27.3	70.4	2.3
98	65.4	0.0	26.9	70.7	2.3
100	65.5	0.0	26.6	71.1	2.3

* Distribution of egg sizes based on weekly (not cumulative) average egg weights.

Metrics of Flock Performance

Growth & Development

- **Weekly Flock Body Weight (g):** Average bird weight of a 100-bird sample
- **Flock Uniformity %** (see [Uniformity Calculation Tool](#)): $[(\text{Total number of birds weighed}) - (\text{Number of birds} \leq 10\% \text{ of average body weight}) - (\text{Number of birds} \geq 10\% \text{ of average body weight})] / (\text{Total number of birds weighed})$
- **Coefficient of Variation (CV) %** (see [Uniformity Calculation Tool](#)): $\text{Standard deviation of 100-bird sample} / (\text{Average bird weight of same sample})$
- **Weekly Weight Gain (g):** $(\text{Average body weight at end of the week}) - (\text{Average body weight for previous week})$
- **Feed Efficiency of Body Weight Gain:** $(\text{Total feed consumed} / \text{Number of birds in the flock}) / \text{Average weight gained}$
- **Body Score** (see [Body Score Chart](#)): Average body score of a 100-bird sample

Liveability (Mortality)

- **Daily Mortality:** $(\text{Total dead birds for the day}) / (\text{birds day})$
- **Weekly Mortality:** $(\text{Total dead birds for the week}) / (\text{birds @ start of week})$
- **Cumulative Mortality:** $(\text{Total dead birds to date}) / (\text{birds housed})$

Egg Production

- **Percent Hen-Day Egg Production (HD%):** $(\text{Number of eggs produced in one day}) / (\text{Current hen inventory})$
- **Hen-Housed Egg Production (HH%):** $(\text{Number of eggs produced in one day}) / (\text{Hens housed})$
- **Weekly Egg Mass (EM) (kg):** $(\text{Weekly hen-housed percent}) \times (\text{Average egg weight in g}) / 1,000$
- **Cumulative Egg Mass (HHEM) (kg):** Sum of weekly egg mass

Egg Production Efficiency

- **Feed Conversion Rate:** Kg of feed consumed during the period / Kg of egg mass produced during the period
- **Feed Utilisation:** Kg of egg mass produced during the period / Kg of feed consumed during the period
- **Feed Consumption per 10 Eggs (kg):** (Kg of feed consumed / Total number of eggs produced) x 10

Facility Cleaning & Disinfection

Facility Preparations Before Chick Delivery

- The optimal downtime between flocks is 4 weeks. At least 2 weeks downtime is strongly recommended to allow for sufficient cleaning and disinfection.
- Clean and disinfect brooding areas, building interior, attached service areas, and equipment.
- All feed and manure should be removed from the facility before cleaning.
- Clean and disinfect feeding system, allowing it to dry before new feed is delivered.
- Wash the upper portion of the facility and work downward toward the floor.
- Thoroughly clean air inlets, fan housing, fan blades and fan louvers.
- Heating the facility during washing improves the removal of organic matter.
- Use foam/gel disinfection/detergent to soak into organic matter and equipment.
- Use high pressure warm water to rinse.
- Allow the facility to dry. After it is fully dry, apply foam/spray disinfectant followed by fumigation.
- Place rodent bait where it will not be consumed by chicks.
- Confirm effectiveness of cleaning and disinfection with environmental swabs.
- For more information, see **Pre-Housing Cleaning, Disinfection and Maintenance Checklist for Rearing and Layer Facilities.**

Chick Management

Hy-Line Brown chicks adapt well to intensive cage system brooding environments. Hatchery services/treatments are performed as requested by the customer. For more information, see **Growing Management of Commercial Pullets**.

One Day Before Chick Delivery

- Pre-heat the brooding facility prior to chick delivery: 24 hours in normal or warm climates, 48 hours in cool climates and 72 hours in cold climates. The facility should be at proper brooding temperature at minimum for several hours before the arrival of the chicks.
- Establish proper facility temperature of 33–36°C and 60% humidity (measured at chick level).
- Bright light (30–50 lux) during 0–7 days helps chicks quickly find feed and water and adapt to the new environment.
- Floor temperature should be 32°C at the time of chick placement.
- Check water system and adjust to the correct height for chicks. The first day nipple lines can be placed low to encourage rapid discovery by chicks. On day 2 they should be adjusted to the correct height to maintain the best water access and litter conditions.
- Sanitise and flush water lines.
- Check to make sure equipment is working properly and is adjusted to the correct height.
- Check the lighting system and confirm correct light intensity.

Day of Chick Delivery

- Check that facility temperatures are appropriate for brooding chicks.
- When using nipple drinkers, adjust the water pressure to ensure there is a droplet of water visible on the nipple.
- Place supplementary feed onto papers or trays.
- Fill feeders to their highest feed level, allowing easy access for the chicks.
- Lights should be adjusted to provide a minimum light intensity of 30 lux for the first week.

Transportation from Hatchery to the Farm

- Use a truck designed for transportation of chicks.
- Truck should be environmentally controlled, maintaining 26–29°C at 70% relative humidity (measured inside chick box); with a minimum air flow of 0.7 m³ per minute.
- Provide space between stacks of chick boxes for air flow.

Chick Placement

- Brood chicks in groups of similar aged breeder flocks when possible.
- Unload chick boxes quickly and gently place the chicks in the brooding area.
- As chicks are placed, trigger water cups or nipples to encourage drinking.

Brooding Recommendations

The brooding period (0–14 days) of the pullet's life is critical. The digestive and immune systems develop during this time. Good management during this period assures that the pullet gets off to a good start toward reaching her genetic potential.

Water

- Drinking water should be tested for quality and cleanliness from source and end of the water line.
- Trip nipples 3x per day for the first 3 days.
- Flush water lines prior to chick arrival.
- Maintain water temperature of 20–25°C during brooding period.
- Do not give cold water to chicks. Be careful when flushing water lines for chicks. Allow water time to warm up in the facility so chicks are comfortable drinking.
- Flush water lines at night to limit chicks' exposure to cold drinking water.
- Clean supplemental chick drinkers daily to avoid build-up of organic matter that could encourage bacterial growth.

- Use a ratio of 80 chicks/circular drinker (25 cm diameter).
- Use a ratio of one nipple/cup per 12 birds for the first three weeks.
- Chicks should not need to move more than 1 metre to find feed or water.
- Use vitamins and electrolytes in chicks' drinking water (avoid sugar-based products to prevent growth of microorganisms).

Lights

- Bright light (30–50 lux) during 0–7 days helps chicks find feed and water and adapt to the facility environment. Ensure that the light (measured at the level of the water nipple) is uniform in the brooding area. Avoid shadows and dark areas.
- An intermittent lighting programme for chicks is strongly preferred. If not using an intermittent lighting programme, use 20 hours of light and 4 hours of dark for 0–7 days.
- Do not use 24 hours of light. Birds require a dark period to grow properly.
- After the first week, reduce light intensity and begin slow step-down lighting programme (see Light Programme for Light Controlled Housing).

Cage Brooding Systems

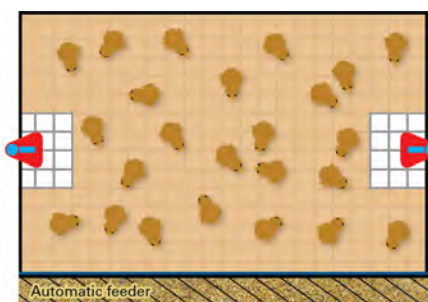

CORRECT: Chicks evenly distributed in cage, active and sounding content.

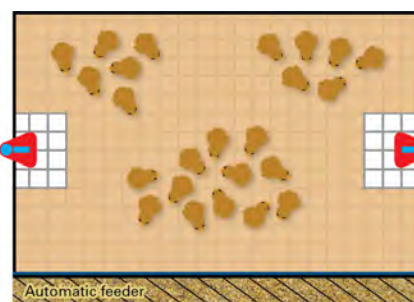

COLD: Chicks gathered into groups, sounding distressed.

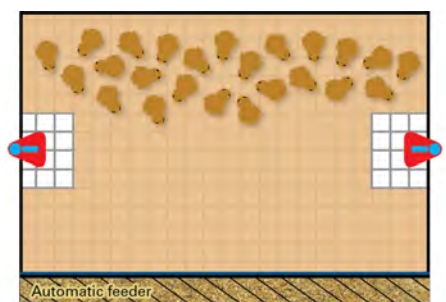

UNEVEN VENTILATION: Chicks congregated in one part of cage, avoiding drafts, noise, or uneven light distribution.

Cage Brooding Systems

Paper

- Cover entire cage floor with paper. Place feed on paper close to the feeder.
- Place crumb starter feed on paper for 0–3 days. For beak-treated chicks, feed on paper for 0–7 days.
- If using a vaccine for coccidia, feed on paper for 14 days. After 14 days, either keep 1/4 of the paper or add a fibre tray to allow for coccidial vaccine cycling until 28 days of age.
- Remove paper between 7–14 days to avoid the build-up of manure.

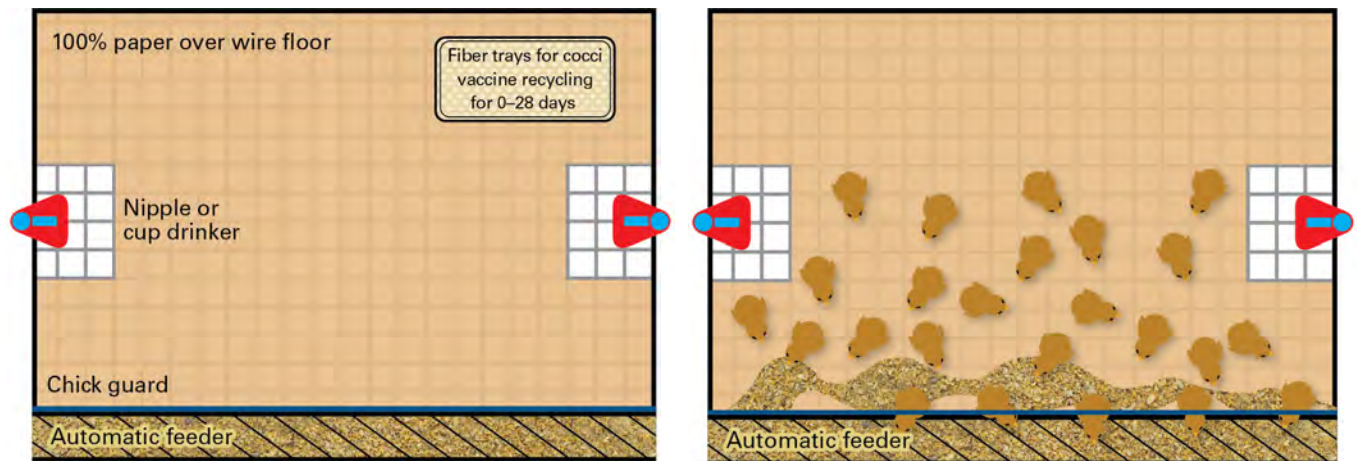

Chick guard adjusted to allow access to feeder from first day.

Place feed on paper near automatic feeder to train chicks.

Ring and Partial Facility Brooding Systems

Paper

- Cover entire floor of brooder ring with paper. In partial facility brooding, feed on the paper near the permanent feeders.
- Place crumble starter feed on paper for 0–3 days. For beak-treated chicks, feed on paper for the first 7 days.
- If using a vaccine for coccidia, keep paper or trays to allow for coccidial vaccine cycling until 28 days of age.

Tray Feeders

- Use a ratio of 80 chicks/tray feeder. Clean egg trays and box tops can also be used.
- Use good quality crumb starter feed consisting of uniform 1–2 mm particles.

Partial Facility (Floor) Brooding

- A section of the facility is partitioned and used for brooding.
- When using brooding stoves instead of whole facility heating, minimum facility air temperature during floor brooding is 30°C.
- Eliminate all drafts from the brooding facility.
- Spread litter after concrete floors have warmed.
- Gradually remove supplemental drinkers and tray feeders beginning at 3 days.

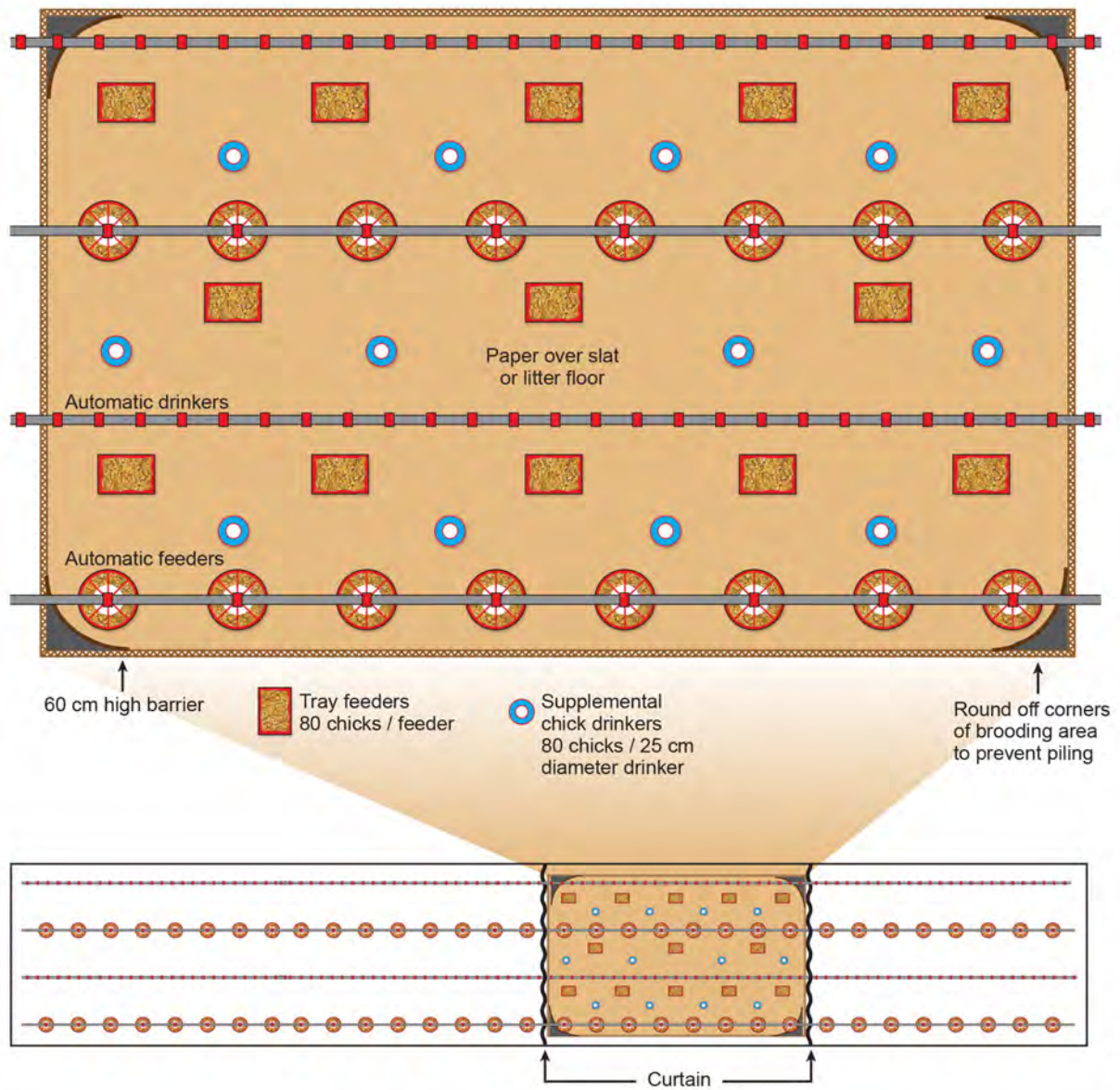

Brooder Rings

- Enlarge brooder rings at 3 days to increase group size.
- Continue enlarging brooder rings until all rings are removed by 14 days.
- Slowly remove supplemental drinkers and tray feeders beginning at 3 days.

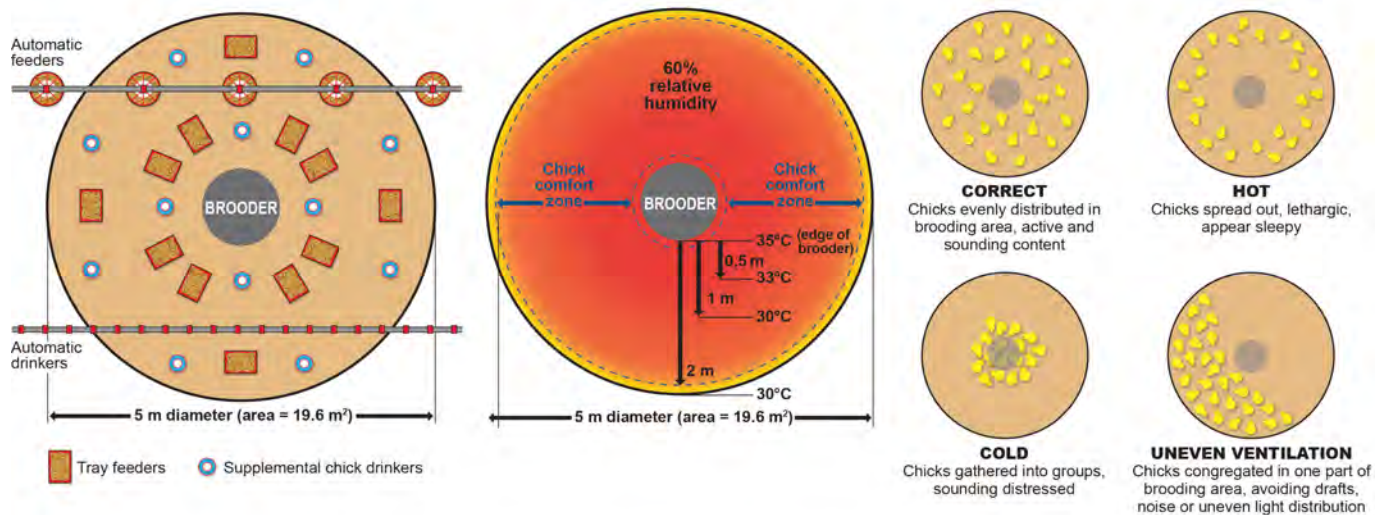

Brooding Temperature and Relative Humidity

- Find optimum balance of temperature, humidity, and ventilation rate for chick comfort.
- Chicks are unable to fully control body temperature during the first week of life and depend on proper environmental temperature.
- Adjust brooder temperatures according to relative humidity. Lower temperatures should be used with higher humidity. For every 5 percentage points above 60% relative humidity, reduce brooding temperature 1°C.
- Provide temperature zones within the brooding area accessible to the chicks. This allows birds to seek a comfort zone.
- After the first week, reduce temperature weekly 2–3°C until reaching 21°C.

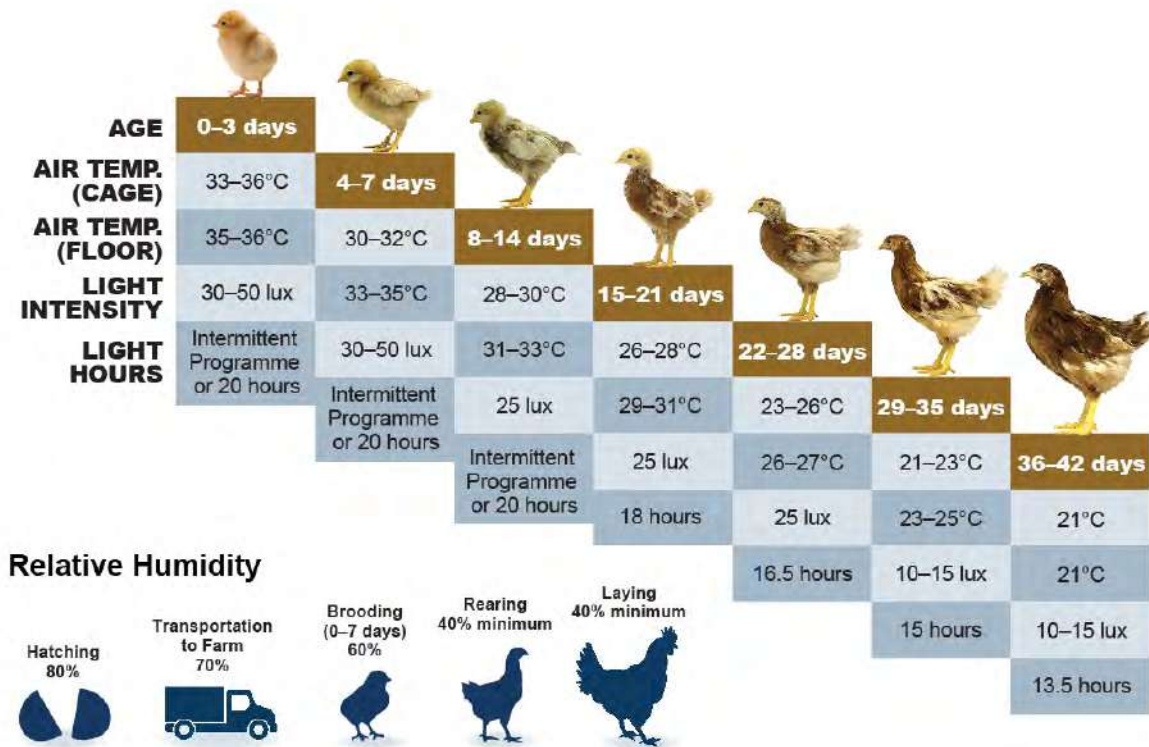

Low humidity

- Reduces bird comfort
- Increases dehydration
- May result in pasty vents in chicks
- May increase agitation and possibility of pecking
- Adversely affects feather cover
- Increases dust

Hours after chick placement	Chicks with feed in crop		
6	75%		
12	85%		
24	100%	Chick with starter feed in crop	Chick without starter feed in crop

Excessive humidity

- Increases ammonia
- Causes poor litter and air quality

Cloacal Temperature

- Target body temperature for chicks is 39.4–40.5°C.
- Measured using a digital infant ear thermometer by gentle insertion at the chick's vent.
- Cloacal temperature correlates well with the core body temperature.
- Cloacal temperature is an indicator of chick comfort and adequacy of the brooding environment.
- Chilling or overheating chicks during the brooding period can result in poor growth and increased susceptibility to disease.



An infant ear thermometer being used to measure the chick's body temperature via the vent.

Intermittent Lighting Programme for Chicks

- Preferred lighting technique.
- Use from 0–7 days (can be used up to 14 days of age).
- Intermittent dark periods provide rest periods for chicks.
- Synchronises chicks' activities and feedings.
- Establishes more natural behaviour of rest and activity.
- May improve 7-day liveability and pullet body weight.
- Some dark periods may be shortened or removed to accommodate work schedules.



Intermittent Lighting Programme for chicks

Infrared Beak Treatment (IRBT)

(Check local regulations concerning use of beak treatment)

- Infrared beak treatment has been proven a successful, non-invasive method of controlling the growth of the beak in egg type chickens.
- One (properly applied) IRBT should be sufficient.
- Hatchery beak treatment reduces feed wastage and leaves the beak less damaging to other birds.
- Hatchery beak treatment is more efficient and uniform than on-farm practices.
- The tip of the beak will wear off gradually between 10–21 days.
- Infrared treatment is adjustable to manage differences in breeder flock age, chick size, climate, and variety of birds.
- For more information, see [Infrared Beak Treatment](#).



Loading chick

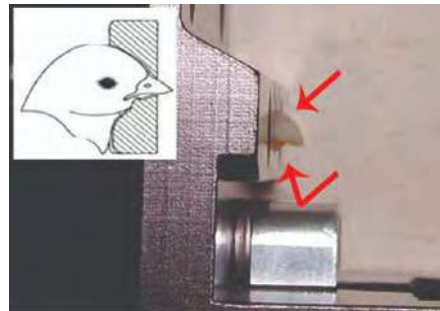

Infrared beak treatment can be modified according to local conditions.

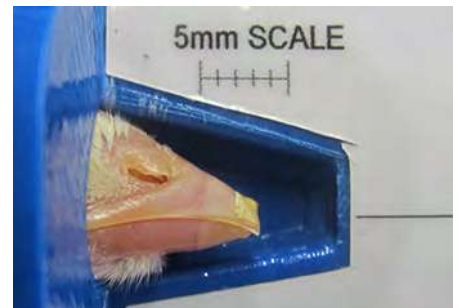

One day post-treatment

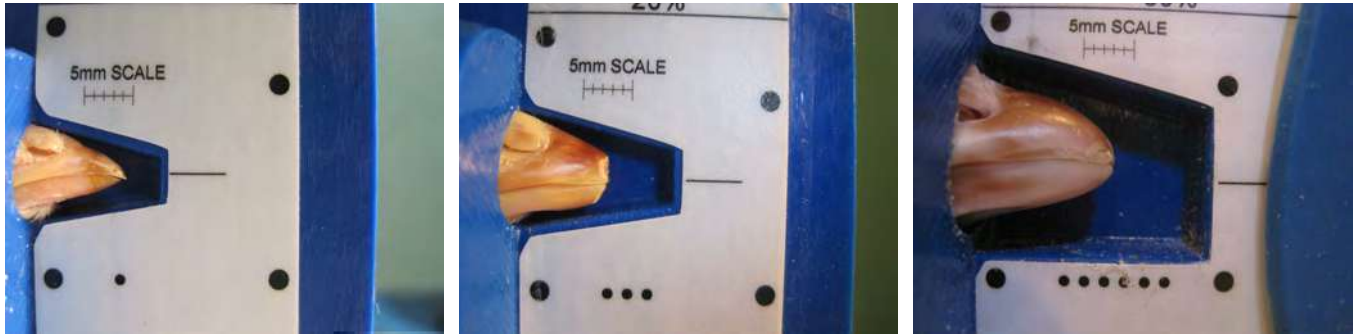

Seven days post-treatment

Four weeks post treatment

Properly trimmed beak

Additional care for successful IRBT chick starts:

- Water intake is the most important factor for success with IRBT chicks. Chicks require immediate and easy access to water.
- If using nipple drinkers, use only 360° activated nipples for IRBT chicks, as well as supplemental chick drinkers.
- Nipple drinkers with splash cups provide additional support for IRBT chicks.
- Keep feed at the highest level in the feeder for several days after beak treatment.
- Feed on paper for 0–7 days.
- Provide extra light (30–50 lux) on nipple drinkers after beak treatment.

Precision Beak Trimming

- Check local regulations concerning use of beak treatment.
- Cauterize beak for 2 seconds at 650°C.
- When cauterizing blade is not hot enough or cauterization time is < 2 seconds, beak will continue to grow unevenly.
- If cauterizing blade is too hot or cauterization time is > 2 seconds, sensitive neuromas may form.
- Use a pyrometer to measure blade temperature, which should be approximately 650°C.
- Cauterizing blade color may be used as an approximate indicator of temperature (see below).
- Blade temperature variation of up to 40°C is common due to external influences and cannot be detected by the human eye.
- Use a template with guide plate holes for precision beak trim of different size chicks.
- Check that beaks have been properly and evenly trimmed.

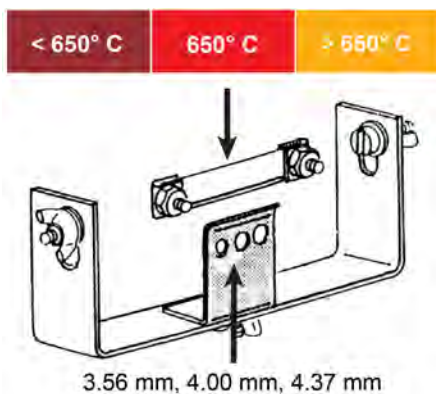

Cauterizing blade and template with guide holes of varying sizes.



Beak trimmer. Photo: Lyon Technologies, Inc.



Pyrometer indicating proper blade temperature of 650°C.





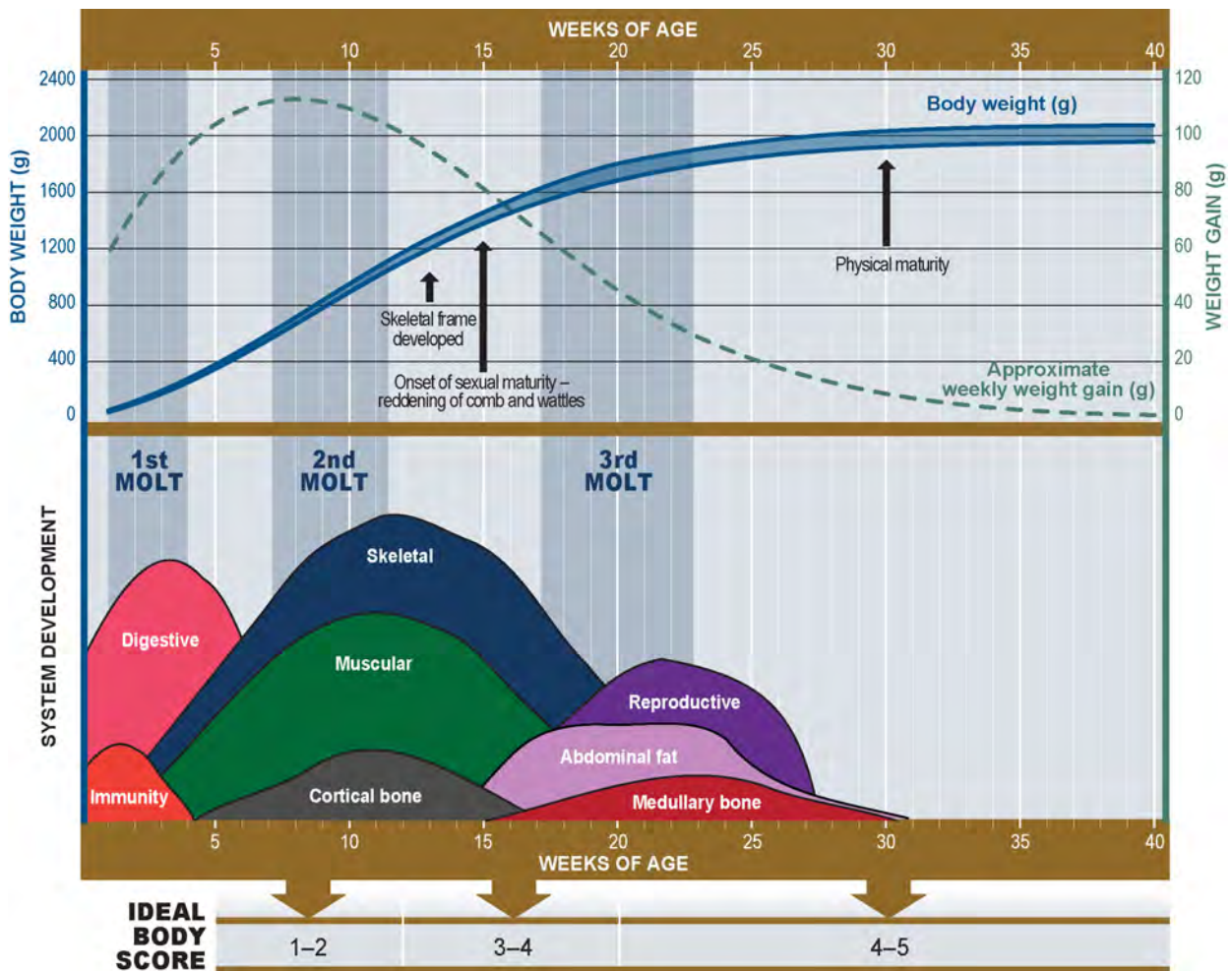

Precautions when beak trimming birds:

- Water intake is the most important factor in the success of beak trimming. Chicks require immediate and easy access to water.
- Do not beak-trim sick or stressed birds.
- Do not hurry; handle chicks carefully.
- Provide vitamins and electrolytes containing vitamin K in drinking water 2 days before and 2 days after beak trimming.
- Watch chicks after beak trimming to assess stress. Raise ambient temperature until birds appear comfortable and active.
- Keep feed at the highest level for several days after beak trimming.
- Use only well-trained crews.
- Use 360° activated nipples, supplemental chick drinkers, and splash cups to encourage drinking.

Development of the Organ Systems in Pullets



Body Score Chart

	0	1	2	3	4	5	6
Sternum (Keel)							
Abdominal Fat	None	None	None	None	< 0.7 cm	> 0.7 cm	Large fat pad
Comments	Emaciated birds	Low level of breast flesh concave in shape	Moderate breast flesh pyramid in shape	Well fleshed breast convex in shape	Abdominal fat pad small; Breast convex in shape	Abdominal fat pad increasing in size; Breast convex in shape	Pendulous fat pad; Breast convex in shape

Scores of 4 and 5 are ideal for pullets at the beginning of egg production.

Monitoring Flock Body Weights & Uniformity

Uniformity

- The uniformity of body weights within a flock is an indicator of flock development.
- Prior to point of lay, flocks should have a minimum uniformity of 85%.
- Uniformity of body weights makes accurate feeding and management of the flock easier.
- Body weight gains and uniformity may be negatively affected by bird handling, vaccination, transfer, and disease outbreak.
- Multiple hatch dates complicate lighting, feeding, and vaccination programs.



Weigh birds separately after 3 weeks using a digital scale that calculates uniformity.



3-week-old pullets from the same flock with very different development show the importance of monitoring flock body weight uniformity.

Calculation of Uniformity

- For the formula to calculate flock uniformity, see Metrics of Flock Performance. A **Uniformity Calculation Tool** is also available.
- The second way of expressing uniformity is the percentage of birds within +/- 10% of the average weight.
- A desirable goal is for 85% of birds to fall within $\pm 10\%$ of the average weight. For example, if a flock average weight at 18 weeks is 1470 g, 85% of all birds should weigh between 1323 g and 1617 g.
- While this method gives an accurate indication of the number of birds close to the average, it does not (unlike CV%) take into account very light and heavy birds.
- One method of calculation should be used consistently throughout the rearing period, because the numerical result obtained will differ slightly depending on the method used.

CV%	Uniformity (+/- 10% of average)
5	95.4
6	90.4
7	84.7
8	78.8
9	73.3
10	68.3
11	63.7
12	58.2
13	55.8
14	52.0
15	49.5
16	46.8

Normal Distribution of Body Weights

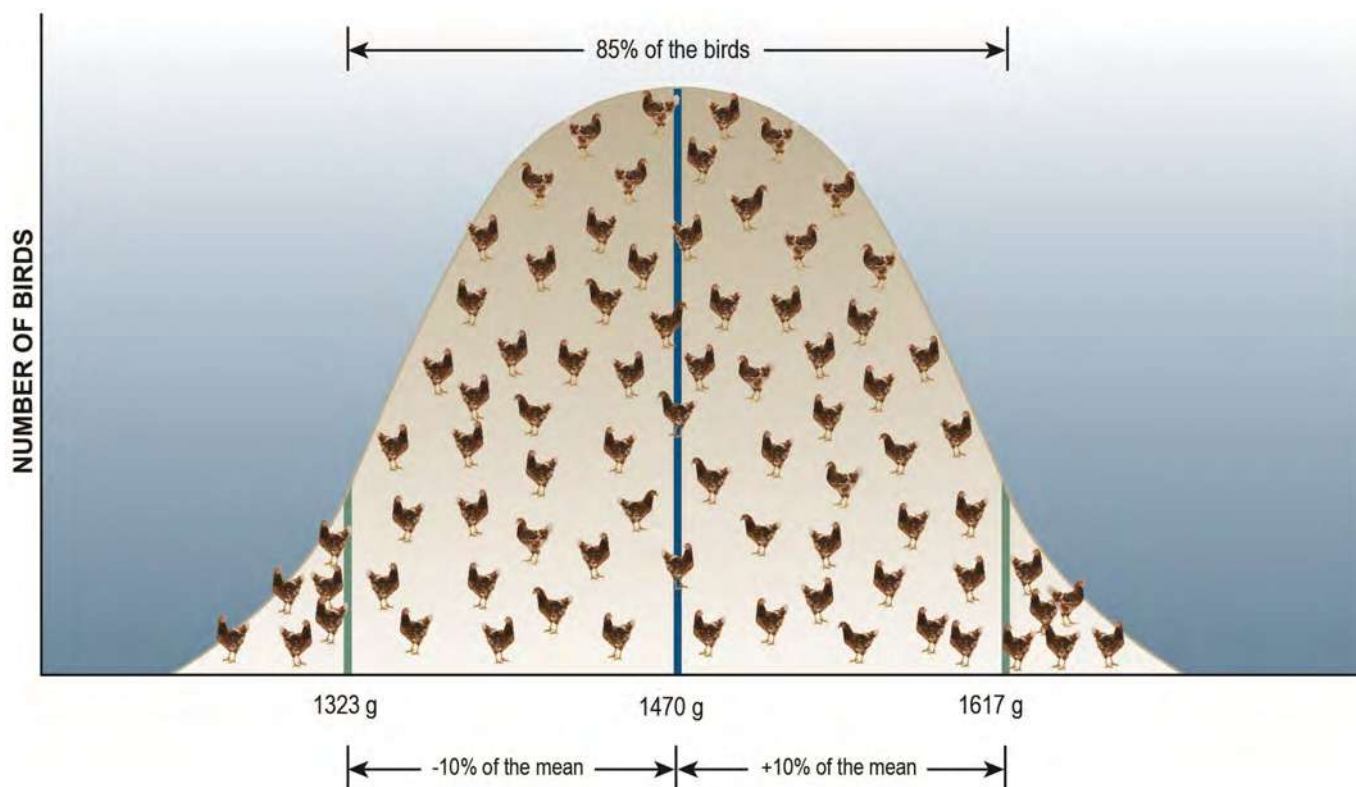

Record individual body weights to ensure a bell-shaped or “normal” distribution.

Growth & Development Tips

- The design of the rearing facility should closely match that of the layer facility to which the flock will be transferred. Drinker type and feeder type should be the same. When the rearing feed, water, and facility design do not match the production facility, the birds may be slower to adjust to their new environment. These changes result in more stress on the birds, which in turn can affect production in various forms.
- Chicks’ body weight should double between arrival and 7 days of age and reach 10x the chick weight by 5 weeks.
- It is important to achieve 6, 12, 18, 24, and 30 week body weight targets to ensure optimum development of the bird’s body.

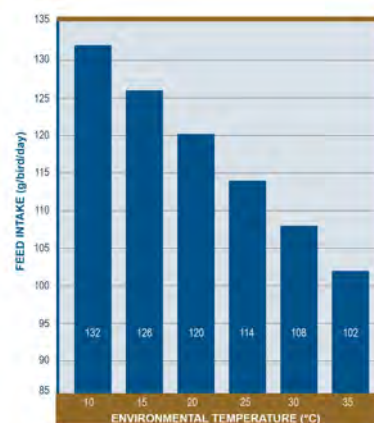

Approximate relationship between feed intake and environmental temperature.

- If possible, aim for the high end of the pullet body weight standards throughout rear, but take care not to exceed the high end by more than 5%. Obese birds may have greater mortality post peak from fatty liver hemorrhagic syndrome. For more information, see **Fatty Liver Hemorrhagic Syndrome**.
- Use a crumb starter feed to promote good feed intake and uniform nutrient intake.
- Change rearing diets only when the recommended body weight with good uniformity (> 85%) is attained. Delay diet change if birds are underweight or have poor body weight uniformity.
- Changing diets based on age can result in poor uniformity or overweight flocks.
- By 12 weeks of age, match the feeding schedule to what will be used in the production facility.
- During the rearing period, run feeders 3–5 times per day. Feed more frequently to encourage feed intake in underweight flocks or in hot weather. In the case of hot weather, avoid feeding the birds during the hottest times of the day and instead allow this time to be “clean up” of the fines or other sorted particles in the feeders. Manage feeders so that additional feedings do not create excessive fine feed particles. Check feed consumption against the body weight/feed consumption table at right. See Feeding Schedules in Nutrition section.
- Anticipate rapid rise in ambient temperature during summer and adjust bird’s diet accordingly. Birds will eat less when exposed to a rapid temperature increase.
- Delay diet changes until after a stress-inducing event, such as catching birds for an injected vaccination.

Transition Period from Rear to Peak Egg Production

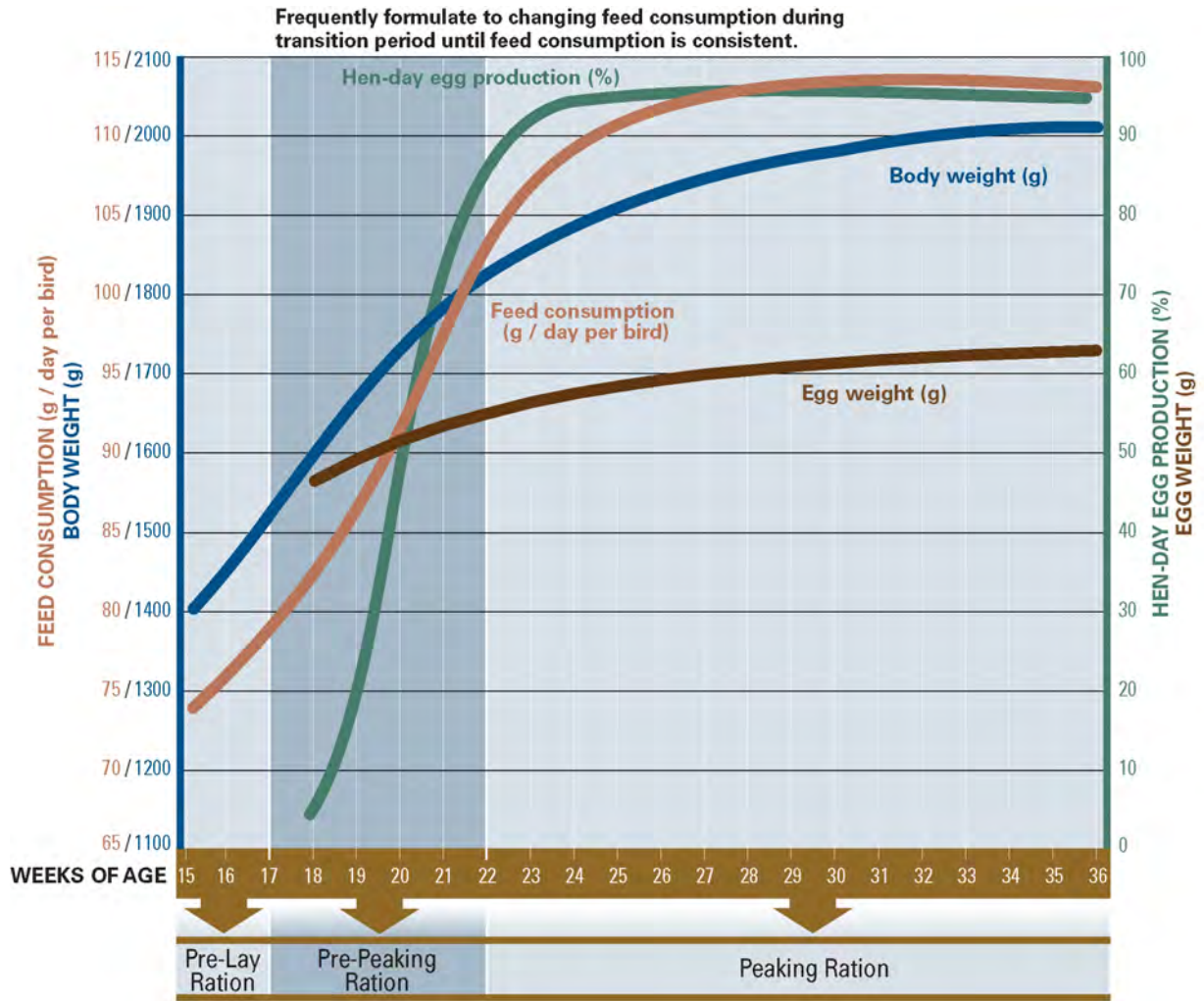

- Avoid excessive weight gain during the transition period.
- Body weight gain from 18–25 weeks should not exceed 20%. If you have a 1.59 kg bird at 18 weeks, the goal should be to stay under 1.91 kg by 25 weeks, otherwise there is a risk of fatty liver.
- During the transition period, nutrient requirements increase dramatically and diets should be adjusted to accommodate this phase. See Pre-Peak Diet in Nutrition section.
- The following occurs during the transition period:
 - Rapidly increasing egg production
 - Increasing egg size
 - Increasing body weight
- Feed consumption may increase slowly during transition:
 - In underweight flocks
 - In flocks lacking uniformity
 - During high environmental temperatures
- Poor uniformity prolongs the transition period and may result in delayed onset of egg production, low production peaks, and poor persistency of egg production.
- It is essential to monitor feed intake carefully during transition and adjust dietary nutrient concentration according to actual feed intakes.

Transfer Management

- Ensure birds are moved with welfare as a priority.
- Birds should be transferred to the lay facility a minimum of 14 days before the first egg. Transfer typically occurs between 14–16 weeks of age.
- Earlier transfer makes it easier for birds to adapt to their new laying environment prior to the onset of egg production.
- Two weeks prior to moving, gradually increase light intensity in the rearing facility to match the production facility.
- Light hours of rearing and production facility should be matched at transfer.
- Three days before moving pullets to the laying facility, begin using water-soluble vitamins and electrolytes in the drinking water to relieve stress.
- Transfer birds quickly to laying facility and transfer all birds on the same day. Move early in the morning so birds can keep to a normal daily routine and weather is cooler.
- Water consumption during the last week on the rearing farm should be noted and compared with water consumption in the laying facility immediately after transfer. The time taken to match the previous level of water consumption and subsequently exceed it will be an indication of how well the birds have adapted to their new environment. Birds should be drinking normally by 6 hours after transfer.
- Keep nipple drinkers lowered after transfer to slightly above the bird's back before raising them to head level for the first week.
- If piling of birds at the facility is a problem, leave lights on at night for the 2–3 nights after transfer to reduce the risk of birds piling. Check local regulations.
- Increase light intensity for first 2–3 days to help birds adapt to their new environment.
- Facility temperature at transfer of 15–20°C will encourage feed intake.
- Before transfer, the flock should have resistance against coccidia by the use of coccidiostats in the feed or by vaccination early in life.

Bird Handling Welfare

- Proper handling of birds during body weight measurement, blood collection, selection, vaccination, and transfer will reduce bird stress and prevent injuries.
- Hold birds by both legs or both wings.
- Return birds to cage gently.
- Use experienced personnel that have been trained in proper procedures of bird handling.
- Continually observe crews for proper handling.
- Hold no more than three birds in one hand.



Holding the bird by both legs.



Holding the bird by both wings.



Birds should be supported with both hands as hen is moved into or out of cages.

Body Weight Loss of Birds in Transit

- Weigh prior to transfer and monitor weight loss during transfer.
- It should be noted that at the time of transfer from rearing to production houses, there will be some loss in body weight (which is normally 10–12%). This loss is mainly due to reduced water intake and some dehydration of the pullet.
- To help regain these losses, the following factors should be considered.
 - Age of transfer (earlier transfers are less stressful).
 - Good availability of fresh, potable water, monitoring intake levels to ensure good uptake.
 - Good availability of fresh feed, similar in physical quality and nutrient profile to the feed used in the rearing house just before transfer.
- Match lighting programmes between rearing and production houses.
- Match drinker and feeder type between rearing and production.
- Care must be taken in hot or cold ambient conditions to maintain an appropriate house temperature.

Conditioning the Pullet for Egg Production

Pullet conditioning are those management programmes used to prepare the pullets for the smooth, low-stress transfer to the laying facility and for the commencement of egg production.

Management Tips for Effective Pullet Conditioning

Facility			
Factor	Practice	Result	Tips
Drinker and feeder systems; elevated water tables	Drinker and feeder type should be matched in the rearing and production facility.	Smoother, low stress transition from rearing to production.	The configuration of drinking and feeder lines should be similar in rear and production facilities.
Lighting Program			
For more information, see Lighting Programs section.			
Factor	Practice	Result	Tips
Light intensity	Two weeks prior to transfer increase the light intensity in the rearing facility. This increase prepares the pullets for transfer to the laying facility.	Prepares pullets for transfer to the laying facility and for light stimulation after transfer.	By transfer, the number of light hours and light intensity should be matched with the lights in the production facility.
Time of light stimulation	Provide light stimulation when the pullet flock reaches their target average body weight with >85% uniformity.	Improves flock uniformity. Uniform flocks respond more evenly to light stimulation and higher consumption of Pre-Peak and Peaking diets.	Underweight pullet flocks or with <80% uniformity should delay light stimulation. If the pullet flock has a large spread in hatch ages and/or poor bodyweight uniformity, then light stimulation is based on the youngest hatch date or lightest birds.
Bird Behavior			
For more information, see Understanding Nesting Behavior and Managing Fully Beaked Flocks .			
Factor	Practice	Result	Tips
Accustom the pullets to noise, color and human presence	Playing music, walking in the flock frequently and changing the color of the workers clothes can help acclimate the birds.	Desensitizes the birds to these stimuli resulting in less fear responses and behavior problems.	Make noise while walking in pullet flocks.

Nutrition			
For more information, see Nutrition section.			
Factor	Practice	Result	Tips
Feeding schedule	Match the feeding schedules used in rear and the production period.	Smoother, low stress transition from rearing to production. Improves feed consumption in young laying flocks.	
Feed presentation and feed particle size	Feed presentation (i.e. mash or pellet) should be the same in rearing and production diets.	Improves feed consumption in young layer flocks.	Manage feeders to avoid accumulation of fine feed particles.
Large particle calcium	Introduce large particle calcium beginning in the Pre-Lay diet.	Builds medullary bone in pullet flocks. Early introduction of larger calcium particles will ease the transition to consuming Pre-peak and Peaking diets.	
Higher fiber in pullet feed	Beginning in the Developer diet increase the amount of fiber.	Improve digestive tract development. Increases feed intake at the commencement of egg production.	Higher fiber diets increase feeding time and reduce feather pecking behavior.
Transfer to the Laying Facility			
Factor	Practice	Result	Tips
Age of transfer	Transfer flocks on time to prevent overcrowding in the rearing cages.	Late transfer may restrict feed, water and living space and could result in loss of pullet body condition.	Transfer flocks by 16 weeks to allow time to acclimate to the new laying environment.
Vaccination Program			
For more information, see Vaccination Recommendations .			
Factor	Practice	Result	Tips
Pullet vaccination program	Avoid a stressful vaccination just before the transfer.	May result in loss of pullet body condition.	Design vaccination program to minimize the number times birds are handled.
Heat Stress Tolerance			
For more information, see Managing Heat Stress in Layers .			
Factor	Practice	Result	Tips
Heat stress tolerance	Exposure of pullets to high environmental temperatures.	Results in production of heat shock proteins which can mitigate future heat stress.	

Record Keeping for Flock Performance

Suggested Record Keeping for Flock Performance

Daily:

- Number dead and culled
- Egg collection details to give numbers of good, seconds and non-nest eggs amounting to a total daily production figure
- Maximum and minimum facility temperature
- Water intake
- Feed intake (if not daily, then weekly)

Weekly:

- Body weight and uniformity
- Average egg weight
- Feather score
- Hours of light
- Feed ration

Management Wheel

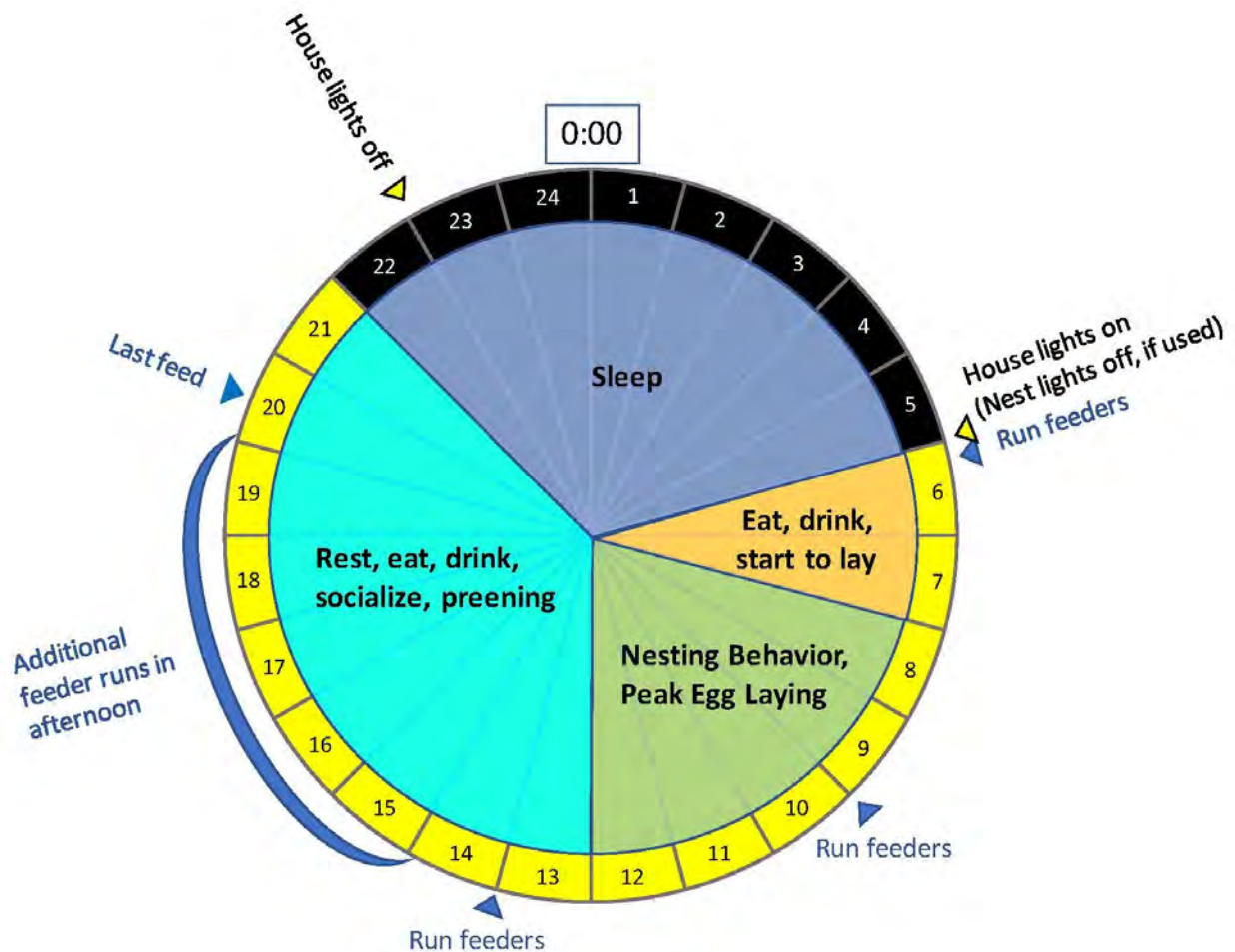

Enriched Colonies

- Enriched colonies address some of the welfare concerns of layers in cages by providing more space with environment enrichment devices, such as perches, nest boxes, scratch areas and abrasive pads for beak and toe shortening.
- Generally, bird group sizes range from 40–110 birds per cage.
- As group size increases, there is more competition for feed and water space and less stable social groups. This could lead to behavioral problems like feather pecking and piling. Cage enrichments help prevent these behavioral problems.

Molting

In some situations, the Hy-Line Brown may be molted to rejuvenate egg production, shell quality, Haugh units, and feather cover. For molting the Hy-Line Brown, follow the guidelines given in **Non-Fasting Molt Recommendations**.

Water

Drinking Systems

- The type of drinkers used during rearing should be the same as in the production facility. Use the same nipple type in rearing and production facility (vertical vs. 360° activated nipples). In general, 360° activated nipples are recommended, especially for IRBT flocks.
- Ensure that palatable water is available to the birds at all times. Water should be kept fresh and clean by flushing water lines weekly during rearing and production periods. Flush water lines during the night, before lights come on in the morning.
- Record daily flock water consumption. A drop in water consumption is often the first sign of a serious problem in the flock.
- Regular water treatment with a bird-safe sanitiser is recommended.

Nipple Drinkers

- Nipple drinking systems are preferred because they are a closed system and more sanitary.
- Adjust nipple water system pressure to create a hanging drop to help chicks find water for 0–3 days and in layer facility at transfer for 7 days. Seeing a hanging drop after the first 7 days is an indication that the water pressure is too low and should be adjusted to the appropriate level for the age of the flock.
- Splash cups are useful during brooding period and in hot climates.
- 360° activated nipples make drinking easy for chicks.
- Use only 360° activated nipples for IRBT chicks, as well as supplemental chick drinkers.
- Nipple drinkers should deliver a minimum 60 ml per minute / nipple in adult layers, although this may change based on the water line manufacturer.
- Production facilities should be at 18–25°C and 40–60% humidity.

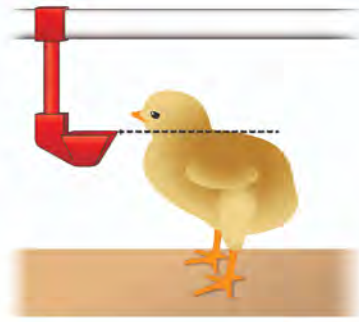

Cup or bell drinkers should be level with the chick's back.



Nipple drinkers should be level with the chick's head.



Nipple drinkers should be adjusted to the proper height, allowing easy intake of water.

- Good quality water must be available to birds at all times.
- Water and feed consumption are directly related—when birds drink less, they consume less feed and production quickly declines.
- As a general rule, healthy birds will consume 1.5–2.0 times more water than feed. This ratio will increase in high ambient temperatures.
- Test water quality at least once per year. The water source will determine the regularity of water testing.
- Drinking water should be tested periodically for quality and cleanliness by taking two samples: one from the water source prior to entering the poultry facility and a second sample from the end of the water line. Testing water from the source is a measure of bacterial load coming into the farm and should be managed by addressing the water source directly. Testing at the end of the line and comparing to the water source value is a measure of how effective the line cleaning has been and the current status of the water birds are drinking.
- When collecting a well water sample, let the water run for 2 minutes prior to collecting the sample. Water samples should be kept below 10°C and submitted to the lab in less than 24 hours.
- Surface water requires more frequent testing, as it is more affected by season and rainfall patterns.
- Closed wells taking water from aquifers or deep artesian basins will be more consistent in water quality but are generally higher in dissolved mineral content.
- The presence of coliform bacteria is an indicator that the water source has been contaminated with animal or human waste.
- Some water sources contain high levels of dissolved minerals such as calcium, sodium and magnesium. When this occurs, amounts of these minerals in water have to be considered when formulating feed.

- Preferable drinking water temperature for chicks is 20–25°C and for layers is 15–20°C.
- Ideal water pH is 5–7 to promote good water sanitation, increase feed consumption, and improve upper gastrointestinal health.
- Less than optimum water quality can have a significant impact on intestinal health which will lead to poor utilisation of nutrients in feed.

ITEM	MAXIMUM CONCENTRATION (ppm or mg/L)*	
Nitrate NO ₃ ⁻ ¹	25	Older birds will tolerate higher levels up to 20 ppm. Stressed or disease challenged birds may be more sensitive to effects of Nitrate.
Nitrate Nitrogen (NO ₃ -N) ¹	6	
Nitrite NO ₂ ⁻ ¹	4	Nitrite is considerably more toxic than Nitrate, especially for young birds, where 1 ppm Nitrite may be considered toxic.
Nitrite Nitrogen (NO ₂ -N) ¹	1	
Total dissolved solids ²	1000	Levels up to 3000 ppm may not affect performance but could increase manure moisture.
Chloride (Cl ⁻) ¹	250	Levels as low as 14 mg may be problematic if sodium is higher than 50 ppm.
Sulphate (SO ₄) ¹	250	Higher levels may be laxative.
Iron (Fe) ¹	<0.3	Higher levels result in bad odour and taste.
Magnesium (Mg) ¹	125	Higher levels may be laxative. Levels above 50 ppm may be problematic if sulphate levels are high.
Potassium (K) ²	20	Higher levels may be acceptable depending on sodium level, alkalinity, and pH.
Sodium (Na) ^{1,2}	50	Higher concentration is acceptable but concentrations above 50 ppm should be avoided if high levels of chloride, sulphate, or potassium exist.
Manganese (Mn) ³	0.05	Higher levels may be laxative.
Arsenic (As) ²	0.5	
Fluoride (F ⁻) ²	2	
Aluminium (Al) ²	5	
Boron (B) ²	5	
Cadmium (Cd) ²	0.02	
Cobalt (Co) ²	1	
Copper (Cu) ¹	0.6	Higher levels result in bitter taste.
Lead (Pb) ¹	0.02	Higher levels are toxic.
Mercury (Hg) ²	0.003	Higher levels are toxic.
Zinc (Zn) ¹	1.5	Higher levels are toxic.
pH ¹	6.3–7.5	Birds may adapt to lower pH. Below pH 5 may reduce water intake and corrode metal fittings. Above pH 8 may reduce intake and reduce effectiveness of water sanitation.
Total bacteria counts ³	1000 CFU/ml	This is likely to indicate dirty water.
Total Coliform bacteria ³	50 CFU/ml	
Faecal Coliform bacteria ³	0 CFU/ml	
Oxygen Reduction Potential (ORP) ³	650–750 mEq	The ORP range at which 2–4 ppm of free chlorine will effectively sanitise water at a favourable pH range of 5–7.

* Limits may be lower as interactions exist between magnesium and sulphate; and between sodium, potassium, chloride, and sulphate.

¹ Carter & Sneed, 1996. Drinking Water Quality for Poultry, Poultry Science and Technology Guide, North Carolina State University Poultry Extension Service, Guide no. 42

² Marx and Jaikaran, 2007. Water Analysis Interpretation. Agri-Facts, Alberta Ag-Info Centre. Refer to <http://www.agric.gov.ab.ca/app84/rwqit> for online Water Analysis Tool

³ Watkins, 2008. Water: Identifying and Correcting Challenges. Avian Advice 10(3): 10–15 University of Arkansas Cooperative Extension Service, Fayetteville

Air

- Production facility should be at 18–25°C and 40–60% humidity.
- The general rule for determining required fan capacity—4 m³ of air movement/kilogram of body weight per hour.

°C	1	3	6	12	18	19+
32	360	540	1250	3000	7140	9340–12000
21	180	270	630	1500	3050	5100–6800
10	130	180	420	800	2240	3060–4250
0	75	136	289	540	1500	1020–1700
-12	75	110	210	400	600	700–1050
-23	75	110	210	400	600	700–850

Air Movement (m³ / hour per 1000 birds), per ambient temperature at various weeks of age.

Acknowledgment: Dr. Hongwei Xin, Professor.

- Ventilation is essential to:
 - Provide each bird with adequate supply of oxygen
 - Remove moisture from facility
 - Remove carbon dioxide produced by birds
 - Remove dust particles
 - Dilute aerosolised pathogenic organisms
- Positive pressure facilities where exhaust air is exiting through vents and popholes prevents cold damp air from entering the facility in winter and causing wet litter.
- In tunnel ventilated facilities, if birds are confined inside the facility due to hot or cold weather, ensure that the stocking densities are appropriate for bird confinement.
- Allowable levels of noxious gases at floor level in the facility are based on local regulations; however, the minimum standards are:
 - Ammonia (NH₃): < 25 ppm
 - Carbon dioxide (CO₂): < 5000 ppm
 - Carbon monoxide (CO): < 50 ppm (measured over 8 hours)

Temperature

Physiology of Thermoregulation

- Thermoregulation is the ability to control the body temperature. This function takes approximately 10 days after hatching to achieve in the developing pullet.
- There are two mechanisms for thermoregulation: behavioural thermoregulation and neural thermoregulation.
- **Behavioural** thermoregulation occurs in cold temperatures when the chicks will attempt to decrease surface area for heat loss by “hunching” or “huddling.” Chicks will often crowd in groups to further reduce temperature loss. This ability is readily available to chicks when they hatch.
- **Neural** thermoregulation is accomplished through temperature sensing in the nervous system and characterised by “shivering.” Neural thermoregulation may take up to four weeks to develop post hatch to the point where the chick can maintain body temperatures without supplemental heat.
- An important part of the chick thermoregulation process is the growth of feathers which they use to trap air, and thus heat, against the body.
- Thermal stress occurs when the birds are subjected to temperatures above or below their thermoneutral (comfortable) zone. In laying hens, the thermoneutral zone is considered generally to be between 18–25°C. At temperatures outside the thermoneutral zone, the bird has to expend energy to maintain normal body temperature and metabolic activities. This diverts energy and other nutrients away from growth and egg production, resulting in performance loss.
- Young chicks have difficulty regulating their body temperature until they are fully feathered. Cold or heat stress can lead to a suppression of the immune system and these flocks become very susceptible to disease. It is common to see pasting vents, poor feed intake, and increased mortality when young flocks are subjected to prolonged chilling, overheating, or several days of large temperature swings (> 4°C). Whenever possible, maintain flocks in a thermoneutral zone appropriate for their age.
- Periods of high environmental temperatures, often accompanied by high relative humidity, are common in the summer months. Heat stress can profoundly affect the productivity of a flock. At environmental

temperatures above 33°C, high mortality and large production losses are readily evident, but at less extreme temperatures, heat stress is often overlooked as a cause for poor growth or subtle losses in egg production and shell quality.

- Flocks raised in cold temperatures will struggle more as adult birds to adjust to hot weather.
- For information on management of layers in heat stress conditions, see **[Understanding Heat Stress in Layers](#)**.

Feather Pecking

Good feather cover is an important welfare trait in layer flocks. Feather cover protects the skin from injury and direct sunlight. Good feather cover provides insulation from the cold and improves feed efficiency. Older flocks with good feather cover are more marketable and have greater value.

Birds have a social hierarchy called the pecking order. Some pecking is normal behaviour to establish a stable social structure. In their natural environment birds spend a significant portion of the day foraging for food. Environments that limit foraging behaviour result in feather pecking. In extreme cases, cannibalism of other birds can occur. Currently, feather pecking is managed by reducing light intensity and beak trimming, which attenuate, but do not address the cause of the behaviour.



Bird with poor feather cover.

Factors Affecting the Incidence of Feather Pecking

Nutritional Deficiencies

- Low protein and amino acid imbalance, particularly methionine and arginine
- Low mineral levels, ie. calcium, sodium

Diet Characteristics

- Low fibre, fine textured or pelleted feed, and restricted feeding practices reduce the bird's feeding time
- Sudden changes in feed ingredients or feed particle size
- Pecking around the preen gland (near the tail) may indicate low salt in the diet or, in pullets 3–6 weeks of age, might be an indication of infectious bursal disease

Environmental Stressors

- Loud noises
- Heat stress
- Litter substrates, such as fine-particle wood shavings or sawdust
- Large flock sizes have a less stable social structure
- High stocking density, leading to overcrowding of the bird's floor, feeder, water, and nest space
- Mite infestation, even in moderate numbers

Flock Characteristics

- Poor beak trimming
- Poor uniformity

Tips for Preventing Excessive Feather Pecking Behaviour

- Prevention measures taken during the rearing and early production periods are more effective than in older flocks already exhibiting excessive feather pecking behaviour.
- Match rearing and production facility environments as closely as possible.
- Provide the recommended levels of light intensity in the facility. In flocks exhibiting excessive feather pecking behaviour, reduce light intensity to calm the flock.
- Ensure that nests are dark (< 0.5 lux).
- Minimise heat stress during the summer months. For more information, see **Understanding Heat Stress in Layers**.
- Quickly remove injured and dead birds from the flock.
- Remove any birds displaying aggressive pecking and cannibalistic behaviour.
- Keep facilities in good repair, eliminating loose wires, sharp edges and areas where birds can be caught.
- The use of nipple drinkers may reduce feather pecking.
- For more information, see Feather Scoring.

Good Lighting Practices

- Keep light bulbs and covers clean to prevent loss of light intensity.
- Prevent dark areas in the facility which can be created by too much distance between lights or burned-out light bulbs.
- Shiny or white surfaces reflect light, creating more uniform distribution.
- Take local conditions into account which may require adaptations to lighting programmes.
- Match light hours of rearing and production facilities at transfer.
- Light stimulation period should extend into the peaking period (achieve 16 hours of light by approximately 25 weeks).
- Light intensity (measured at the level of the feeders) should gradually increase for the 2 weeks before flock is transferred to the laying facility (but not prior to 15 weeks of age). Final rearing facility light intensity should match that of the production facility.

Light Programmes

- Use a slow step-down lighting programme for 0–8 weeks to increase the feed intake during the rearing period and to optimise pullet flock growth and uniformity. A slower step-down period can be used to achieve increased pullet weights and potentially increased egg weights.
- An intermittent lighting programme for chicks is preferred. If not using an intermittent lighting programme from 0–7 days, use 20 hours of light from 0–7 days.
- “Lights on” time can be varied between facilities in laying flocks to facilitate egg collection on multiple flock complexes.
- If the laying flock has a large spread in hatch ages and/or poor uniformity, light stimulate the flock based on the youngest hatch date or lightest birds.
- Use cool lights (3000–5000 K) in the rearing facility to ensure sufficient blue-green light spectrum. Use warm lights (2700–3500 K) in the production period to ensure sufficient red spectrum.
- For more information, see [Understanding Poultry Lighting](#).

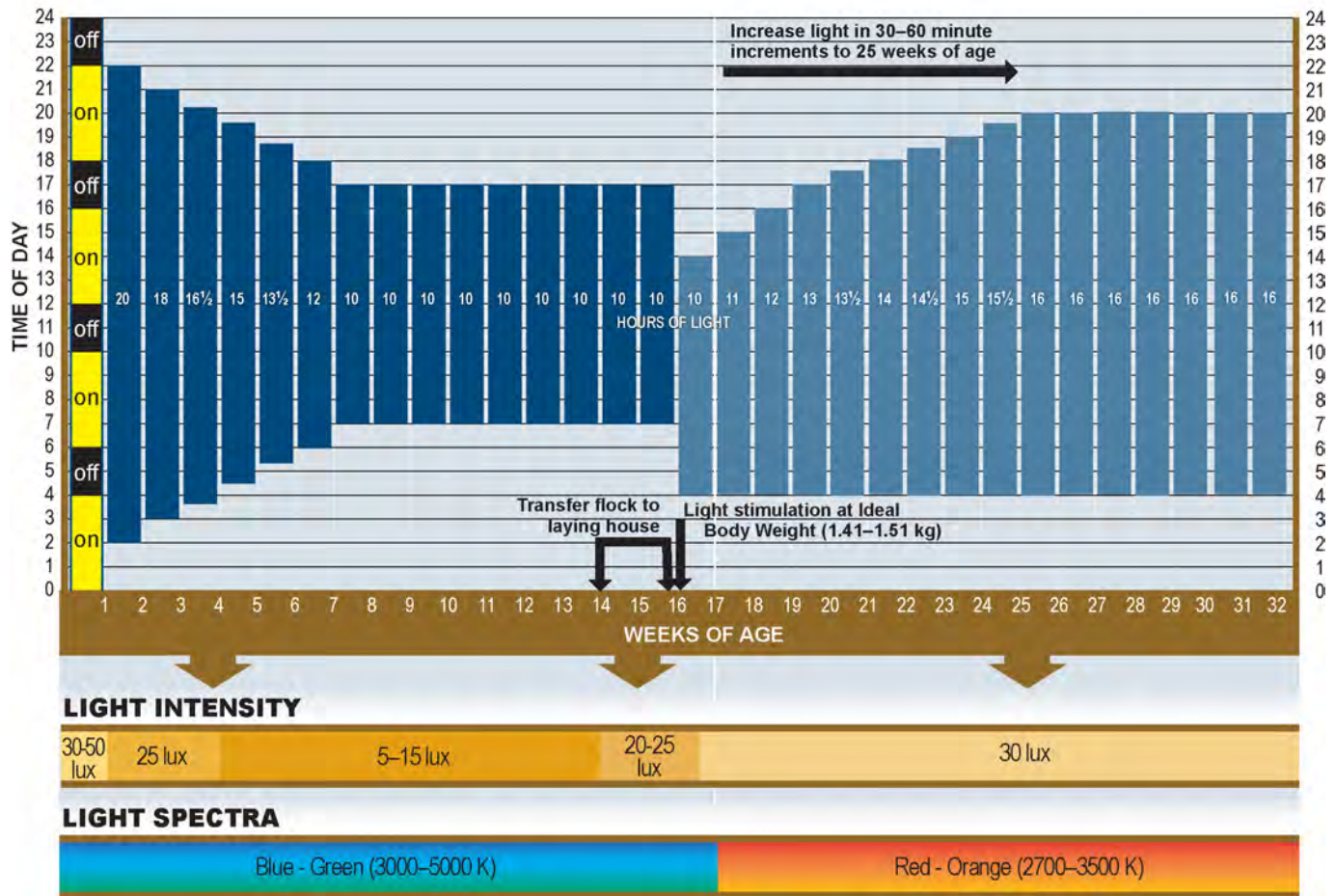

Customised Lighting Programmes for Open-Sided Housing

Houses with natural light influence can be difficult to manage depending on the season the chicks were hatched and the latitude of the farm. The **Hy-Line International Lighting Programme** can be used to help determine the sunrise and sunset of the flock and create a base programme. However, this programme may need to be customised to suite the exact location and management of the farm.

Midnight Feeding

- Optional lighting technique that promotes greater feed consumption.
- Used whenever more feed intake is desired in rearing or laying flocks.
- Increases calcium absorption during night when most eggshell is formed.
- Useful to increase feed intake during peak egg production.
- Helps maintain feed consumption in hot climates.
- Midnight feeding may increase feed intake 2–5 g/day per bird.
- Check local regulations on minimum periods of darkness

Good Practices:

- Initiate the program by turning lights on for 1–2 hours in the middle of the dark period.
- Fill feeders before lights are turned on.
- There must be at least 3 hours of dark before and after the midnight feeding.
- Light provided during the midnight feeding is in addition to regular day length (i.e. 16 hours + midnight feeding).
- If midnight feeding is removed, reduce light gradually at a rate of 15 minutes per week.

Use of Shades in Open-Sided Housing

- Shades are an effective way to decrease light intensity in an open-sided house.
- Shades must be porous to allow air flow through the curtain.
- Keep shades clean and free of dust to allow air flow.
- Use stir fans when using shades.
- Avoid direct sunlight on birds by using shades or roof overhangs.
- Black shades are preferred.



Rearing Period Nutritional Recommendations

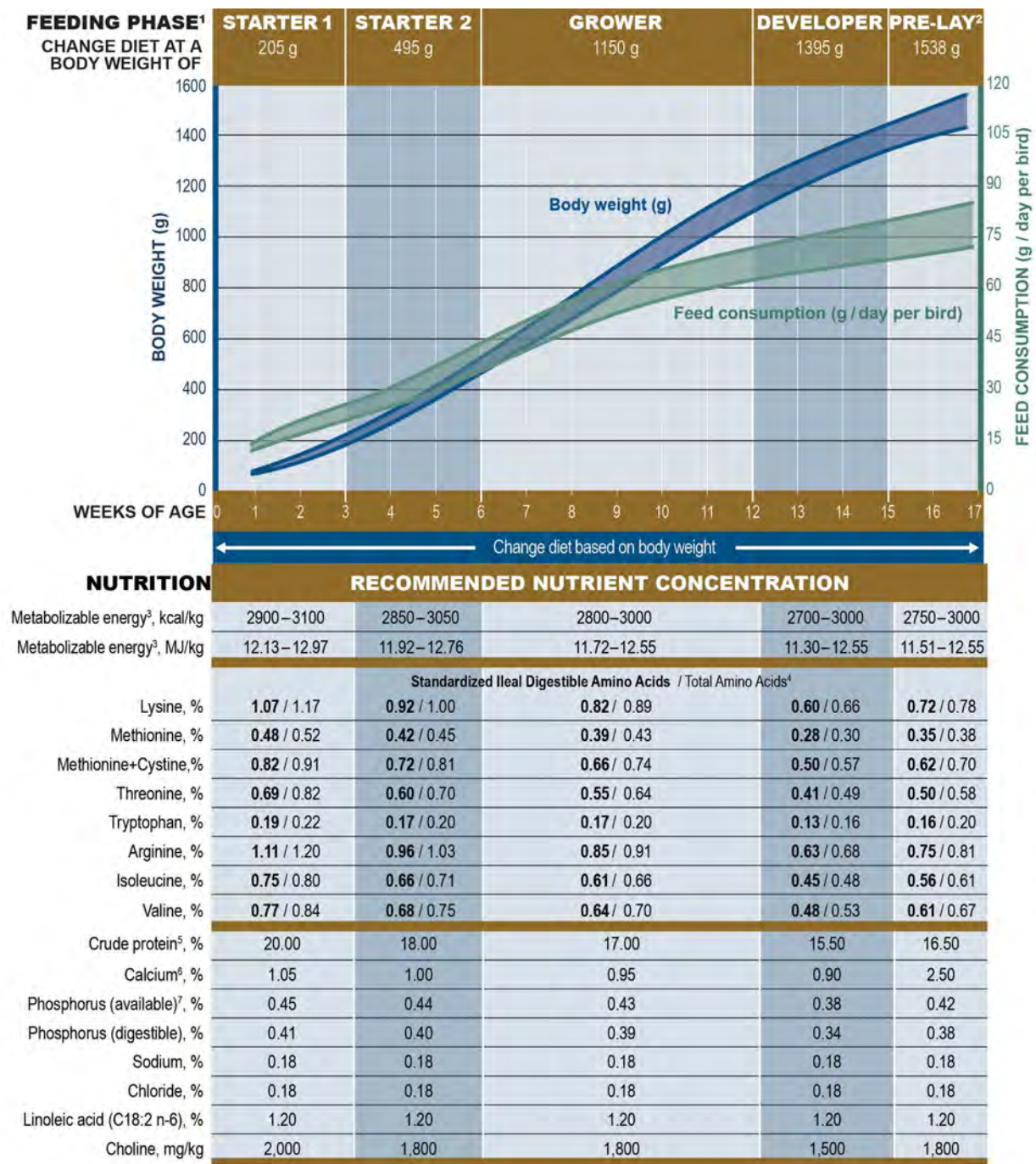

1. Body weights are approximate. Ages shown are a guide only. Please note that at time of transfer, there will be some loss in body weight (normally 10–12%) due to reduced water intake.
2. Do not feed Pre-Lay Diet earlier than 15 weeks of age. Do not feed Pre-Lay later than first egg as it contains insufficient calcium to support egg production. Implementing a pre-lay diet can be challenging in mixed-age flocks. If it's not possible to use the Pre-Lay diet, the calcium content of the last stage rearing diet (developer) must be increased to 1.4%.
3. Recommended energy range is based on raw material energy values shown in feed ingredient tables. It is important that target concentrations of dietary energy are adjusted according to energy system applied to raw material matrix.
4. Recommendation for Total Amino Acids is only appropriate to corn and soybean meal diet. Where diets utilise other ingredients, recommendations for Standardised Ileal Digestible Amino Acids must be followed.
5. Diets should always be formulated to provide required intake of amino acid. Concentration of crude protein in diet will vary with raw material used. Crude protein value provided is an estimated typical value only.
6. Calcium should be supplied as fine calcium carbonate (mean particle size less than 2 mm). Coarse limestone (2–4 mm) can be introduced in Pre-Lay Diet at up to 50% of total limestone.
7. Where other phosphorus systems are used, diets should contain recommended minimum level of available phosphorus.

Phase Feeding in Rear

Starter

- Starter feed is preferably in the form of a crumb with a particle size distribution between 1 to 3 mm and minimal levels of fine material (particles less than 1 mm) to support feed intake.
- Starters are formulated using ingredients which are both highly palatable and digestible for the chick with particular emphasis on protein contributors.
- If necessary, a second stage starter (Starter 2) diet can be used as an intermediate diet between the first stage starter (Starter 1) and Grower diet to further support development.
- Oil levels can be increased to 2.0% in starter diets when given as a mash to control dust and increase feed palatability.

Grower

- Typically given during the period of rapid growth in pullet body size between 6 and 12 weeks of age.
- Sufficient levels of protein, essential amino acids, and minerals are required for muscle growth and skeletal development during this period.
- Attention should be given to ensure that the nutrient density of the Grower diet is sufficient to compensate for any stress event which may compromise feed intake.

Developer

- Typically introduced at 12 weeks of age providing that body weight objectives have been achieved.
- The Developer diet should be fed up to the Pre-Lay period and be sufficiently low in density to encourage feed intake and increase enteric capacity.
- Fibre levels in the Developer diets are often higher than the Grower diet.
- The Developer diet can have a wide range of nutritional levels since it can be used either to increase or to control body weight gain.
- Avoid excessive levels of choline (> 150 ppm per bird per day) in the Developer phase to facilitate fat accumulation for the onset of lay.

Pre-Lay

- The Pre-Lay diet contains increased calcium and phosphorus levels relative to the Developer diet to increase medullary bone reserves in pullets preparing for egg production. Medullary bone contains minerals that are quickly mobilised for eggshell formation and vital for development of the first egg.
- Plan to feed for maximum of 10–14 days before point of lay.
- Pre-Lay diets can be started when most pullets show reddening of combs.
- Introduce large particle calcium sources, such as limestone, into the Pre-Lay diet in order to familiarise birds to large particles. Ideally, at least 50% of the limestone in the Pre-Lay diet should be coarse.
- When feeding, the Pre-Lay diet can be synchronised with light stimulation.
- Discontinue feeding the Pre-Lay diet with the commencement of egg production.

Nutritional Recommendations for Economical Performance

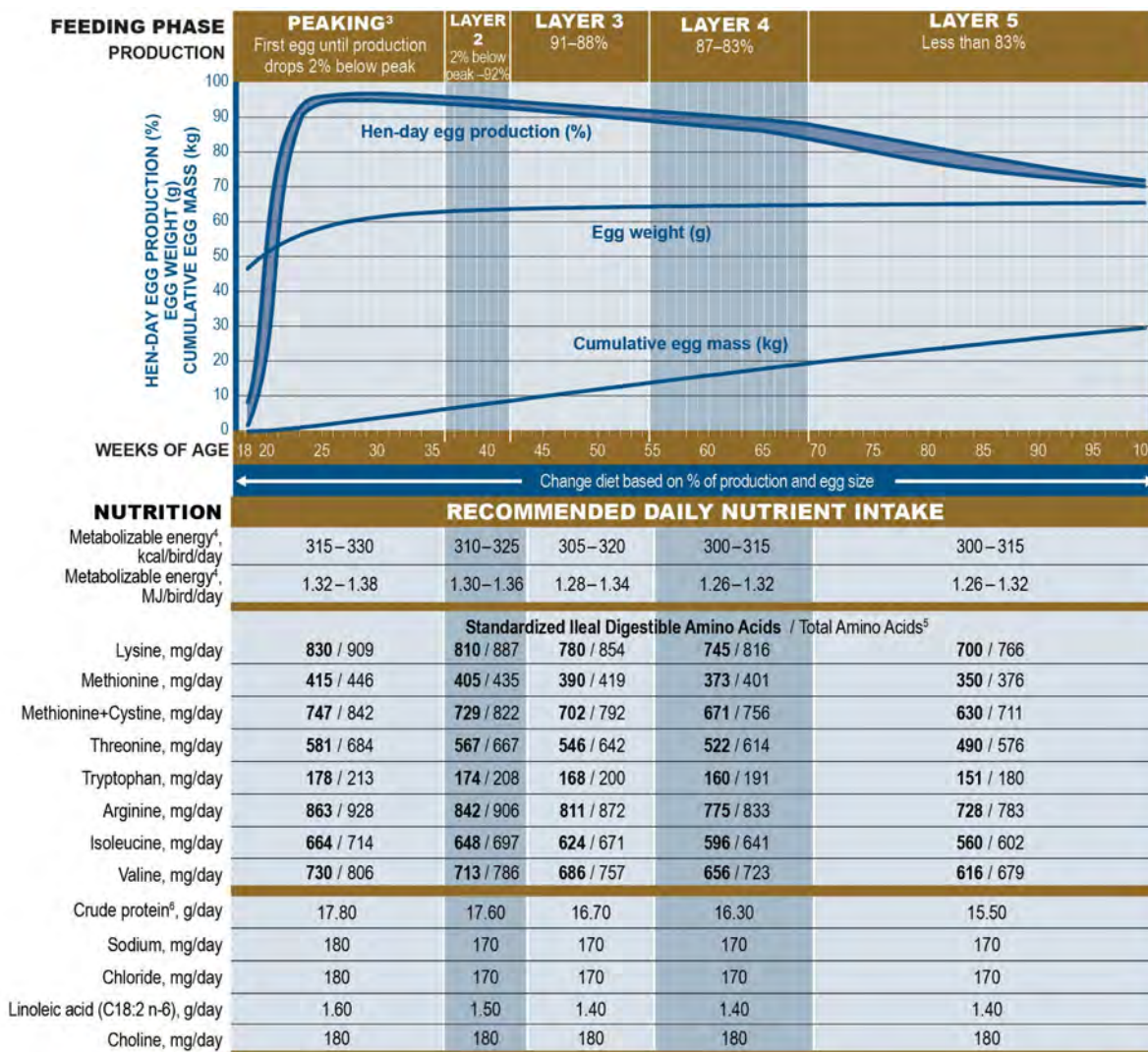

	CALCIUM AND PHOSPHORUS			
	Calcium ^{7,8} g/day	Phosphorus (available) ^{7,9} mg/day	Phosphorus (digestible) mg/day	Calcium Particle Size (fine : coarse)
Weeks 18-33	4.00	432	389	40% : 60%
Weeks 34-48	4.20	405	366	35% : 65%
Weeks 49-62	4.40	373	337	30% : 70%
Weeks 63-76	4.60	347	314	25% : 75%
Weeks 77+	4.70	324	291	25% : 75%

	IDEAL PROTEIN REFERENCE				
	PEAKING	LAYER 2	LAYER 3	LAYER 4	LAYER 5
Lysine	100%	100%	100%	100%	100%
Methionine	50%	50%	50%	50%	50%
M+C	90%	90%	90%	90%	89%
Threonine	70%	70%	70%	70%	70%
Tryptophan	22%	22%	22%	22%	22%
Arginine	104%	104%	104%	104%	104%
Isoleucine	80%	80%	80%	80%	80%
Valine	88%	88%	88%	88%	88%

Dietary Nutrient Concentrations for Economical Performance

FEEDING PHASE PRODUCTION NUTRITION ^{1,2}	PEAKING ³ First egg until production drops 2% below peak					LAYER 2 2% below peak to 92%					LAYER 3 91-88%					LAYER 4 87-83%					LAYER 5 Less than 83%									
	RECOMMENDED CONCENTRATION																													
Metabolisable energy ⁴ , kcal/bird/day	315-330					310-325					305-320					300-315					300-315									
Metabolisable energy ⁴ , MJ/bird/day	1.32-1.38					1.30-1.36					1.28-1.34					1.26-1.32					1.26-1.32									
FEED CONSUMPTION (*Typical Feed Consumption)																														
g/day per bird	90	95	100*	105	110	105	110	115*	120	125	105	111	117*	123	129	105	111	117*	123	129	105	111	117*	123	129	105	111	117*	123	129
Standardised Ileal Digestible Amino Acids																														
Lysine, %	0.92	0.87	0.83	0.79	0.75	0.77	0.74	0.70	0.68	0.65	0.74	0.70	0.67	0.63	0.60	0.71	0.67	0.64	0.61	0.58	0.67	0.63	0.60	0.57	0.54	0.67	0.63	0.60	0.57	0.54
Methionine, %	0.46	0.44	0.42	0.40	0.38	0.39	0.37	0.35	0.34	0.32	0.37	0.35	0.33	0.32	0.30	0.36	0.34	0.32	0.30	0.29	0.33	0.32	0.30	0.28	0.27	0.33	0.32	0.30	0.28	0.27
Methionine+Cystine, %	0.83	0.79	0.75	0.71	0.68	0.69	0.66	0.63	0.61	0.58	0.67	0.63	0.60	0.57	0.54	0.64	0.60	0.57	0.55	0.52	0.60	0.57	0.54	0.51	0.49	0.60	0.57	0.54	0.51	0.49
Threonine, %	0.65	0.61	0.58	0.55	0.53	0.54	0.52	0.49	0.47	0.45	0.52	0.49	0.47	0.44	0.42	0.50	0.47	0.45	0.42	0.40	0.47	0.44	0.42	0.40	0.38	0.47	0.44	0.42	0.40	0.38
Tryptophan, %	0.20	0.19	0.18	0.17	0.16	0.17	0.16	0.15	0.15	0.14	0.16	0.15	0.14	0.14	0.13	0.15	0.14	0.14	0.13	0.12	0.14	0.14	0.13	0.12	0.12	0.14	0.14	0.13	0.12	0.12
Arginine, %	0.96	0.91	0.86	0.82	0.78	0.80	0.77	0.73	0.70	0.67	0.77	0.73	0.69	0.66	0.63	0.74	0.70	0.66	0.63	0.60	0.69	0.66	0.62	0.59	0.56	0.69	0.66	0.62	0.59	0.56
Isoleucine, %	0.74	0.70	0.66	0.63	0.60	0.62	0.59	0.56	0.54	0.52	0.59	0.56	0.53	0.51	0.48	0.57	0.54	0.51	0.48	0.46	0.53	0.50	0.48	0.46	0.43	0.53	0.50	0.48	0.46	0.43
Valine, %	0.81	0.77	0.73	0.70	0.66	0.68	0.65	0.62	0.59	0.57	0.65	0.62	0.59	0.56	0.53	0.62	0.59	0.56	0.53	0.51	0.59	0.55	0.53	0.50	0.48	0.59	0.55	0.53	0.50	0.48
Total Amino Acids ⁵																														
Lysine, %	1.01	0.96	0.91	0.87	0.83	0.84	0.81	0.77	0.74	0.71	0.81	0.77	0.73	0.69	0.66	0.78	0.74	0.70	0.66	0.63	0.73	0.69	0.65	0.62	0.59	0.73	0.69	0.65	0.62	0.59
Methionine, %	0.50	0.47	0.45	0.42	0.41	0.41	0.40	0.38	0.36	0.35	0.40	0.38	0.36	0.34	0.32	0.38	0.36	0.34	0.33	0.31	0.36	0.34	0.32	0.31	0.29	0.36	0.34	0.32	0.31	0.29
Methionine+Cystine, %	0.94	0.89	0.84	0.80	0.77	0.78	0.75	0.71	0.69	0.66	0.75	0.71	0.68	0.64	0.61	0.72	0.68	0.65	0.61	0.59	0.68	0.64	0.61	0.58	0.55	0.68	0.64	0.61	0.58	0.55
Threonine, %	0.76	0.72	0.68	0.65	0.62	0.64	0.61	0.58	0.56	0.53	0.61	0.58	0.55	0.52	0.50	0.58	0.55	0.52	0.50	0.48	0.55	0.52	0.49	0.47	0.45	0.55	0.52	0.49	0.47	0.45
Tryptophan, %	0.24	0.22	0.21	0.20	0.19	0.20	0.19	0.18	0.17	0.17	0.19	0.18	0.17	0.16	0.16	0.18	0.17	0.16	0.15	0.15	0.17	0.16	0.15	0.15	0.14	0.17	0.16	0.15	0.15	0.14
Arginine, %	1.03	0.98	0.93	0.88	0.84	0.86	0.82	0.79	0.76	0.72	0.83	0.79	0.75	0.71	0.68	0.79	0.75	0.71	0.68	0.65	0.75	0.71	0.67	0.64	0.61	0.75	0.71	0.67	0.64	0.61
Isoleucine, %	0.79	0.75	0.71	0.68	0.65	0.66	0.63	0.61	0.58	0.56	0.64	0.60	0.57	0.55	0.52	0.61	0.58	0.55	0.52	0.50	0.57	0.54	0.51	0.49	0.47	0.57	0.54	0.51	0.49	0.47
Valine, %	0.90	0.85	0.81	0.77	0.73	0.75	0.71	0.68	0.66	0.63	0.72	0.68	0.65	0.62	0.59	0.69	0.65	0.62	0.59	0.56	0.65	0.61	0.58	0.55	0.53	0.65	0.61	0.58	0.55	0.53
Crude protein ⁶ , %	19.78	18.74	17.80	16.95	16.18	16.76	16.00	15.30	14.67	14.08	15.90	15.05	14.27	13.58	12.95	15.52	14.68	13.93	13.25	12.64	14.76	13.96	13.25	12.60	12.02	14.76	13.96	13.25	12.60	12.02
Sodium, %	0.20	0.19	0.18	0.17	0.16	0.16	0.15	0.15	0.14	0.14	0.16	0.15	0.15	0.14	0.13	0.16	0.15	0.15	0.14	0.13	0.16	0.15	0.15	0.14	0.13	0.16	0.15	0.15	0.14	0.13
Chloride, %	0.20	0.19	0.18	0.17	0.16	0.16	0.15	0.15	0.14	0.14	0.16	0.15	0.15	0.14	0.13	0.16	0.15	0.15	0.14	0.13	0.16	0.15	0.15	0.14	0.13	0.16	0.15	0.15	0.14	0.13
Linoleic acid (C18:2 n-6), %	1.78	1.68	1.60	1.52	1.45	1.43	1.36	1.30	1.25	1.20	1.33	1.26	1.20	1.14	1.09	1.33	1.26	1.20	1.14	1.09	1.33	1.26	1.20	1.14	1.09	1.33	1.26	1.20	1.14	1.09
Choline, mg/kg	2000	1895	1800	1714	1636	1714	1636	1565	1500	1440	1714	1622	1538	1463	1395	1714	1622	1538	1463	1395	1714	1622	1538	1463	1395	1714	1622	1538	1463	1395
CALCIUM AND PHOSPHORUS CHANGES BASED ON FEED INTAKE																														
Feed Consumption, g/day per bird	Weeks 18-33					Weeks 34-48					Weeks 49-62					Weeks 63-76					Weeks 77+									
	90	95	100	106	112	118	124	100	106	112	118	124	100	106	112	118	124	100	106	112	118	124	100	106	112	118	124			
Calcium ^{7,8} , %	4.44	4.21	4.00	3.81	3.64	3.48	3.33	4.20	4.00	3.82	3.65	3.50	4.40	4.19	4.00	3.83	3.67	4.60	4.38	4.18	4.00	3.83	4.70	4.48	4.27	4.09	3.92			
Phosphorus (available) ^{7,9} , %	0.48	0.46	0.43	0.41	0.39	0.38	0.36	0.41	0.39	0.37	0.35	0.34	0.37	0.36	0.34	0.32	0.31	0.35	0.33	0.32	0.30	0.29	0.32	0.31	0.29	0.28	0.27			
Phosphorus (digestible), %	0.43	0.41	0.39	0.37	0.35	0.34	0.32	0.37	0.35	0.33	0.32	0.31	0.34	0.32	0.31	0.29	0.28	0.31	0.30	0.29	0.27	0.26	0.29	0.28	0.26	0.25	0.24			

Nutritional Recommendations for Optimal Performance

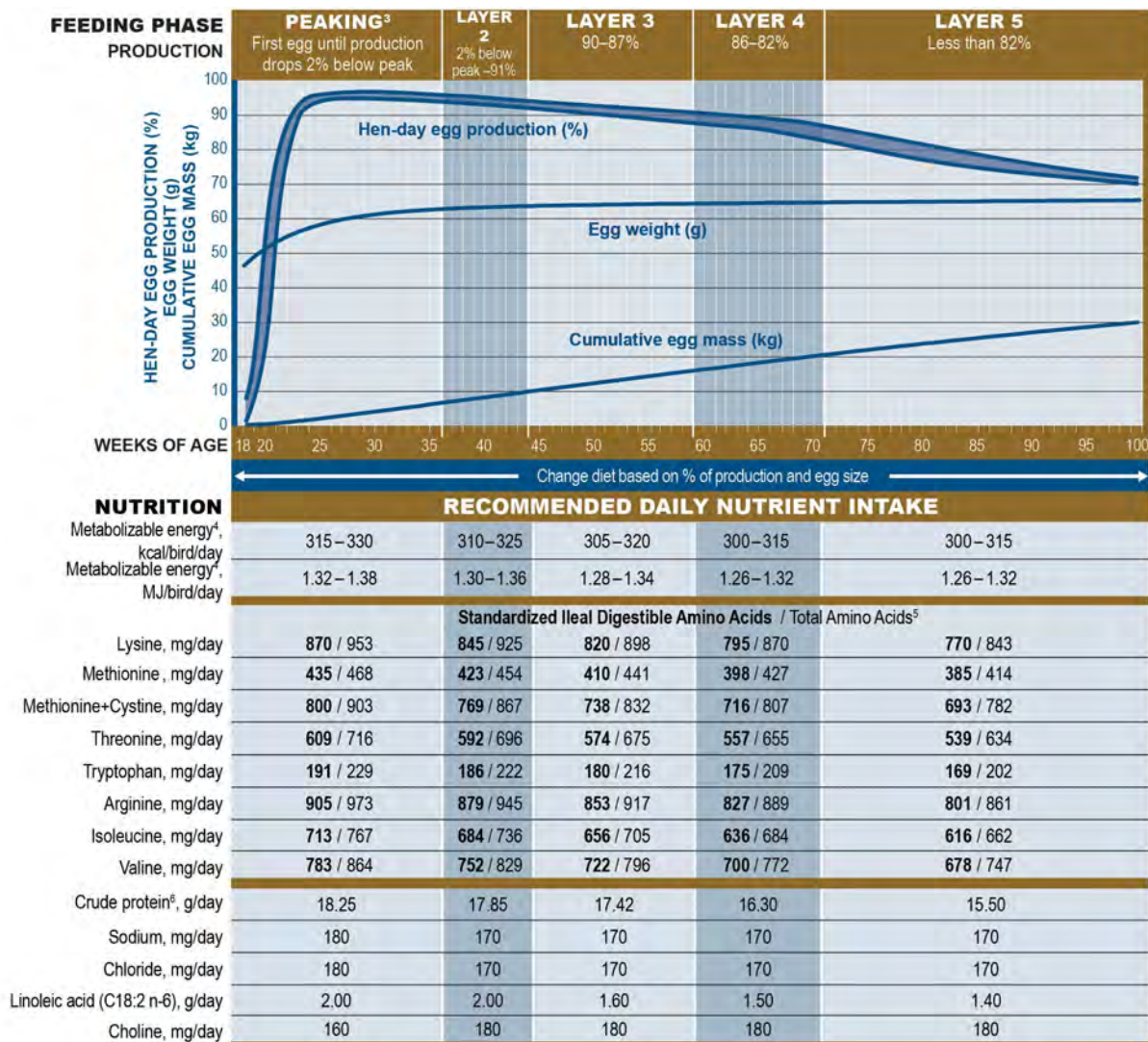

	CALCIUM AND PHOSPHORUS			
	Calcium ^{7,8} g/day	Phosphorus (available) ⁹ mg/day	Phosphorus (digestible) mg/day	Calcium Particle Size (fine : coarse)
Weeks 18-33	4.00	432	389	40% : 60%
Weeks 34-48	4.20	405	366	35% : 65%
Weeks 49-62	4.40	373	337	30% : 70%
Weeks 63-76	4.60	347	314	25% : 75%
Weeks 77+	4.70	324	291	25% : 75%

	IDEAL PROTEIN REFERENCE				
	PEAKING	LAYER 2	LAYER 3	LAYER 4	LAYER 5
Lysine	100%	100%	100%	100%	100%
Methionine	50%	50%	50%	50%	50%
M+C	92%	91%	90%	90%	90%
Threonine	70%	70%	70%	70%	70%
Tryptophan	22%	22%	22%	22%	22%
Arginine	104%	104%	104%	104%	104%
Isoleucine	82%	81%	80%	80%	80%
Valine	90%	89%	88%	88%	88%

Dietary Nutrient Concentrations for Optimal Performance

FEEDING PHASE PRODUCTION NUTRITION ^{1,2}	PEAKING ³ First egg until production drops 2% below peak					LAYER 2 2% below peak to 91%					LAYER 3 90-87%					LAYER 4 86-82%					LAYER 5 Less than 82%						
	RECOMMENDED CONCENTRATION																										
Metabolisable energy ⁴ , kcal/bird/day	315-330					310-325					305-320					300-315					300-315						
Metabolisable energy ⁴ , MJ/bird/day	1.32-1.38					1.30-1.36					1.28-1.34					1.26-1.32					1.26-1.32						
FEED CONSUMPTION (*Typical Feed Consumption)																											
g/day per bird	90	95	100*	105	110	105	110	115*	120	125	105	111	117*	123	129	105	111	117*	123	129	105	111	117*	123	129		
Standardised Ileal Digestible Amino Acids																											
Lysine, %	0.97	0.92	0.87	0.83	0.79	0.80	0.77	0.73	0.70	0.68	0.78	0.74	0.70	0.67	0.64	0.76	0.72	0.68	0.65	0.62	0.73	0.69	0.66	0.63	0.60		
Methionine, %	0.48	0.46	0.44	0.41	0.40	0.40	0.38	0.37	0.35	0.34	0.39	0.37	0.35	0.33	0.32	0.38	0.36	0.34	0.32	0.31	0.37	0.35	0.33	0.31	0.30		
Methionine+Cystine, %	0.89	0.84	0.80	0.76	0.73	0.73	0.70	0.67	0.64	0.62	0.70	0.66	0.63	0.60	0.57	0.68	0.65	0.61	0.58	0.56	0.66	0.62	0.59	0.56	0.54		
Threonine, %	0.68	0.64	0.61	0.58	0.55	0.56	0.54	0.51	0.49	0.47	0.55	0.52	0.49	0.47	0.44	0.53	0.50	0.48	0.45	0.43	0.51	0.49	0.46	0.44	0.42		
Tryptophan, %	0.21	0.20	0.19	0.18	0.17	0.18	0.17	0.16	0.16	0.15	0.17	0.16	0.15	0.15	0.14	0.17	0.16	0.15	0.14	0.14	0.16	0.15	0.14	0.14	0.13		
Arginine, %	1.01	0.95	0.91	0.86	0.82	0.84	0.80	0.76	0.73	0.70	0.81	0.77	0.73	0.69	0.66	0.79	0.75	0.71	0.67	0.64	0.76	0.72	0.68	0.65	0.62		
Isoleucine, %	0.79	0.75	0.71	0.68	0.65	0.65	0.62	0.59	0.57	0.55	0.62	0.59	0.56	0.53	0.51	0.61	0.57	0.54	0.52	0.49	0.59	0.55	0.53	0.50	0.48		
Valine, %	0.87	0.82	0.78	0.75	0.71	0.72	0.68	0.65	0.63	0.60	0.69	0.65	0.62	0.59	0.56	0.67	0.63	0.60	0.57	0.54	0.65	0.61	0.58	0.55	0.53		
Total Amino Acids ⁵																											
Lysine, %	1.06	1.00	0.95	0.91	0.87	0.88	0.84	0.80	0.77	0.74	0.86	0.81	0.77	0.73	0.70	0.83	0.78	0.74	0.71	0.67	0.80	0.76	0.72	0.69	0.65		
Methionine, %	0.52	0.49	0.47	0.45	0.43	0.43	0.41	0.39	0.38	0.36	0.42	0.40	0.38	0.36	0.34	0.41	0.38	0.36	0.35	0.33	0.39	0.37	0.35	0.34	0.32		
Methionine+Cystine, %	1.00	0.95	0.90	0.86	0.82	0.83	0.79	0.75	0.72	0.69	0.79	0.75	0.71	0.68	0.64	0.77	0.73	0.69	0.66	0.63	0.74	0.70	0.67	0.64	0.61		
Threonine, %	0.80	0.75	0.72	0.68	0.65	0.66	0.63	0.61	0.58	0.56	0.64	0.61	0.58	0.55	0.52	0.62	0.59	0.56	0.53	0.51	0.60	0.57	0.54	0.52	0.49		
Tryptophan, %	0.25	0.24	0.23	0.22	0.21	0.21	0.20	0.19	0.19	0.18	0.21	0.19	0.18	0.18	0.17	0.20	0.19	0.18	0.17	0.16	0.19	0.18	0.17	0.16	0.16		
Arginine, %	1.08	1.02	0.97	0.93	0.88	0.90	0.86	0.82	0.79	0.76	0.87	0.83	0.78	0.75	0.71	0.85	0.80	0.76	0.72	0.69	0.82	0.78	0.74	0.70	0.67		
Isoleucine, %	0.85	0.81	0.77	0.73	0.70	0.70	0.67	0.64	0.61	0.59	0.67	0.64	0.60	0.57	0.55	0.65	0.62	0.58	0.56	0.53	0.63	0.60	0.57	0.54	0.51		
Valine, %	0.96	0.91	0.86	0.82	0.79	0.79	0.75	0.72	0.69	0.66	0.76	0.72	0.68	0.65	0.62	0.74	0.70	0.66	0.63	0.60	0.71	0.67	0.64	0.61	0.58		
Crude protein ⁶ , %	20.28	19.21	18.25	17.38	16.59	17.00	16.23	15.52	14.88	14.28	16.59	15.69	14.89	14.16	13.50	15.52	14.68	13.93	13.25	12.64	14.76	13.96	13.25	12.60	12.01		
Sodium, %	0.20	0.19	0.18	0.17	0.16	0.16	0.15	0.15	0.14	0.14	0.16	0.15	0.15	0.14	0.13	0.16	0.15	0.15	0.14	0.13	0.16	0.15	0.15	0.14	0.13		
Chloride, %	0.20	0.19	0.18	0.17	0.16	0.16	0.15	0.15	0.14	0.14	0.16	0.15	0.15	0.14	0.13	0.16	0.15	0.15	0.14	0.13	0.16	0.15	0.15	0.14	0.13		
Linoleic acid (C18:2 n-6), %	2.22	2.11	2.00	1.90	1.82	1.90	1.82	1.74	1.67	1.60	1.52	1.44	1.37	1.30	1.24	1.43	1.35	1.28	1.22	1.16	1.33	1.26	1.20	1.14	1.09		
Choline, mg/kg	1778	1684	1600	1524	1455	1714	1636	1565	1500	1440	1714	1622	1538	1463	1395	1714	1622	1538	1463	1395	1714	1622	1538	1463	1395		
CALCIUM AND PHOSPHORUS CHANGES BASED ON FEED INTAKE																											
	Weeks 18-33					Weeks 34-48					Weeks 49-62					Weeks 63-76					Weeks 77+						
Feed Consumption, g/day per bird	90	95	100	106	112	118	124	100	106	112	118	124	100	106	112	118	124	100	106	112	118	124	100	106	112	118	124
Calcium ^{7,8} , %	4.44	4.21	4.00	3.81	3.64	3.48	3.33	4.20	4.00	3.82	3.65	3.50	4.40	4.19	4.00	3.83	3.67	4.60	4.38	4.18	4.00	3.83	4.70	4.48	4.27	4.09	3.92
Phosphorus (available) ^{7,5} , %	0.48	0.46	0.43	0.41	0.39	0.38	0.36	0.41	0.39	0.37	0.35	0.34	0.37	0.36	0.34	0.32	0.31	0.35	0.33	0.32	0.30	0.29	0.32	0.31	0.29	0.28	0.27
Phosphorus (digestible), %	0.43	0.41	0.39	0.37	0.35	0.34	0.32	0.37	0.35	0.33	0.32	0.31	0.34	0.32	0.31	0.29	0.28	0.31	0.30	0.29	0.27	0.26	0.29	0.28	0.26	0.25	0.24

1. All nutrient requirements are based on the Feed Ingredient Tables.
2. Crude protein, methionine+cystine, fat, linoleic acid, and / or energy may be changed to optimise egg size.
3. Peaking nutrient levels are calculated for birds at peak egg production. Prior to achieving peak egg production, the nutrient requirements will be lower.
4. A good approximation of the influence of temperature on energy needs is that for each 0.5°C change higher or lower than 22°C, subtract or add about 2 kcal /bird /day, respectively.
5. Recommendation for Total Amino Acids is only appropriate to corn and soybean meal diet. Where diets utilise other ingredients, recommendations for Standardised Ileal Digestible Amino Acids must be followed.
6. Diets should always be formulated to provide required intake of amino acid. Concentration of crude protein in diet will vary with raw material used. Crude protein value provided is an estimated typical value only.
7. Calcium and available phosphorus requirements are determined by flock age. When production remains higher and diets are fed for longer than ages shown, it is recommended to increase to calcium and phosphorus concentrations of next feeding phase.
8. Calcium carbonate particle size recommendation varies throughout lay. Refer to Calcium Particle Size. Dietary calcium levels and fine to coarse ratio may need to be adjusted based on limestone solubility.
9. Where other phosphorus systems are used, diets should contain recommended minimum level of available phosphorus.

Phase Feeding in Production

Pre-Peak

- Pre-Peak diets are intended for flocks with low feed intake and are fed for a limited period from first egg to the beginning of peak production. The nutrient specification of the Pre-Peak diet should be dense enough to allow for lower feed intake and also cater to the increased nutritional needs of the bird entering egg production. Continue to feed the Pre-Peak until feed intake has developed sufficiently to allow transition to the Peak diet.
- If utilised until no more than 50–70% HD, a Pre-Peak diet with reduced energy concentration can be beneficial to stimulate feed intake. Pre-Peaking diets are useful in situations where local conditions may result in reduced feed intake, such as hot climates where feed intake may be depressed.
- Increasing the vitamins and trace mineral inclusion to 30% can be useful to cope with the lower feed intake during the Pre-Peak phase.

Peaking Ration

- Peaking rations need to be formulated according to actual flock feed consumption and egg mass output. Increase vitamin and trace mineral levels in these low intake diets if not already increased during the Pre-Peak phase.
- Begin feeding the Peaking diet at the onset of lay (1% egg production), if a Pre-Peak diet is not given.
- Birds should continue to grow during the Peak production period. Inadequate nutrient intake in this period can lead to loss of body weight (or insufficient body weight gain), soft bones, and loss of performance after Peak.
- Monitor keel bone development during the peaking period. See **Understanding the Role of the Skeleton in Egg Production**.

Phase Feeding during the Egg Production Period

- As the flock progresses through lay, the diet specification should be based on the bird's feed intake and egg mass output. In laying hens, the calcium requirement increases while the phosphorus requirement

decreases with age. Maintaining good eggshell quality through adequate provision of minerals is key to successful extended cycle egg production.

- Around 32 weeks of age, the medullary bone is completely formed and filled, and the phosphorus levels can be decreased.
- Control of egg size is critical in maintaining eggshell quality in older laying flocks. See **Optimising Egg Size in Commercial Layers**.

Calcium Particle Size

- The introduction of large particle calcium should begin with the Pre-Lay diet. The digestion of large particle calcium provides the laying hen with a slow, sustained availability of calcium for eggshell formation.
- The percentage of large particle calcium is gradually increased during the production period. Toward the end of lay, the proportion of large particle limestone should be 75% of the total calcium (depending on the limestone solubility).
- The appropriate particle size depends on the solubility of limestone. Large particle size calcium sources are generally between 2–4 mm in diameter.
- Dietary calcium levels may need to be adjusted based on limestone solubility.
- Coarse limestone with higher solubility will be retained for a shorter period, so it needs to be included at a higher proportion or larger particle size.
- Limestone which is dark in colour is geologically older. Typically, these contain more impurities (usually magnesium) and are generally lower in both solubility and calcium availability.
- Oyster shell and other marine shells (with low microbiological contamination) are good sources of soluble calcium.

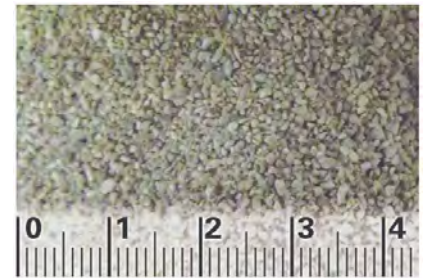

Fine calcium (0–2 mm).

Photo: Longcliff Quarries Ltd.



Coarse calcium (2–4 mm).

Photo: Longcliff Quarries Ltd.

PARTICLE SIZE	STARTER, GROWER, DEVELOPER	WEEKS 18-33	WEEKS 34-48	WEEKS 49-62	WEEKS 63-76	WEEKS 77+
Fine (0-2 mm)	100%	40%	35%	30%	25%	25%
Coarse (2-4 mm)	-	60%	65%	70%	75%	75%

Egg Size Management

- Closely monitor egg weight of each flock and make nutritional changes as needed to ensure the target egg weight profile is achieved. If smaller eggs are desired, egg weight should be controlled at an early age.
- Along with management practices, egg weight control is achieved by controlling amino acid and energy intake and ensuring that feed intake is not too high.
- Reducing only the methionine or sulphur-containing amino acids is not the best way to control egg weight since it can lead to poor performance and reduced feather coverage.
- Monitor egg weight as frequently as possible. Start plans for controlling egg weight when average egg weight is within 2 g of target egg weight.
- For more information, see [Optimising Egg Size in Commercial Layers](#).

Vitamins and Trace Minerals

As the vitamin/trace mineral premix is often found in fine feed particles, a minimum level of 1% added liquid oil/fat in diets binds small particles in feed.

ITEM ^{1,2,3,4}	IN 1000 KG COMPLETE DIET	
	Rearing Period	Production Period
Vitamin A, IU	10,000,000	8,000,000
Vitamin D ₃ ⁵ , IU	3,300,000	3,300,000
Vitamin E, g	25	20
Vitamin K (menadione), g	3.5	2.5
Thiamin (B ₁), g	2.2	2.5
Riboflavin (B ₂), g	6.6	5.5
Niacin (B ₃) ⁶ , g	40	30
Pantothenic acid (B ₅), g	10	8
Pyridoxine (B ₆), g	4.5	4
Biotin (B ₇), mg	100	75
Folic acid (B ₉), g	1	0.9
Cobalamine (B ₁₂), mg	23	23
Manganese ⁷ , g	90	90
Zinc ⁷ , g	85	80
Iron ⁷ , g	30	40
Copper ⁷ , g	15	8
Iodine, g	1.5	1.2
Selenium ⁷ , g	0.25	0.22

1. Minimum recommendations for rearing and laying periods. Local regulations may limit dietary content of individual vitamins or minerals.
2. Store premixes according to supplier's recommendations and observe 'use by' dates to ensure vitamin activity is maintained. Inclusion of antioxidant may improve premix stability.
3. Vitamin and mineral recommendations vary according to activity.
4. Where heat treatment is applied to diet, higher levels of vitamins may be required. Consult with vitamin supplier regarding stability through individual production processes.
5. A proportion of Vitamin D₃ can be supplemented as 25-hydroxy D₃ according to supplier's recommendations and applicable limits.
6. Higher levels of Niacin are recommended in non-cage systems.
7. Greater bioavailability and productivity may be possible with use of chelated mineral sources.

Feeding Programmes

Basic Feeding Programme for Layers

Morning Feeding (First Feeding)

- First feeder run is usually scheduled with lights-on or just after.
- Fresh feed should be available as birds become active and are coming down from resting sites.
- **Stacked morning feeding programme** is an optional feeding programme that provides two morning feedings one hour apart. Stacked morning feeding provides more feeding opportunities to ensure good nutrient intake in all birds. Stacked morning feeding may reduce floor eggs by reducing crowding in the nest area. The second feed in a stacked feeding schedule attracts early laying dominant hens off the nests to the feeders. This may create more nesting opportunities for other less dominant hens.

Second Feeding

- The second feeder run should occur at the end of the peak egg laying period, usually 4–5 hours after lights on. This time can vary between flocks.
- This feeding is important after the 4–5 hour gap following the morning feeding, as feed levels tend to be low at this time.
- This feeding also attracts hens out of the nests that may be sitting on eggs, providing nesting opportunities for late laying hens.

Afternoon Feedings

- One to three afternoon feedings can be scheduled depending on the type of feeding system, climate, flock performance, body weight, and feed accumulation in feeders.
- During periods of heat stress, afternoon feedings can be adjusted or removed to avoid birds eating during the hottest time of the day.
- One longer time gap between two afternoon feedings can be provided to encourage birds to consume fine feed particles and clean up feeders.
- Typically, the flock will consume 60% of the daily total feed in the afternoon.

Feed Consumption

- Hens should always have access to feed.
- A phase-feeding programme should be practiced to ensure correct nutrient consumption throughout lay. The purpose of phase feeding is to match nutrient intake with requirements by the bird.
- Layer diets should be formulated according to the actual feed consumption and level of desired production (egg mass output).
- Stimulate feed consumption by running feeders without adding additional feed.

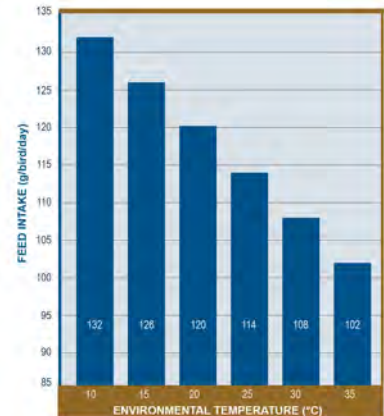

Approximate relationship between feed intake and environmental temperature.

- Manage feeders so that additional feedings do not create excessive fine feed particles.
- The hens' feed consumption rate is governed by several factors, including body weight (or age), egg mass output, ambient temperature, feed texture, health status, and the energy density of the diet.
- Laying hens have limited capacity to adjust their feed consumption to meet their needs for specific nutrients. It is important that performance and feed intake is monitored so that necessary adjustments to diet density can be made.
- After 10 weeks of age, brown pullets tend to be more responsive to the nutrient density of the diet from the point of feed intake—in other words, hens will consume more of a low-energy diet than a high-energy diet.
- Heat stress results in lower feed and therefore lower nutrient intake. Increasing the digestibility of the feed, in particular amino acids, and providing adequate energy in the form of lipids can result in better body weight gain, egg production, and egg weight when the effective ambient temperature is high. For more information, see **Understanding Heat Stress in Layers**.
- Fats or oils are concentrated sources of energy and can be useful in increasing the energy content and palatability of feed.
- During heat stress, do not increase the energy at the same proportion of the percentage of the feed intake drop, as this will further limit feed

intake.

- Vitamins, minerals, and amino acids should be adjusted according to feed intake.
- Vegetable oils are typically high in linoleic acid, which is useful for increasing egg size up to certain limits. A blend of unsaturated vegetable oils will have the same effect.

Feed Particle Size

- A sieve shaker (see below) separates a feed sample into categories based on particle size.
- Use on the farm to check the feed particle size from the feed mill by testing delivery samples. Testing feed in the farm system can be done; however, bird manipulation of the feed in troughs can have misleading effects. Assess samples from the feeding system by taking samples from various points along the entire track.
- Too many fine feed particles (<1 mm) results in:
 - Decreased feed intake
 - Increased dust levels in the facility
- Too many coarse feed particles results in:
 - Birds selectively eating large particles, creating uneven nutrient intake
 - Increased risk of feed separation
- Separation of large particles is a particular problem with flat chain feeders.
- Feed segregation with coarser presentations is also a problem in large feed bins, where free falls are higher than 4 m (from the tip of the truck auger to the bottom of the bin).



Hy-Line sieve shaker

Best Practices

- A 3–4 hour gap in feedings at mid-day allows birds to consume fine particles.
- Add a minimum of 1% liquid oil/fat in meal diets to create a more homogenous meal.
- Use larger particle size meal or crumb to increase feed intake in hot climates.
- Use crumb starter feeds to promote feed intake and even nutrient uptake in chicks.
- Use a coarse mash feed for Grower, Developer, Pre-Lay, and Layer.
- For more information, see **Feed Granulometry and the Importance of Feed Particle Size in Layers.**

PARTICLE SIZE	STARTER	GROWER	DEVELOPER	PRODUCTION
< 1 mm	1–3 mm diameter, crumb feed should contain < 10% fine feed particles	< 15%	< 15%	< 15%
1–2 mm		45–60%	25–35%	20–30%
2–3 mm		10–25%	25–40%	30–40%
> 3 mm		–	5–10%	10–15%

Optimal feed particle profile

Feed Ingredient Tables

INGREDIENT (as-fed basis)	DRY MATTER (%)	CRUDE PROTEIN (%)	FAT-ether extract (%)	CRUDE FIBRE	CALCIUM (%)	PHOSPHORUS total (%)	PHOSPHORUS available (%)	SODIUM (%)	CHLORIDE (%)	POTASSIUM (%)	SULPHUR (%)	ME (kcal/lb)	ME (kcal/kg)	ME (MJ/kg)	LINOLEIC ACID (%)	CHOLINE (mg/kg)
Barley, grain	89.0	11.5	1.9	5.0	0.08	0.42	0.15	0.03	0.14	0.56	0.15	1250	2750	11.51	1.1	1027
Beans, broad (vicia faba)	89.0	25.7	1.4	8.2	0.14	0.54	0.20	0.08	0.04	1.20	-	1100	2420	10.13	0.9	1670
Calcium carbonate (38% Ca)	99.0	-	-	-	38.00	-	-	0.06	-	0.06	-	-	-	-	-	-
Canola meal (38%) ¹	91.0	38.0	3.8	11.1	0.68	1.20	0.40	-	-	1.29	1.00	960	2110	8.83	-	6700
Corn, yellow, grain	86.0	7.5	3.5	1.9	0.01	0.28	0.12	0.02	0.04	0.33	0.08	1530	3373	14.11	1.9	1100
Corn gluten meal (60%)	90.0	60.0	2.0	2.5	0.02	0.50	0.18	0.03	0.05	0.45	0.50	1700	3740	15.65	1.8	2200
Cottonseed meal (41%), mech. extd	91.0	41.0	3.9	12.6	0.17	0.97	0.32	0.04	0.04	1.20	0.40	955	2100	8.79	0.8	2807
Cottonseed meal (41%), direct solv.	90.0	41.0	2.1	11.3	0.16	1.00	0.32	0.04	0.04	1.16	0.30	915	2010	8.41	0.4	2706
Dicalcium phosphate (18.5% P)	99.0	-	-	-	22.00	18.50	18.50	0.08	-	0.07	-	-	-	-	-	-
DL-Methionine	99.0	58.1	-	-	-	-	-	-	-	-	-	2277	5020	21.00	-	-
Fat, animal	99.0	-	98.0	-	-	-	-	-	-	-	-	3600	7920	33.14	-	-
Fat, vegetable	99.0	-	99.0	-	-	-	-	-	-	-	-	4000	8800	36.82	40.0	-
Fish meal, anchovy, Peruvian	91.0	65.0	10.0	1.0	-	-	-	0.88	0.60	0.90	0.54	1280	2820	11.80	0.1	5100
Fish meal, white	91.0	61.0	4.0	1.0	-	-	-	0.97	0.50	1.10	0.22	1180	2600	10.88	0.1	4050
Flaxseed	92.0	22.0	34.0	6.5	-	-	-	0.08	-	1.50	-	1795	3957	16.56	54.0	3150
L-Lysine	99.0	93.4	-	-	-	-	-	-	-	-	-	1868	4120	17.24	-	-
L-Threonine	99.0	72.4	-	-	-	-	-	-	-	-	-	1619	3570	14.94	-	-
L-Tryptophan	99.0	84.0	-	-	-	-	-	-	-	-	-	2653	5850	24.48	-	-
Linseed meal flax, expeller	90.0	32.0	3.5	9.5	0.40	0.80	-	0.11	-	1.24	0.39	700	1540	6.44	0.5	672
Linseed meal flax, solvent	88.0	33.0	0.5	9.5	0.35	0.75	-	0.14	-	1.38	0.39	635	1400	5.86	0.1	1760
Meat and bone meal, 50%	93.0	50.0	8.5	2.8	9.20	4.70	4.70	0.80	0.75	1.40	0.40	1150	2530	10.59	0.5	2000
Millet, pearl grain	90.0	12.0	4.2	1.8	0.05	0.30	0.10	0.04	0.64	0.43	0.13	1470	3240	13.56	1.3	789
Mono-dicalcium phosphate (21% P)	99.0	-	-	-	16.00	21.00	-	0.05	-	0.06	-	-	-	-	-	-
Oats, grain	90.0	11.0	4.0	10.5	0.10	0.35	0.14	0.07	0.12	0.37	0.21	1160	2550	10.67	2.4	1070
Peanut meal, solvent	90.0	47.0	2.5	8.4	0.08	0.57	0.18	0.07	0.03	1.22	0.30	1217	2677	11.20	0.5	1948
Poultry byproduct meal (feed grade)	94.0	57.0	14.0	2.5	5.00	2.70	2.70	0.30	0.55	0.60	0.50	1406	3100	12.97	0.7	5980
Rice bran, unextracted	91.0	13.5	5.9	13.0	0.10	1.70	0.24	0.10	0.07	1.35	0.18	925	2040	8.54	5.2	1948
Rice, grain, rough	89.0	7.3	1.7	10.0	0.04	0.26	0.09	0.04	0.06	0.34	0.10	1335	2940	12.30	0.83	5980
Safflower seed meal, expeller	91.0	20.0	6.6	32.2	0.23	0.61	0.20	0.05	0.16	0.72	0.10	525	1160	4.85	-	800
Salt, NaCl	99.0	-	-	-	-	-	-	39.34	60.66	-	-	-	-	-	-	-
Sodium bicarbonate, NaHCO ₃	99.0	-	-	-	-	-	-	27.38	-	-	-	-	-	-	-	-
Sorghum, milo, grain	89.0	11.0	2.8	2.0	0.04	0.29	0.10	0.03	0.09	0.34	0.09	1505	3310	13.85	1.3	678
Soybeans, full-fat, cooked	90.0	38.0	18.0	5.0	0.25	0.59	0.20	0.04	0.03	1.70	0.30	1520	3350	14.02	9.9	2420
Soybean meal, expeller	89.0	42.0	3.5	6.5	0.20	0.60	0.20	0.04	0.02	1.71	0.33	1100	2420	10.13	1.8	2673
Soybean meal, solvent	90.0	44.0	0.5	7.0	0.25	0.60	0.20	0.04	0.02	1.97	0.43	1020	2240	9.37	0.3	2743
Sunflower meal, expeller	93.0	41.0	7.6	21.0	0.43	1.00	0.25	0.20	0.01	1.00	0.10	1050	2310	9.67	6.5	-
Sunflower meal, partially dehul. solv.	92.0	34.0	0.5	13.0	0.30	1.25	0.27	0.20	0.01	1.60	0.38	1025	2260	9.46	0.2	1909
Triticale	90.0	12.5	1.5	2.59	0.05	0.30	0.10	-	0.07	-	0.20	1430	3150	13.18	0.9	460
Wheat, hard grain	88.0	13.5	1.9	3.0	0.05	0.41	0.12	0.06	0.07	0.50	0.10	1440	3170	13.26	1.00	778
Wheat, soft grain	86.0	10.8	1.7	2.8	0.05	0.30	0.11	0.06	0.07	0.40	0.10	1460	3210	13.43	1.00	778
Wheat bran	89.0	14.8	4.0	10.0	0.14	1.17	0.38	0.06	0.14	1.20	0.22	590	1300	5.44	2.10	980
Wheat middlings	89.0	15.0	3.6	8.5	0.15	1.17	0.45	0.06	0.07	0.60	0.16	950	2090	8.74	1.90	110

Nutrient recommendations are based on calculations using these energy and nutrient values (source: 2018–2019 Feedstuffs Reference Issue and field data). Values provided are “typical” based on ingredient surveys. Nutrient values should be confirmed by analysis of the materials being used in order to maintain an accurate formulation matrix. ¹ For more information, see Feeding Rapeseed Meal or Canola Meal to Hy-Line Brown and Hy-Line Silver Brown Hens.

INGREDIENT (as-fed basis)	CRUDE PRO- TEIN (%)	LYSINE (%)		METHI- ONINE (%)		CYSTINE (%)		THRE- ONINE (%)		TRYPTO- PHAN (%)		ARGI- NINE (%)		ISOLEU- CINE (%)		VALINE (%)	
		Total content	Digestible content	Total content	Digestible content	Total content	Digestible content	Total content	Digestible content	Total content	Digestible content	Total content	Digestible content	Total content	Digestible content	Total content	Digestible content
Barley, grain	11.50	0.53	0.41	0.18	0.14	0.25	0.20	0.36	0.28	0.17	0.12	0.50	0.43	0.42	0.34	0.62	0.50
Beans, broad (vicia faba)	25.70	1.52	1.29	0.25	0.18	0.14	0.09	0.98	0.77	0.24	0.16	2.20	1.91	1.00	0.73	1.22	0.88
Canola meal (38%) ¹	91.0	2.02	1.60	0.77	0.69	0.97	0.71	1.50	1.17	0.46	0.38	2.30	2.07	1.51	1.25	1.94	1.59
Corn, yellow, grain	7.50	0.24	0.19	0.18	0.16	0.18	0.15	0.29	0.24	0.07	0.06	0.40	0.36	0.29	0.26	0.42	0.37
Corn gluten meal (60%)	60.00	1.00	0.88	1.90	1.84	1.10	0.95	2.00	1.84	0.30	0.25	1.90	1.82	2.30	2.19	2.70	2.57
Cottonseed meal (41%), mech. extd	41.00	1.52	0.99	0.55	0.40	0.59	0.44	1.30	0.88	0.50	0.39	4.33	3.81	1.31	0.93	1.84	1.36
Cottonseed meal (41%), direct solv.	41.00	1.70	1.11	0.51	0.37	0.62	0.46	1.31	0.89	0.52	0.41	4.66	4.10	1.33	0.95	1.82	1.34
DL-Methionine	58.10	-	-	99.00	99.00	-	-	-	-	-	-	-	-	-	-	-	-
Fish meal, anchovy, Peruvian	65.00	4.90	4.21	1.90	1.63	0.60	0.43	2.70	2.17	0.75	0.59	3.38	2.77	3.00	2.55	3.40	2.82
Fish meal, white	61.00	4.30	3.70	1.65	1.42	0.75	0.54	2.60	2.09	0.70	0.55	4.20	3.44	3.10	2.64	3.25	2.70
Flaxseed	22.00	0.92	0.79	0.35	0.30	0.42	0.30	0.77	0.62	0.22	0.17	2.05	1.68	0.95	0.81	1.17	0.97
L-Lysine	93.40	78.80	78.80	-	-	-	-	-	-	-	-	-	-	-	-	-	-
L-Threonine	72.40	-	-	-	-	-	-	98.50	98.50	-	-	-	-	-	-	-	-
L-Tryptophan	84.00	-	-	-	-	-	-	-	-	98.00	98.00	-	-	-	-	-	-
Linseed meal flax, expeller	32.00	1.10	0.99	0.47	0.37	0.56	0.44	1.10	1.00	0.47	0.43	2.60	2.39	1.70	1.49	1.50	1.29
Linseed meal flax, solvent	33.00	1.10	0.99	0.48	0.38	0.58	0.45	1.20	1.10	0.48	0.44	2.70	2.48	1.80	1.58	1.60	1.38
Meat and bone meal, 50%	50.00	2.60	2.05	0.67	0.57	0.33	0.19	1.70	1.34	0.26	0.13	3.35	2.85	1.70	1.41	2.25	1.85
Millet, pearl grain	12.00	0.35	0.32	0.28	0.25	0.24	0.20	0.44	0.37	0.20	0.18	0.55	0.49	0.52	0.46	0.70	0.62
Oats, grain	11.00	0.40	0.35	0.20	0.17	0.21	0.18	0.28	0.24	0.18	0.14	0.80	0.75	0.53	0.47	0.62	0.55
Peanut meal, solvent	47.00	1.52	1.29	0.50	0.44	0.60	0.47	1.12	0.91	0.42	0.39	4.76	4.28	1.50	1.32	1.80	1.57
Poultry byproduct meal (feed grade)	57.00	2.25	1.80	0.91	0.78	0.90	0.55	1.88	1.50	0.50	0.26	3.50	3.08	2.10	1.79	2.32	1.93
Rice bran, unextracted	13.50	0.50	0.38	0.17	0.13	0.10	0.07	0.40	0.28	0.10	0.08	0.45	0.39	0.39	0.30	0.60	0.46
Rice, grain, rough	7.30	0.24	0.19	0.14	0.13	0.08	0.07	0.27	0.22	0.12	0.11	0.59	0.54	0.33	0.27	0.46	0.39
Safflower seed meal, expeller	20.00	0.70	0.58	0.40	0.35	0.58	0.45	0.47	0.34	0.30	0.24	1.20	1.01	0.28	0.22	1.00	0.87
Sorghum, milo, grain	11.00	0.27	0.21	0.10	0.09	0.20	0.17	0.27	0.22	0.09	0.08	0.40	0.30	0.60	0.53	0.53	0.46
Soybeans, full-fat, cooked	38.00	2.40	2.16	0.54	0.49	0.55	0.45	1.69	1.43	0.52	0.46	2.80	2.60	2.18	1.94	2.02	1.78
Soybean meal, expeller	42.00	2.70	2.43	0.60	0.54	0.62	0.51	1.70	1.44	0.58	0.52	3.20	2.97	2.80	2.49	2.20	1.94
Soybean meal, solvent	44.00	2.70	2.43	0.65	0.58	0.67	0.55	1.70	1.44	0.60	0.53	3.40	3.16	2.50	2.22	2.40	2.11
Sunflower meal, expeller	41.00	2.00	1.74	1.60	1.47	0.80	0.64	1.60	1.31	0.60	0.52	4.20	3.91	2.40	2.14	2.40	2.08
Sunflower meal, partially dehul. solv.	34.00	1.42	1.19	0.64	0.60	0.55	0.43	1.48	1.26	0.35	0.30	2.80	2.32	1.39	1.25	1.64	1.41
Triticale	12.50	0.39	0.35	0.26	0.23	0.26	0.22	0.36	0.31	0.14	0.12	0.48	0.39	0.76	0.70	0.51	0.44
Wheat, hard grain	13.50	0.40	0.32	0.25	0.22	0.30	0.26	0.35	0.29	0.18	0.16	0.60	0.53	0.69	0.61	0.69	0.59
Wheat, soft grain	10.80	0.30	0.24	0.14	0.12	0.20	0.17	0.28	0.23	0.12	0.11	0.40	0.35	0.43	0.38	0.48	0.41
Wheat bran	14.80	0.60	0.43	0.20	0.15	0.30	0.22	0.48	0.35	0.30	0.24	1.07	0.88	0.60	0.47	0.70	0.54
Wheat Middlings	15.00	0.70	0.56	0.12	0.10	0.19	0.14	0.50	0.36	0.20	0.16	1.00	0.80	0.70	0.58	0.80	0.61

Amino acid digestibility is standardised ileal digestibility. Amino acid values are standardised for 88% dry matter (source: 2018–2019 Feedstuffs Reference Issue and field data). Values provided are “typical” based on ingredient surveys. Nutrient values should be confirmed by analysis of the materials being used in order to maintain an accurate formulation matrix. ¹ For more information, see Feeding Rapeseed Meal or Canola Meal to Hy-Line Brown and Hy-Line Silver Brown Hens.

Disease Control

A flock can only perform up to its genetic potential when disease influence is minimised. The diseases of economic importance vary widely between locations, but in every case, prevention and control is more efficacious than treatment.

Farm Biosecurity

- Biosecurity is the best method of avoiding diseases. A good biosecurity programme identifies and controls the most likely ways that pathogens could enter the farm.
- An all-in/all-out system is the most biosecure, but is not a reality for many commercial poultry farms.
- Ensuring that the house is washed and disinfected before chicks or hens arrive will help the birds to a clean start.
- For more information, see [Pre-Housing Cleaning Checklist](#).
- Downtime between flocks reduces the pathogen load of the facility.



Biosecurity sign

People and Equipment

- All workers and visitors should change into clean farm-specific clothes, hairnet, and footwear.
- Employees should not have contact with other poultry or birds outside of work.
- Showering in and out is optimal.
- Visitor and employee vehicles should park outside the biosecure area.
- Use farm-specific equipment.
- If outside equipment and materials must be brought to the farm, disinfect before contact with birds.

Feed

- Use good quality, tested feed ingredients.
- Store feed ingredients in a clean and secure area.
- Understand that any animal-sourced ingredients (fish meal, meat and bone meal, marine shell) may have a greater risk of *Salmonella* or other contamination..

Dead Bird Disposal

- Quickly and properly dispose of dead chickens daily. Allowing dead birds to remain in the house can increase the risk of disease for the rest of the flock.
- Dispose of dead birds by rendering, incineration, or composting.

Rodents

- Rodents are known carriers of many poultry disease. Rodents, along with insects and humans, are also responsible for facility-to-facility spread of disease on a farm, and a common reason for recontamination of a cleaned and disinfected poultry facility.
- The farm should be free of debris, tall grass and other places that could harbor rodents.
- The perimeter of each facility should have a 1 m wide area of crushed rock or concrete to prevent rodents from burrowing into the facility.
- Feed and eggs should be stored in rodent-proof areas and any spillages cleaned up immediately.

- Bait stations should be placed around the perimeter of the facility as well as throughout the facility and maintained with fresh rodenticide.
- In closed facilities, fill any gaps in the entrances, walls and roof which could provide rodent access into the poultry facility.
- For more information, see **Code of Practice for the Prevention of Rodent Infestation on Poultry Farms**.

Vertically Transmitted Diseases

- The main vertically transmitted diseases of concern for poultry are lymphoid leukosis, *Mycoplasma gallisepticum*, *Mycoplasma synoviae*, *Salmonella Pullorum*, *Salmonella Gallinarum*, *Salmonella Enteritidis*, and *Salmonella Typhimurium*.
- All breeding stock sourced directly from Hy-Line International are free of these diseases.
- Disease-free breeders are the first step in control of these diseases for commercial layers.
- Due to the possibility of horizontal transmission of these diseases, later generations may not remain free.
- It is responsibility of breeding and commercial flock owners to prevent horizontal transmission of these diseases and continue testing to be assured of a negative status.

Vaccination Programming

For information on vaccination programmes, see **Vaccination Recommendations**.

Internal Parasites

Internal parasites can be a significant problem for free-range flocks by causing damage to the bird's intestinal tract and reducing the absorption of feed nutrients.

Signs of internal parasites:

- Loss of shell strength, yolk, colour, and egg size.
- Poor body weight gain leading to unevenness or stunted birds. Affected birds may be dull and show pale combs.
- Increased cannibalism through vent pecking due to straining.
- Death in very heavy infestations.
- Internal parasites can make birds more susceptible to disease or worsen an existing disease condition.
- Worm populations can increase rapidly in the flock. Consult with a veterinarian for an appropriate parasite control programme. (Check local regulations regarding treatment and prevention options for internal parasites.)



Ascarids (roundworms) is a common parasite of barn-reared and free range birds. Light infestations can rapidly become heavy infestations.
Photo: Dr. Yuko Sato, Iowa State University.

Capillaria Spp. (hairworms or threadworms)

- These are much smaller (hair-like) and are barely visible with the naked eye but can cause significant damage even in only moderate infestations.
- *Capillaria* worms can infest the crop, esophagus, and intestine.
- Eggs become infective in 4–6 weeks in faeces.
- Some species of *Capillaria* use the earthworm as an intermediate host to complete its life cycle.

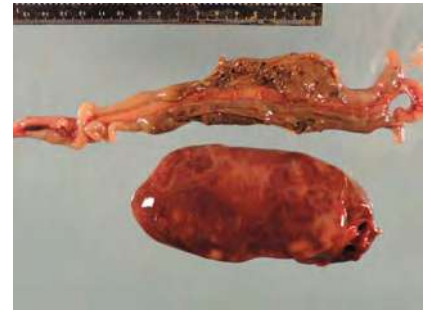

Caecal worms (*Heterakis*) can carry the protozoa (*Histomonas meleagridis*) responsible for the disease called Blackhead. Photo: Dr. Yuko Sato, Iowa State University

Heterakis gallinarum (caecal worms)

- *Heterakis* worms spend most of their time in the ceca, located at the lower end of the intestine. They cause no obvious harm in themselves, but can carry another parasite called *Histomonas meleagridis*, the cause of Blackhead.
- Effective control of caecal worms provides good protection against Blackhead. *Heterakis* eggs can survive three years in pastures.
- Birds become infected by picking up worm eggs from litter, soil, and faeces.
- The worm eggs need warm, moist conditions to develop outside the bird, which is why problems are frequently worse in the spring and summer, especially following a wet spring.



Heavy infestation of tapeworms within the intestine. Tapeworms compete with the bird for available nutrients.

Cestodes (tapeworms)

- Flat, ribbon-shaped, segmented intestinal worms that anchor their heads (scolex) into the wall of the bird's small intestine with hook-like mouthparts. Despite this, most tapeworms do not cause physical damage to the intestinal wall.
- Tapeworms compete for available nutrients in the intestinal tract of birds, damaging their health and hampering growth.
- *Davainea proglottina* is a species of tapeworm which can cause damage to the intestinal tract. If the worms migrate to the head and sinuses, the birds may present with neurological signs such as torticollis.
- Birds become infected with tapeworm by eating intermediate hosts, which include arthropods and other invertebrates. Controlling these intermediate hosts and good pasture management will help reduce the infectious pressure. See **Fly Management**.
- Drug treatments are available, but most are used off label, thus requiring the advice of a veterinarian.

Control of internal parasites:

- Worm infestation in the flock is identified by microscopic examination of faeces to look for parasite eggs.
- Internal parasite infestations should be routinely monitored by necropsy of cull birds and microscopic examination of faeces for worm egg counts.
- Effective control is aimed at breaking the cycle of infection.
- Strategic use of feed or water-administered deworming treatments will control worms in the flock. Start treatments in the rearing phase and continue through the laying period.

Protozoa

Coccidia infection may lead to intestinal damage and, in severe infestations, death. More commonly, poor control of sub-clinical infection reduces feed conversion or leaves pullets with chronic, irreversible gut damage. Pullet flocks may be uneven or underweight at housing and not perform to their full potential in lay.



Cecal coccidiosis (*Eimeria tenella*).

Control of coccidia includes the following measures (check local regulations):

- Use ionophores or other chemicals in a step-down dosing programme to protect the bird from coccidiosis and allow stimulation of immunity in pullets.
- Cocci vaccines require cycling by contact to manure to achieve full immunity. Discuss this with the vaccine manufacturer.
- Live vaccine use is preferred to anti-coccidial drug treatments. Vaccines are administered in the hatchery as a spray or spray gel, or at chick placement in the rearing facility.
- Control of flies and beetles, which are vectors of coccidia spread.
- Cleaning and disinfection of facilities reduces challenge pressure. The oocysts are resistant to disinfection and can persist in the environment.

External Parasites

Red Mite (*Dermanyssus gallinae*)

Red mite is an important external parasite in laying flocks in all systems of management. Red mites are nocturnal blood feeders that hide during the day in dark, secluded areas in the facility. Red mites multiply rapidly in warm summer months. Even light infestations create irritation, leading to poor performance and feed intake.



Red mite (*Dermanyssus gallinae*).



Red mites come out from hiding locations at night to take a blood meal from birds.

Signs of red mite infestation in the flock:

- Flocks that are nervous with increased feather and vent pecking behaviour.
- Feed intake may be depressed.
- Reduction in egg production by up to 5%.
- Birds become anaemic due to blood loss. These birds will be evident in the flock by their pale combs. If severely affected, mortality may increase.
- Loss of shell or yolk colour.
- Soiling of eggshells with mite faeces, which may lead to downgrading of eggs.
- Egg collectors may experience skin irritation from red mites.

Controlling Red Mite:

- Breaking the cycle of re-infection when the facility is empty is the most effective approach.
- Treat the facility between flocks, immediately after the birds are removed from the facility while the red mites are still active.
- Use approved and effective products that have been properly applied, to reach into all crevices on equipment, walls, slats, and nest boxes.
- Use a fan nozzle to produce a flat spray for good coverage of surfaces and crevices.
- Do not mix pesticides with disinfectants, unless recommended by the manufacturer.
- Red mites can live off the bird without feeding for up to 6 months. Facilities typically require multiple treatments to eliminate infestation. Filling cracks or holes in the facility and equipment will limit potential red mite areas in the facility.
- Apply treatments at night when red mites are active.
- Rotate pesticide products to avoid mites developing resistance.
- Monitor the facility and birds during the life of the flock and provide prompt treatment when red mites are observed.
- Schedule treatments to break the red mite life cycle, which is 10 days. A three-treatment program (on days 0, 10 and 20) is effective.

Red mite/northern fowl mite treatments (check local regulations regarding mite treatment):

- **Pyrethroids**—A manmade chemical that causes paralysis and death in insects. As this is a common treatment, resistant varieties of mites exist throughout the world.
- **Organophosphates, carbamates**—Interferes with acetylcholine transmission in insects which causes death of the mite. Normally ingested by the parasite, there are types ingested by the birds that are passed to the mite when birds are bitten.
- **Fluralaner**—Acts as a potent inhibitor of the mite's nervous system by acting antagonistically on ligand-gated chloride channels (GABA-receptor and glutamate-receptor).
- **Vegetable oil**—Apply directly to the chicken to treat mites (impractical solution for large operations).
- **Mineral-based products (both liquid and sand dusts)**—Can be applied to the floor and walls of the facility to prevent the spread of mites.
- **Diatomaceous earth products**—These kill mites by absorbing the lipids from the exoskeleton and causing dehydration. Unlike pesticides, there is no development of resistance with these products.

Northern Fowl Mite (*Ornithonyssus sylviarum*)

Northern fowl mite is another common ectoparasite of chickens. These mites feed on blood and skin cells of the chicken and can cause significant losses of productivity and health with heavy infestations. Northern fowl mite is usually found on the downy feathers that surround the cloaca (vent). They live on the bird for their entire life but can survive off the bird for up to three weeks. Mites can be found on eggs, egg belts, and on poultry workers when infestations are severe. There can be increased susceptibility of some individual birds to infestations while other birds are unaffected. Infested birds can be identified by finding characteristic dark areas on the feathers around the vent made up of mites, dead mites, dried blood and skin cells.

Signs of northern fowl mite infestation in the flock:

- Flocks that are nervous with increased feather and vent pecking behaviour.
- Feed intake may be depressed.
- Reduction in egg production by up to 5%.
- Birds become anaemic due to blood loss. These birds will be evident in the flock by their pale combs. If severely affected, mortality may increase.
- Loss of shell or yolk colour.
- Increase soiling of eggshells with mite faeces which may lead to downgrading of eggs.
- Egg collectors may experience skin irritation from northern fowl mites.



Northern fowl mites live on the feathers surrounding the vent area and feed on blood and skin cells, causing irritation and loss of productivity. Photo: Dr. Bradley Mullens, University of California, Riverside.



Mites can be found on eggs and egg belts. Photo: Dr. Bradley Mullens, University of California, Riverside.

Controlling northern fowl mite (check local regulations regarding mite treatment):

- Life cycle is 4–5 days, so outbreaks can occur rapidly.
- Pesticide treatments do not kill eggs, so repeat treatments are needed for good control.
- Sulphur treatment of the environment or feed has been reported to have a good effect on controlling northern fowl mites.
- The pesticide must penetrate the feathers to be effective. Sprays should be delivered at 125 PSI and be directed to the vent area. Dust baths utilising powder containing insecticide can be used in alternative systems.
- Individual birds can be dipped into room temperature pesticide solutions.
- A small stock oral dosing gun can be used to apply pesticide through the feathers directly onto the skin of the bird.

Bacterial Infections

Brachyspira (spirochaetes)

- *Brachyspira pilosicoli* is an intestinal spirochaete associated with inflammation of the large intestine in a broad range of mammals and birds.
- It has been associated with typhilitis (inflamed ceca), diarrhea (yellow and frothy), reduced egg production, and egg shell soiling in chickens.
- Other related organisms can be present without causing adverse effects (*Brachyspira innocens*) or varying severity of adverse effects (*Brachyspira intermedia* and occasionally *Brachyspira hyodysenteriae*, the cause of swine dysentery).
- An abundance of frothy yellowish faeces is often considered to be an indication of *Brachyspira* infection.
- Laboratory diagnosis of infection is based on culture or PCR of pooled faecal samples. Microscopic examination of pooled faecal samples is another method of identification.
- Affected flocks can be given antibiotic treatment (check local regulations concerning antibiotic use).

Mycoplasma gallisepticum

- See **[MG Control in Commercial Layers.](#)**

Mycoplasma synoviae

- See **[Mycoplasma Synoviae.](#)**

Focal Duodenal Necrosis (FDN)

- See **[An Overview of Focal Duodenal Necrosis.](#)**

Colibacillosis

- See **[Colibacillosis in Layers: An Overview.](#)**

Flock Monitoring

Body Weight Measurements

0–3 Weeks: Bulk weigh 10 boxes of 10 chicks.

4–29 Weeks: Weigh 100 birds individually every week; calculate uniformity.

30–90 Weeks: Weigh 100 birds individually every 5 weeks; calculate uniformity.

When handling birds for body weights, assess:

- Keel bone—straightness and firmness (see [Understanding the Role of the Skeleton in Egg Production](#))
- Body score (see Body Score Chart)
- Body fat
- External parasites
- Clinical symptoms of disease

Sera Collection

- Collect 10–20 sera samples per flock for titer determination.
- For more information, see [Proper Collection and Handling of Diagnostic Samples](#).

8 Weeks: Assess early vaccination technique and disease exposure.

15 Weeks: Collect sera before transfer to lay facility to assess possible change in disease exposure. It is common to not send to laboratory and freeze for future analysis in event of disease outbreak on lay farm.

16–24 Weeks: Collect sera at least 4 weeks after final inactivated vaccination to measure post-vaccination antibody response. It is useful to assess disease challenge and response to inactivated vaccinations after transfer to lay farm.

Monitor Egg Weights

Weigh 100 eggs from randomly selected nests. Monitor egg weights on a specific day of the week within the same 3-hour time frame. Monitor worm egg counts in pooled faecal samples every month.

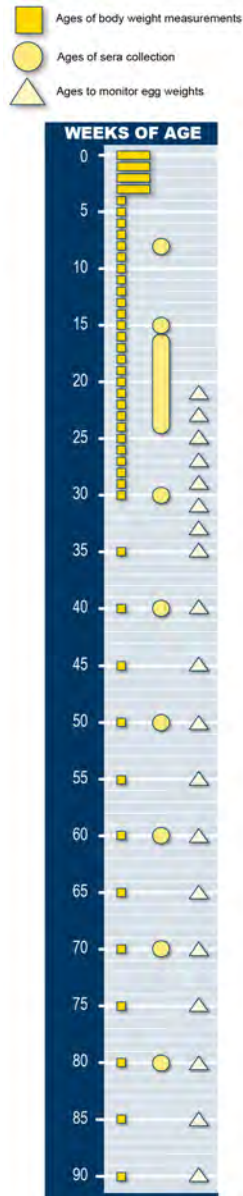

Always consult hyline.com for the latest performance, nutrition, and management information.

RESOURCES AVAILABLE AT WWW.HYLINE.COM

[Corporate Information](#) | [Technical Updates](#) | [Videos](#) | [Interactive Management Guides](#)
[Hy-Line International Lighting Programme](#) | [Hy-Line EggCel](#) | [Body Weight Uniformity Calculator](#)

TECHNICAL UPDATES

Diseases

An Overview of Focal Duodenal Necrosis (FDN)

MG Control in Commercial Layers

Colibacillosis in Layers: An Overview

Fowl Pox in Layers

Avian Urolithiasis (Visceral Gout)

Infectious Bursal Disease (IBD, Gumboro)

Fatty Liver Hemorrhagic Syndrome

Infectious Laryngotracheitis (ILT)

Intestinal Dilation Syndrome (IDS)

Newcastle Disease

Mycoplasma Synoviae (MS)

Low Pathogenic Avian Influenza (LPAI)

Diagnostic Samples and Breeder Flock Monitoring

Salmonella, *Mycoplasma*, and Avian Influenza Monitoring in Parent Breeder Flocks

Proper Collection and Handling of Diagnostic Samples

Management

Growing Management of Commercial Pullets

Understanding the Role of the Skeleton in Egg Production

The Science of Egg Quality

Understanding Poultry Lighting

Understanding Heat Stress in Layers

Infrared Beak Treatment

Feed Granulometry and the Importance of Feed Particle Size in Layers

Impact of Tarp Colour on Poultry Lighting

SPIDES (Short Period Incubation During Egg Storage)

Fly Management: Surveillance and Control

Optimising Egg Size in Commercial Layers

Vaccination Recommendations

Egg Drop Syndrome (EDS)

Managing Fully Beaked Flocks

Thiamin Deficiency in Pullets

Understanding Nesting Behaviour

PRODUCT UPDATES

Hy-Line Brown – Selecting for Superior Egg Quality

Feeding Rapeseed Meal or Canola Meal to Hy-Line Brown and Hy-Line Silver Brown Hens

Hy-Line International | www.hyline.com

Hy-Line is a brand name. ® Registered trademark of Hy-Line International.

© Copyright 2021 Hy-Line International.

BRN COM ENG 112922

